

# Nicaragua Manual Block Press

Kathryn Rose and John McGarry

## Problem

Rama Cay, a small island in Nicaragua, is vastly over-populated with poor living conditions. Inhabitants have asked Friends in Action (FIA) for help moving inland, which requires the construction of affordable houses. Nicaragua has abundant clay, which can be used to create compressed earth blocks. FIA has requested a simple and affordable block press that can allow the Rama people to create their own blocks in order to build new homes for their families.



## Design

- The press was based on the CinvaRam design.
- The design was modified to meet FIA specifications.
- Modifications include holes for rebar and interlocking ridges

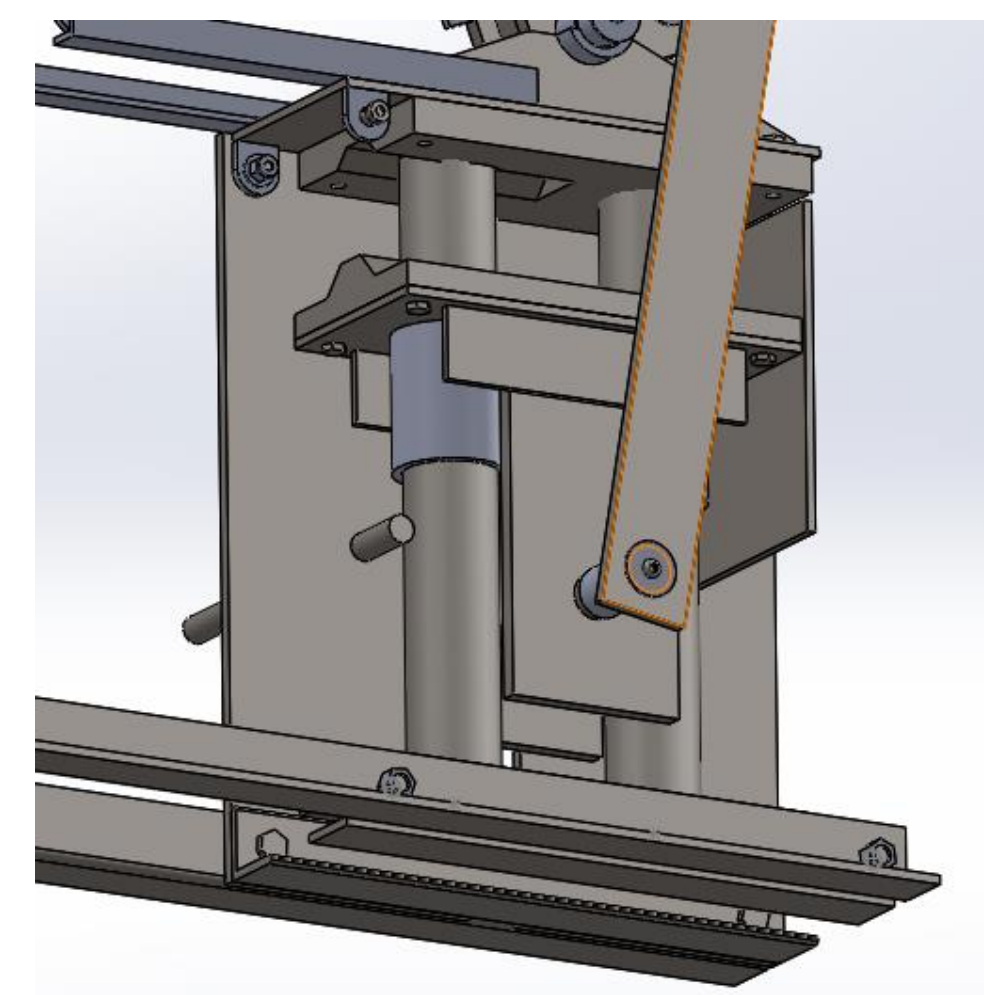

Specifications
Operable by 2–3 people
Mobile
Reproducible for FIA
Durable
Minimum output of 200 blocks per day



## Fabrication

The press is being manufactured in Lebanon, PA by E&E Metal Fab., Inc.



## Acknowledgements

- Tim Johnston, Friends in Action International
- Willie Erb, CEO of E&E
- Adam Janney, CAD Designer/ME for E&E
- Philip Tan, Project Manager
- Josh Charney, Student Project Manager
- John Meyer, Shop Manager

## Mixing

The bricks are made of a hand-mixed composition of cement, clay, sand, and water.



## Loading

The brick mixture is poured into the press chamber up to the fill line.



## Pressing

The mixture is then fully compacted by pushing the lever arm into a forward position.



## Ejecting

The lid is then removed and the block is ejected by pushing the lever arm over a fulcrum.



## Curing

The formed brick is then laid out to dry for about a week.



## Water Absorption Testing

Due to the climate of this region, the blocks will have to maintain their function when wet for long periods of time. To test for water resistance, cured blocks were submerged for 24 hours to test how much water they would absorb.



## Compression Testing

Cured bricks are tested for strength in compression in order to assure that they will be able to withstand a reasonable load. So far, our bricks have withstood over 2000 psi.



## Project Goals

The end goal of this project is to create a simple design for a compressed earth block press. The designs will be put into a user manual which will contain the manufacturing drawings so that multiple presses can be built as the need arises. The manual will also include mixing and loading instructions and other operational details for the press. We will then give the manual to Friends in Action so that they can take this design and help as many people as they can build their own housing.



## Moving Forward

This semester, the team is finalizing the manufacturing drawings and testing the new press. Next semester, we will evaluate the results of the completed compression and water absorption tests and determine the optimal mixture for use in the press. Finally, the team will prepare the user manual before giving the press to Friends in Action.