



**MESSIAH UNIVERSITY**

ONE UNIVERSITY AVENUE, MECHANICSBURG, PENNSYLVANIA 17055  
UPPER ALLEN TOWNSHIP, CUMBERLAND COUNTY

**PROJECT MANUAL**  
**TECHNICAL SPECIFICATIONS TABLE OF CONTENTS PART 1**  
**Section 020000 to 140010**

**Section 020000      Administrative**

Section 020010      Background Checks ..... Page 1  
Section 020020      Pre-bid Meeting ..... Pages 1 – 2  
Section 020100      Insurance Requirements.....Page 1  
Section 020200      Protection of Persons and Property.....Pages 1-2  
Section 020210      Miscellaneous Provisions.....Pages 1-3  
Section 020300      Code Required Special Inspections and Procedures.....Pages 1-3

**Section 040000      General**

Section 040010      Cutting and Patching..... Pages 1 – 4  
Section 040020      Construction Waste and Disposal ..... Page 1

**Section 060000      Temporary During Construction**

Section 060010      Temporary Facilities and Controls..... Pages 1 – 10  
Section 060020      Temporary Tree and Plant Protection ..... Pages 1 – 7

**Section 080000      Roof**

Section 080010      Ethylene Propylene Diene Monomer (EPDM) Roofing ..... Pages 1 – 11  
Section 080020      Roof Specialties ..... Pages 1 – 9  
Section 080030      Rood Accessories..... Pages 1 – 9

**Section 100000      Doors**

Section 100010      Hollow Metal Doors and Frames ..... Pages 1 – 10  
Section 100030      Doors and Frames ..... Pages 1 – 49  
Section 100040      Access Doors and Frames ..... Pages 1 – 4  
Section 100050      Door Window Light Kits ..... Page 1  
Section 100060      Sectional Doors..... Pages 1 – 5  
Section 100070      Aluminum Framed Entrances and Storefronts..... Pages 1 – 14  
Section 100080      Fire Rated Entrances and Storefronts..... Pages 1 – 11

**PROJECT MANUAL**  
**TECHNICAL SPECIFICATIONS TABLE OF CONTENTS PART 2**

**Section 100000      Doors (Continued)**

Section 100081	Automatic Entrances.....	Pages 1 - 8
Section 101000	Door Hardware.....	Pages 1 - 14

**Section 120000      Plumbing**

Section 120010	General Provisions- Plumbing .....	Pages 1 - 13
Section 120020	Plumbing Basic Materials .....	Pages 1 - 6
Section 120030	Plumbing Pipe and Pipe Fittings.....	Pages 1 - 8
Section 120040	Plumbing Piping Specialties .....	Pages 1 - 4
Section 120050	Plumbing Specialties.....	Pages 1 - 4
Section 120060	Plumbing Valves .....	Pages 1 - 4
Section 120070	Plumbing Supports and Anchors .....	Pages 1 - 4
Section 120080	Plumbing Insulation .....	Pages 1 - 4
Section 120110	Plumbing Pumps .....	Pages 1 - 2
Section 120120	Sanitary Drainage.....	Pages 1 - 5
Section 120130	Interceptors.....	Pages 1 - 2
Section 120140	Storm Drainage .....	Pages 1 - 3
Section 120150	Water Conditioning System .....	Pages 1 - 2
Section 120160	Water Heater .....	Pages 1 - 2
Section 120170	Plumbing Fixtures.....	Pages 1 - 8
Section 120180	Special Piping Systems .....	Pages 1 - 4
Section 120190	Fuel Gas Piping and Specialties.....	Pages 1 - 2
Section 120200	Wiring of Plumbing Equipment.....	Pages 1 - 2
Section 120210	Emergency Shower and Eye Wash .....	Pages 1 - 4
Section 120220	Plumbing Specs.....	Pages 1 - 65
Section 120230	Plumbing Specs (2).....	Pages 1 - 8
Section 120240	Disinfection of Water Lines .....	Pages 1 - 3
Section 120250	Pipe Leak Testing.....	Pages 1 - 8
Section 120260	Exterior Hose Bib .....	Pages 1 - 6
Section 120270	Lab Faucets.....	Page 1
Section 120280	Eye Wash.....	Page 1
Section 120290	Water Cooler.....	Pages 1 - 3

**Section 140000      Water Treatment**

Section 140010	Chemical Water Treatment.....	Pages 1 - 2
----------------	-------------------------------	-------------

## **SECTION 020010**

### **PART 1 – BACKGROUND CHECKS**

#### **1.1 BACKGROUND CHECKS**

- A. Contractors must comply with Messiah University’s background check policy, found on the purchasing website.

**\*\*END OF SECTION\*\***

**SECTION 020020  
PREBID MEETING**

1.1 PREBID MEETING

- A. Owner will conduct a Pre-bid meeting as indicated below:
  - 1. Meeting Date:
  - 2. Meeting Time:
  - 3. Location:
  
- B. Attendance:
  - 1. Prime Bidders: Attendance at Pre-bid meeting is **mandatory**.
  - 2. Subcontractors: Attendance at Pre-bid meeting is recommended.
  - 3. Notice: Bids will only be accepted from prime bidders represented on Pre-bid Meeting sign-in sheet.
  
- C. Bidder Questions: Submit written questions to be addressed at Pre-bid meeting minimum of **two** business days prior to meeting.
  
- D. Agenda: Pre-bid meeting agenda will include review of topics that may affect proper preparation and submittal of bids, including the following:
  - 1. Procurement and Contracting Requirements:
    - a. Instructions to Bidders.
    - b. Bonding.
    - c. Insurance.
    - d. Bid Form and Attachments.
    - e. Bid Submittal Requirements.
    - f. Bid Submittal Checklist.
    - g. Notice of Award.
  
  - 2. Communication during Bidding Period:
    - a. Obtaining documents.
    - b. Bidder's Requests for Interpretation.
    - c. Bidder's Substitution Request / Prior Approval Request.
    - d. Addenda.
  
  - 3. Contracting Requirements:
    - a. Agreement.
    - b. The General Conditions.
    - c. Other Owner requirements.
  
  - 4. Construction Documents:
    - a. Scopes of Work.

- b. Temporary Facilities.
  - c. Use of Site.
  - d. Work Restrictions.
  - e. Alternates, Allowances, and Unit Prices.
  - f. Substitutions following award.
5. Separate Contracts:
- a. Work by Owner.
  - b. Work of Other Contracts.
  - c. Contractor installation of Owner provided items.
6. Schedule:
- a. Project Schedule.
  - b. Contract Time.
  - c. Liquidated Damages.
  - d. Other Bidder Questions.
7. Site / facility visit or walkthrough.
8. Post-Meeting Addendum.
- E. Minutes: The Owner will address pre-bid meeting questions by Addendum as required. Meeting minutes may or may not be issued by the Owner. Minutes of meeting are issued as Available Information and do not constitute a modification to the Procurement and Contracting Documents. Modifications to the Procurement and Contracting Documents are issued by written Addendum only.
1. Sign-in Sheet: Minutes may include list of meeting attendees.

\*\* END OF SECTION \*\*

**SECTION 020100**  
**INSURANCE REQUIREMENTS-CONSTRUCTION**

Liability Limits: The insurance required by Messiah University for the Ravine Stabilization Project shall be written for not less than the following limits unless the limit provided herein is less than that required by applicable law, in which case the greater limit shall apply. All limits under the General Liability coverage shall apply on a per project basis:

Workers' Compensation:

- a. State: statutory requirement
- b. Federal: statutory

Comprehensive Contractors' General Liability

- a. Bodily Injury and Property Damage:
  - \$1,000,000 per occurrence
  - \$3,000,000 aggregate
- b. Products Completed Operations:
  - \$3,000,000 aggregate
- c. Contractually Assumed Liability for Bodily Injury and Property Damage:
  - \$1,000,000 per occurrence
  - \$3,000,000 aggregate
  - Liability coverage shall be written under an occurrence policy with all limits applying on a project basis.
- d. Personal Injury:
  - \$3,000,000 aggregate

Automobile Liability:

- a. Bodily Injury:
  - \$1,000,000 per person
  - \$1,000,000 per accident
- b. Property Damage:
  - \$1,000,000 per accident

Additional Insured: The University, the Architect and their consultants shall be named as additional insureds under the policies of insurance required under the above paragraphs.

Coverage: All coverage required shall be on an "occurrence" rather than a "claims made" basis.

**SECTION 020200  
PROTECTION OF PERSONS AND PROPERTY**

**PART 1 - GENERAL**

**1.1 SAFETY PRECAUTIONS AND PROGRAMS**

- A. Contractor shall notify the Owner prior to renovation operations in which more than 260 linear feet or 160 square feet regulated asbestos-containing material is stripped or removed from facility components.
- B. In lieu of any existing products known to contain hazardous materials (asbestos, lead paint, etc.) and are scheduled to be removed, should any Contractor encounter asbestos, lead paint, hazardous materials or suspect the presence of such in a material, he shall immediately stop work and notify the Owner who shall then take action for its removal.
- C. The Owner and Owner's Representative make no representation regarding the possible presence of hazardous materials, including but not limited to asbestos, polychlorinated biphenyl (PCB) and lead based paints within the area of construction. It is the Contractor's sole responsibility to implement any and all necessary test procedures and precautions against such possibility and to strictly follow and enforce all municipal, state, and federal regulations regarding any hazardous material and safe work place practices and hazardous material disposal.
- D. If the Contractor fails to give such notices, or fails to comply with such laws, ordinances, rules, regulations, and lawful orders, it shall be liable for and shall indemnify and hold harmless the Owner and their respective employees, officers, and agents, against any resulting fines, penalties, judgements, or damages, including reasonable attorney's fees, imposed on or incurred by the parties indemnified hereunder.

**1.2 SAFETY OF PERSONS AND PROPERTY**

- A. The Contractor shall provide and maintain in good operating condition suitable and adequate fire protection equipment and services, and shall comply with all reasonable recommendations of the fire insurance company carrying insurance on the Work or by the local fire chief or fire marshal. The area within the sire limits shall be kept orderly and clean and all combustible rubbish shall be promptly removed from the site.
- B. The Contractor shall at all times protect excavations, trenches, buildings and materials from rainwater, ground water, back up or leakage of sewers, drainage or other piping, and from water of any other origin and shall remove promptly any accumulation of water. Contractor shall provide and operate all pumps, piping and other equipment necessary to this end.
- C. The contractor shall remove snow or ice which may result in damage or delay.
- D. The Contractor shall take all precautions necessary to prevent loss or damage caused by vandalism, theft, burglary, pilferage, or unexplained disappearance of property of the Owner, whether forming part of the Work, located within those areas of the Project to which the Contractor has access. The Contractor shall have full responsibility for the security for such

property of the Owner located in such areas and shall reimburse the owner for any such loss, damage or injury, except such as may be directly caused by agents or employees of the Owner.

### 1.3 DEMOLITION AND RENOVATION OPERATIONS

- A. To protect persons and property, the Contractor shall take all necessary precautions during demolition and renovation operations to locate and discontinue or otherwise identify and protect existing utilities; to maintain the structural integrity of the building, and to protect the interior contents of the building during construction operations.
- B. All demolition work shall be done by qualified tradesmen from each respective trade, especially in the areas of structural, mechanical, and electrical demolition.
- C. Upon request, the Owner and the Contractor shall attend a meeting to review the facility operations and performance.

\*\* END OF SECTION \*\*



**SECTION 020210  
MISCELLANEOUS PROVISIONS**

**PART 1 - GENERAL**

**1.1 TESTS AND INSPECTIONS**

- A. This paragraph governs testing and inspection required by the Drawings and Specifications to be performed by Contractor. Owner will arrange for an independent testing and inspection firm to perform those tests and inspections not required to be performed by Contractor or its Subcontractor.

**1.2 CODE COMPLIANCE**

- A. Fire Rated Assemblies: All penetrations and openings whether indicated or not through fire-rated walls, floor/ceiling or roof/ceiling assemblies which are indicated on the drawings, shall be provided and installed to maintain the fire-rated integrity of the design with dampers, tenting over lights, etc. These penetrations and openings include, but shall not be limited to, louvers, lights, mechanical and electrical penetrations, etc.
- B. Fire Rated Partitions: All fire partitions shall extend from the top of the floor assembly below to the underside of the floor/roof slab or deck above, to the fire resistance rated floor/ceiling or roof/ceiling assembly above, and shall be securely attached thereto.

**1.3 WORK RESTRICTIONS**

- A. On Site Work Hours: Work shall be generally performed inside the existing building during normal business hours of between 7:30 AM to 4:00 PM, Monday through Friday, except otherwise indicated.
  - 1. Weekend hours: Coordinate with Owner
  - 2. Early morning hours: Coordinate with Owner
  - 3. Hours for utility shutdowns: Coordinate with Owner
  - 4. Hours for core drilling: Coordinate with Owner
- B. Existing Utility Interruptions: Do not interrupt utilities serving facilities occupied by Owner or others unless permitted under the following conditions and then only after arranging to provide temporary utility services according to requirements indicated:
  - 1. Notify Owner not less than 3 days in advance of proposed utility interruptions.
  - 2. Do not proceed with utility interruptions without Owner's written permission.
- C. Nonsmoking Campus: Smoking is not permitted on Campus.

**1.4 MISCELLANEOUS PROVISIONS**

- A. Existing Utilities: The Contractor shall call 811 'One Call System' as indicated prior to performing any excavation work.

1. Locate existing underground utilities in areas of excavation work prior to beginning excavation operations. Visibly mark or stake existing utilities for the duration of construction and renovations. If utilities are indicated to remain in place, provide adequate means of support and protection during earthwork operations.
  2. Should uncharted, or incorrectly charted piping or other utilities be encountered during excavation, consult utility owner immediately for directions. Cooperate with Owner and utility companies in keeping respective services and facilities in operation. Repair damaged utilities to satisfaction of utility owner.
  3. Do not interrupt existing utilities serving facilities occupied by Owner or others, during occupied hours, except when permitted in writing by Owner and then only after acceptable temporary utility services have been provided.
  4. Provide minimum 48-hour notice to Owner and receive written notice to proceed before interrupting any utility.
- B. Compliance with Pennsylvania Acts 287 and 222: Contractors shall call 811 (One Call System) to verify the exact location of underground facilities within not less than three (3) nor more than ten (10) working days prior to beginning any excavation or demolition work as required by General Assembly of the Commonwealth of Pennsylvania Act 172 (HB 1735).
- C. Criminal History Information: Pursuant to Section 111 of the Public School Code of 1949, Act of March 10, 1959, P. L. 30, No. 14, as amended, H. B. 1139, Session of 1985, 24 P. S. #111, prospective employees of public and private schools, intermediate units and area vocational technical schools, including independent contractors and their employees, except employees and independent contractors and their employees who have no direct contact with children, are required, prior to employment, to furnish certain information, as set forth on this form.
1. The successful vendor must submit, on prescribed form, a report of criminal history information from the Pennsylvania State Police or a statement from the State Police that the State Police central repository contains no such information relation to him/her and any employee working on the school district's site. The report or statement must be no more than one year old. To obtain this document, contact the State Police Barracks nearest your home. You must submit the original of the required document if awarded the bid before commencing with the project(s).
  2. For the Prime Contractors, or any of their employees, whether residents of Pennsylvania or not, reports on the Federal Criminal History from the Federal Bureau of Investigation must be submitted. The report must be not more than one year old. To obtain such a report, contact the FBI Field Office nearest you.
  3. If the decision not to award this bid to you is based in whole or in part on your criminal history record information you will be so notified in writing.
  4. Criminal History Record Information sheets must be submitted with Performance and Payment bonds.
- D. Use of Tobacco Products: In accord with the University Policies- smoking and other use of tobacco is prohibited on Campus. Contractors and their employees working on Owner's property are similarly prohibited from smoking in Owner's buildings, or on Owner's property.
- E. Safety: Contractor is responsible for initiating, maintaining, and supervising all safety precautions and programs in connection with the Work.
1. Contractor shall take all reasonable precautions for the safety of, and shall provide all reasonable protection to prevent damage, injury, or loss to all employees on the Work and all other persons who may be affected thereby.

2. Contractor shall give all notices and comply with all applicable laws, ordinances, rules, regulations, codes of standards bearing on the safety of persons or their protection from damage, injury or loss, including without limitation, compliance with the requirements of the Occupational Safety and Health Act (OSHA) as amended from time to time. Nothing in this agreement or any other company directive or document relieves the Contractor from fully understanding and complying with the foregoing. Contractor shall develop and implement a safety program responsive to the standards of OSHA, communicate such safety program to its employees, and Contractor will strictly enforce the safety rules under such safety program.
  3. Barricades and Guard Lights: Provide and maintain barricades, railings, and guard lights at obstructions, trenches, excavations, newly laid concrete, etc., wherever necessary to safeguard public and in accordance with applicable codes and ordinances.
- F. Americans with Disabilities Act (ADA): Whether indicated or not, the Contractor must comply with Americans with Disabilities Act Guidelines (ADAG) and ANSI 117.1-1986, including but not limited to mounting heights of all equipment, fixtures, accessories, clearances, hardware, railings, signage, slip resistance of floors and ramps, etc.
- G. Protection Requirements:
1. Bracing, Shoring, and Sheeting: Provide shoring, bracing, and sheeting required to safely execute work under contract and remove it after it has served its purpose.
  2. Loss by Theft or other Causes: Contractor shall protect against loss of material, work, or equipment by theft, vandalism or other causes and take such precautions as he sees fit to protect himself against loss therefrom. To safeguard building and contents, stored materials, and equipment may necessitate watchman's service and Contractor shall bear the cost for such service.
  3. Weather Protection: Provide adequate protection of work and materials against damage by elements, rain, snow, wind, storms, frost, or heat. At end of day's work, protect new work liable to damage with temporary covering.
  4. Fire Protection: Take reasonable precaution to guard against damage by fire and provide suitable fire protection equipment as deemed necessary. Do not build fire on premises.
  5. Site Protection: Protect roads, curbs, sidewalks, and landscape work from damage, providing guards and covering, whether on site, on adjacent properties, or on public streets. Repair or replace damaged work at Contractor's expense.
  6. Adjoining Property: Take adequate precautions and provide safeguards to protect adjoining property, buildings, fences, etc., against damage from blasting, excavating, moving equipment or other operations under this control.

\*\* END OF SECTION \*\*

**SECTION 020300**  
**CODE REQUIRED SPECIAL INSPECTIONS AND PROCEDURES**

PART 1 - GENERAL

1.1 SUMMARY

- A. Section includes:
1. Requirements for a program to provide code-related special inspections that will be performed by an independent code-required Approved Agency employed by the Owner, or the Registered Design Professional acting as agent of the Owner.
  2. Requirements for removing and replacing Work not conforming to the requirements of the Contract Documents.

1.2 REFERENCES

- A. American Concrete Institute (ACI):
1. ACI 318/318R, Building Code Requirements for Structural Concrete and Commentary.
  2. ACI 530/530R, Building Code Requirements for Masonry Structures and related Commentary (ACI 530/ASCE 5/TMS 402).
  3. ACI 530.1/530.1R, Specifications for Masonry Structures and Related Commentary (ACI530.1/ASCE 6/TMS 602).
- B. American Institute of Steel Construction (AISC):
1. AISC 360, Specification for Structural Steel Buildings.
- C. ASTM International (ASTM):
1. ASTM A6/A6M, Standard Specifications for General Requirements for Rolled Structural Steel Bars, Plates, Shapes, and Steel Piling.
  2. ASTM A568/A568M, Standard Specifications for Steel, Sheet, Carbon, Structural, and High-Strength, Low-Alloy, Hot Rolled and Cold Rolled, General Requirements.
  3. ASTM A706/A706M, Standard Specification for Low-Alloy Steel Deformed and Plain Bars for Concrete Reinforcement.
  4. ASTM C31/C31M, Standard Practice for Making and Curing Concrete Test Specimens in the Field.
  5. ASTM C172, Standard Practice for Sampling Freshly Mixed Concrete.
- D. American Welding Society (AWS):
1. AWS D1.1/D1.1M, Structural Welding Code - Steel.
  2. AWS S3, Structural Welding Code – Sheet Steel.
  3. AWS D1.4/D1.4M, Structural Welding Code – Reinforcing Steel.
- E. International Code Council (ICC):
1. ICC International Building Code (IBC) 2009.

### 1.3 DEFINITIONS

- A. Special Inspection: Observation, inspection, or testing performed by the independent code-required Approved Agency of the materials, installation, fabrication, erection, or placement of components and connections that require special expertise to ensure compliance with the approved construction documents and reference standards.
- B. Special Inspection, Continuous: The full-time observation of work requiring special inspections by an approved special inspector who is present in the area where the work is being performed.
- C. Special Inspection, Periodic: The part-time or intermittent observation of work requiring special inspection by an approved special inspector who is present in the area where the work has been or is being performed and at the completion of the work.
- D. Structural Observation: The visual observation of the structural system by a Registered Design Professional for general conformance to the approved construction documents.
- E. Statement of Special Inspections: A document prepared by the Registered Design Professional indicating that special inspection and/or testing required by the building official, or by the Registered Design Professional responsible for each portion of the Work, is required for the Work of this Contract, and describing in some detail the type and extent of each inspection and test required, including whether or not each will be carried out continuously or periodically.

### 1.4 QUALITY ASSURANCE

- A. Regulatory Requirements:
  - 1. Code-Required Approved Agency:
    - a. The Owner, or the Registered Design Professional acting as Owner's agent, will employ an independent testing and inspection agency to perform the special inspections required by the ICC International Building Code (IBC).
    - b. For the purpose of this contract, the code-required independent testing and inspection agency will be indicated by the term 'Approved Agency'.
    - c. The qualifications for the Approved Agency performing the code-required special inspections and testing are specified in Quality Requirements.
    - d. The Approved Agency must be independent of the contractor.
  - 2. Code Compliance:
    - a. Materials and fabrication procedures provided under this Contract are subject to the requirements of the ICC International Building Code (IBC), must comply with all federal, state, and local codes and ordinances and are subject to special inspections, sampling, and testing in the mill, the shop, and the field in order to verify compliance with IBC.

### 1.5 PROJECT CONDITIONS

- A. For the duration of this Contract and as required by the General Conditions, provide the Owner, the Registered Design Professional, the independent code-required Approved Agency, and the governmental agencies that have jurisdictional interests, assess to the Site and Work at reasonable times for their observation, inspection, and testing.

- B. Give the Approved Agency timely notice of the readiness of the Work for the required inspections, tests, or approvals, as specified in the applicable specification but in no case less than 3 days notice. Cooperate with inspection and testing personnel to facilitate the required inspections and tests.
- C. Uncover existing Work whenever necessary to allow the Work to be inspected or tested by the Approved Agency and other inspection and testing personnel.

## PART 2 - PRODUCTS

### 2.1 SOURCE QUALITY CONTROL

- A. Tests:
  - 1. Materials and fabrication procedures provided under this Contract are subject to testing in the mill and the shop in order to verify compliance with the requirements of the ICC International Building Code (IBC).
  - 2. Each manufacturer of designated seismic system components must test or analyze the component and its mounting system or anchorage, and submit a certificate of compliance for review and acceptance by the Registered Design Professional and for approval by the building official.
- B. Inspection:
  - 1. Special inspections of the fabrication of structural load-bearing members and assemblies in a fabricator's shop are required unless the fabricator is registered and approved to perform such work without special inspection with approval of Engineer, or unless otherwise specified in these specifications.

\*\* END OF SECTION \*\*

## **SECTION 040010 CUTTING AND PATCHING**

### **PART 1 - GENERAL**

#### **1.1 CUTTING AND PATCHING PROPOSAL**

- A. Where approval of procedures is required before proceeding, submit a proposal describing procedures in advance of the time cutting and patching will be performed. Include the following information, as applicable:
1. Describe the extent of cutting and patching required and how it is to be performed. Indicate why it cannot be avoided.
  2. Describe anticipated results, include changes to structural elements and operating components and changes in the building's appearance and other visual elements.
  3. List products to be used and entities that will perform work.
  4. Indicate dates when cutting and patching is to be performed.
  5. List utilities that will be disturbed, including those that will be relocated and those that will be temporarily out-of service. Indicate how long service will be disrupted.
  6. Approval by the Owner's Representative to proceed does not waive the Owner's Representative right to later require complete removal and replacement of work found to be unsatisfactory.

#### **1.2 STRUCTURAL WORK**

- A. Do not cut and patch structural elements in a manner that would reduce the load-carrying capacity or load deflection ratio. Obtain approval of the cutting and patching proposal before cutting and patching structural elements.

#### **1.3 OPERATIONAL AND SAFETY LIMITATIONS**

- A. Do not cut and patch operating elements or safety components in a manner that would reduce their capacity to perform as intended, or would increase maintenance, or decrease operational life or safety. Obtain approval of the cutting and patching proposal before cutting and patching operating elements or safety related systems.

#### **1.4 VISUAL REQUIREMENTS**

- A. Do not cut and patch construction exposed on the exterior or in occupied spaces in a manner that would reduce the building's aesthetic qualities or result in visual evidence of cutting and patching. Remove and replace Work cut and patched in a visually unsatisfactory manner.

## PART 2 - PRODUCTS

### 2.1 MATERIALS

- A. Use materials identical to existing materials. If identical materials are not available or cannot be used where exposed surfaces are involved, use materials that match existing adjacent surfaces to the fullest extent possible. Use materials whose performance will equal or surpass that of existing materials.

## PART 3 - EXECUTION

### 3.1 EXAMINATION

- A. Before cutting, examine surfaces to be cut and patched and conditions under which cutting and patching is to be performed. Take corrective action before proceeding if unsafe or unsatisfactory conditions are encountered.

### 3.2 PREPARATION

- A. Provide temporary support of work to be cut.

### 3.3 CLEANING

- A. Thoroughly clean areas and spaces where cutting and patching is performed or used as access. Remove paint, mortar, oils, putty and similar items. Thoroughly clean piping, conduit, and similar features before painting or finishing is applied. Restore damaged pipe covering to its original condition.

### 3.4 PROTECTION

- A. Protect existing construction during cutting and patching to prevent damage. Provide protection from adverse weather conditions for portions that might be exposed during cutting and patching operations.
- B. Avoid interference with use of adjoining areas or interruption of free passage to adjoining areas.
- C. Take all precautions to avoid cutting existing pipe, conduit, or ductwork serving the building, but scheduled to be removed, or relocated until provisions have been made to bypass them.

### 3.5 PERFORMANCE

- A. Employ skilled workmen to perform cutting and patching. Proceed with cutting and patching at the earliest feasible time and complete without delay.



- B. Cut existing construction to provide for the installation of other components or the performance of other construction activities and the subsequent fitting and patching required to restore surfaces to their original condition.

### 3.6 CUTTING

- A. Cut existing construction using methods least likely to damage elements to be retained or adjoining construction. Where possible, review procedures with the original installer. Comply with the original installer's recommendations.
- B. All cutting of areas shall be by Contractor requiring cutting, except where noted otherwise in the Specifications and/or Drawings.
- C. Where cutting is required, use hand or small power tools designed for sawing or grinding, not hammering and chopping. Cut holes and slots to size required with minimum disturbance of adjacent surfaces. Temporarily cover openings when not in use. To avoid marring existing finished surfaces, cut or drill from the exposed or finished side into concealed surfaces.
- D. Cut through concrete and masonry using a cutting machine such as a carborundum saw or diamond core drill. Overcuts are **not** permitted.

### 3.7 PATCHING

- A. Patch with durable seams that are as invisible as possible. Comply with specified tolerances.
- B. All patching shall be by Contractor doing cutting work and shall be performed by trade who would customarily be performing that type of work.

- C. Restore exposed finishes of patched areas and extend finish restoration into retained adjoining construction in a manner that will eliminate evidence of patching and refinishing.
  - 1. Where patching occurs in a smooth painted surface, extend final paint coat over entire unbroken surface containing the patch, after the patched area has received primer and second coat.
  - 2. Patch, point or grout flush all voids, holes, chips, cracks, spalls, broken or otherwise damaged surfaces. Patch with materials which match adjacent surfaces in appearance and quality
  
- D. Repair surfaces exposed by removed finishes or equipment.

\*\* END OF SECTION \*\*

**SECTION 040020  
CONSTRUCTION WASTE AND DISPOSAL**

PART 1 - GENERAL

1.1 DEFINITIONS

- A. Construction Waste: Building and site improvement materials and other solid waste resulting from construction, remodeling, renovation, or repair operations. Construction waste includes packaging.
- B. Disposal: Removal off-site of construction waste and subsequent sale, recycling, reuse, or deposit in landfill or incinerator acceptable to authorities having jurisdiction.
- C. Salvage and Reuse: Recovery of construction waste and subsequent incorporation into the Work.

1.2 QUALITY ASSURANCE

- A. Regulatory Requirements: Comply with hauling and disposal regulations of authorities having jurisdiction.

PART 2 - RODUCTS (not used)

PART 3 - EXECUTION

3.1 DISPOSAL OF WASTE

- A. General: Except for items or materials to be salvaged, recycled, or otherwise reused, remove waste materials from Project site and legally dispose of them in a landfill or incinerator acceptable to authorities having jurisdiction.
  - 1. Except as otherwise specified, do not allow waste materials that are to be disposed of accumulate on-site.
  - 2. Remove and transport debris in a manner that will prevent spillage on adjacent surfaces and areas.
- B. Burning: Do not burn waste materials.
- C. Disposal: Transport waste materials off Owner's property and legally dispose of them.

**\*\* END OF SECTION \*\***

**SECTION 060010**  
**TEMPORARY FACILITIES AND CONTROLS**

PART 1 - GENERAL

1.1 SUMMARY

- A. This section includes requirements for temporary facilities and controls, including temporary utilities, support facilities, and security and protection facilities.
- B. Temporary utilities include, but are not limited to, the following:
  - 1. Temporary Sanitary facilities, including toilets, wash facilities, and drinking-water facilities.
  - 2. Temporary Ventilation.
  - 3. Telephone and Electric service.
  - 4. Temporary heat.
  - 5. Temporary lighting.
- C. Support facilities include, but are not limited to, the following:
  - 1. Temporary roads and paving.
  - 2. Temporary Field Office Trailer.
  - 3. Dewatering facilities and drains.
  - 4. Project identification and temporary signs.
  - 5. Waste disposal facilities.
  - 6. Lifts and hoists.
  - 7. Construction aids and miscellaneous services and facilities.
  - 8. Self contained Toilet Units.
- D. Security and protection facilities include, but are not limited to, the following:
  - 1. Environmental protection.
  - 2. Stormwater control.
  - 3. Pest control.
  - 4. Site enclosure fence.
  - 5. Security enclosure and lockup.
  - 6. Barricades, warning signs and lights.
  - 7. Temporary enclosures.
  - 8. Temporary partitions.
  - 9. Fire Protection.

## 1.2 DEFINITIONS

- A. Permanent Enclosure: As determined by Owner, permanent or temporary roofing is complete, insulated, and weather tight; exterior walls are insulated and weather tight; and all openings are closed with permanent construction or substantial temporary closures.

## 1.3 USE CHARGES

- A. General: Cost or use charges for temporary facilities shall be included in the Contract Sum. Allow other entities to use temporary services and facilities without cost, including, but not limited to, Owner's construction forces, Owner, occupants of Project, testing agencies, and authorities having jurisdiction.
- B. Sewer Service: Pay sewer service use charges for sewer usage by all entities for construction operations.
- C. Water Service: Pay water service use charges for water used by all entities for construction operations.
- D. Electric Power Service: Pay electric power service use charges for electricity used by all entities for construction operations.
- E. Telephone / Fax Service: Pay for telephone use charges for telephone used by all entities for construction operations.

## 1.4 SUBMITTALS

- A. Temporary Utility Reports: Submit reports of tests, inspections, meter readings, and similar procedures performed on temporary utilities.
- B. Implementation and Termination Schedule: Within 15 days of date established for submittal of Construction Manager's Construction Schedule, submit a schedule indicating implementation and termination of each temporary utility.

## 1.5 QUALITY ASSURANCE

- A. Standards: Comply with ANSI A10.6, NECA's "Temporary Electrical Facilities," and NFPA 241.
  - 1. Trade Jurisdictions: Assigned responsibilities for installation and operation of temporary utilities are not intended to interfere with trade regulations and union jurisdictions.
  - 2. Electric Service: Comply with NECA, NEMA, and UL standards and regulations for temporary electric service. Install service to comply with NFPA 70.
- B. Tests and Inspections: Arrange for authorities having jurisdiction to test and inspect each temporary utility before use. Obtain required certifications and permits.

## 1.6 PROJECT CONDITIONS

- A. Temporary Utilities: At earliest feasible time, when acceptable to Owner, change over from use of temporary service to use of permanent service.
  - 1. Temporary Use of Permanent Facilities: Installer of each permanent service shall assume responsibility for operation, maintenance, and protection of each permanent service during its use as a construction facility before Owner's acceptance, regardless of previously assigned responsibilities.
- B. Conditions of Use: The following conditions apply to use of temporary services and facilities by all parties engaged in the Work:
  - 1. Keep temporary services and facilities clean and neat.
  - 2. Relocate temporary services and facilities as required by progress of the Work.

## PART 2 – PRODUCTS

### 2.1 MATERIALS

- A. General: Provide new materials. Undamaged, previously used materials in serviceable condition may be used if approved by Owner. Provide materials suitable for use intended.
- B. Gypsum Board: 5/8 inch thick by 48 inches wide by maximum available lengths; Type X panels with tapered edges. Comply with ASTM C 36.
- C. Insulation: Un-faced mineral fiber blanket, manufactured from glass, slag wool, or rock wool; with maximum flame-spread and smoke developed indices of 25 and 50, respectively.
- D. Paint: Comply with requirements in Division 24 Sections "Interior and Exterior Painting."

- E. Tarpaulins: Fire resistive labeled with flame spread rating of 15 or less.
- F. Water: Potable.

## 2.2 EQUIPMENT

- A. General: Provide equipment suitable for use intended.
- B. Fire Extinguishers: Hand carried, portable, UL rated. Provide class and extinguishing agent as indicated or a combination of extinguishers of NFPA-recommended classes for exposures.
  - 1. Comply with NFPA 10 and NFPA 241 for classification, extinguishing agent, and size required by location and class of fire exposure.
- C. Self-Contained Toilet Units: Single occupant units of chemical, aerated re-circulation, or combustion type; vented; fully enclosed with a glass-fiber-reinforced polyester shell or similar nonabsorbent material.
- D. Power Distribution System Circuits: Where permitted and overhead and exposed for surveillance, wiring circuits, not exceeding 125-V ac, 20-A rating, and lighting circuits may be nonmetallic sheathed cable.

## PART 3 – EXECUTION

### 3.1 INSTALLATION, GENERAL

- A. Locate facilities where they will serve Project adequately and result in minimum interference with performance of the Work. Relocate and modify facilities as required.
- B. Provide each facility ready for use when needed to avoid delay. Maintain and modify as required. Do not remove until facilities are no longer needed or are replaced by authorized use of completed permanent facilities.

### 3.2 TEMPORARY UTILITY INSTALLATION

- A. Water Service: Install water service and distribution piping in sizes and pressures adequate for construction activities from Owner's existing water service.
  - 1. Provide rubber hoses as necessary to serve Project site.
  - 2. Where installations below an outlet might be damaged by spillage or leakage, provide a drip pan of suitable size to minimize water damage. Drain accumulated water promptly from pans.
  - 3. Provide pumps to supply a minimum of 30-psi static pressure at highest point. Equip pumps with surge and storage tanks and automatic controls to supply water uniformly at reasonable pressures.
- B. Sewers and Drainage: Provide temporary utilities to remove effluent lawfully.

1. Connect temporary sewers to municipal system as directed by authorities having jurisdiction.
- C. Sanitary Facilities: Provide temporary toilets, wash facilities, and drinking water fixtures. Comply with regulations and health codes for type, number, location, operation, and maintenance of fixtures and facilities.
1. Disposable Supplies: Provide toilet tissue, paper towels, paper cups, and similar disposable materials for each facility. Maintain adequate supply. Provide covered waste containers for disposal of used material.
  2. Toilets: Install self contained toilet units. Shield toilets to ensure privacy.
  3. Drinking Water Facilities: Provide bottle-water, drinking-water units.
    - a. Where power is accessible, provide electric water coolers to maintain dispensed water temperature at 45 to 55 deg F.
  4. Locate toilets so personnel need not walk more than two stories vertically or 200 feet horizontally to facilities.
- D. Heating and Cooling: Provide temporary heating and cooling required by construction activities for curing or drying of completed installations or for protecting installed construction from adverse effects of low temperatures or high humidity. Select equipment from that specified that will not have a harmful effect on completed installations or elements being installed.
1. Maintain a minimum temperature as necessary, so as not to delay the project, in permanently enclosed portions of building for normal construction activities.
- E. Ventilation and Humidity Control: Provide temporary ventilation required by construction activities for curing or drying of completed installations or for protecting installed construction from adverse effects of high humidity. Select equipment from that specified that will not have a harmful effect on completed installations or elements being installed. Coordinate ventilation requirements to produce ambient condition required and minimize energy consumption.
- F. Electric Power Service: Provide electric power service and distribution system of sufficient size, capacity, and power characteristics required for construction operations from Owner's existing electric service.
1. Install electric power service overhead, unless otherwise indicated.
- G. Electric Distribution: Provide receptacle outlets adequate for connection of power tools and equipment.
1. Provide waterproof connectors to connect separate lengths of electrical power cords if single lengths will not reach areas where construction activities are in progress. Do not exceed safe length-voltage ratio.
  2. Provide warning signs at power outlets other than 110 to 120 V.



3. Provide metal conduit, tubing, or metallic cable for wiring exposed to possible damage. Provide rigid steel conduits for wiring exposed on grades, floors, decks, or other traffic areas.
  4. Provide metal conduit enclosures or boxes for wiring devices.
  5. Provide 4-gang outlets, spaced so 100 foot extension cord can reach each area for power hand tools and task lighting. Provide a separate 125-V ac, 20-A circuit for each outlet.
- H. Lighting: Provide temporary lighting with local switching that provides adequate illumination for construction operations and traffic conditions.
- I. Telephone Service: Provide temporary telephone service in common-use facilities for use by all construction personnel extended from Owner's existing service. Install one telephone line(s) for each field office.
1. Post a list of important telephone numbers.
    - a. Police and fire departments.
    - b. Ambulance service.
    - c. Construction Manager's home office.
    - d. Architect's home office.
    - e. Engineer's home office.
    - f. Owner's office.
    - g. Principal subcontractors' field and home office.
  2. Provide an answering machine on superintendent's telephone.
  3. Furnish superintendent with electronic paging device or portable two-way radio for use when away from field office.
  4. Provide a portable cellular telephone for superintendent's use in making and receiving telephone calls when away from field office.

### 3.3 SUPPORT FACILITIES INSTALLATION

- A. General: Comply with the following:
1. Locate sanitary facilities, and other temporary construction and support facilities for easy access.
  2. Provide incombustible construction for offices, shops, and sheds located within construction area or within 30 feet of building lines. Comply with NFPA 241.
  3. Maintain support facilities until near Substantial Completion. Remove before Substantial Completion. Personnel remaining after Substantial Completion will be permitted to use permanent facilities, under conditions acceptable to Owner.
- B. Temporary Roads and Paved Areas: Construct and maintain temporary roads and paved areas adequate for construction operations. Locate temporary roads and paved areas on Drawings.
1. Provide dust control treatment that is nonpolluting and non-tracking. Reapply treatment as required to minimize dust.

2. Prepare subgrade and install sub base and base for temporary roads and paved areas.
  3. Recondition base after temporary use, including removing contaminated material, re-grading, proof-rolling, compacting, and testing.
  4. Delay installation of final course of permanent hot-mix asphalt pavement until immediately before Substantial Completion. Repair asphalt base-course pavement before installation of final course in accordance with Division 28 Section "Asphalt Paving."
- C. Parking: Provide temporary parking areas for construction personnel.
- D. De-watering Facilities and Drains: Comply with requirements in applicable Site Sections for temporary drainage and dewatering facilities and operations not directly associated with construction activities included in individual Sections. Where feasible, use same facilities. Maintain Project site, excavations, and construction free of water.
1. Dispose of rainwater in a lawful manner that will not result in flooding Project or adjoining property nor endanger permanent Work or temporary facilities.
  2. Before connection and operation of permanent drainage piping system, provide temporary drainage where roofing or similar waterproof deck construction is completed.
- E. Project Identification and Temporary Signs: Prepare Project identification and other signs in sizes approved by the Owner and Architect. Install signs to inform public and persons seeking entrance to Project. Do not permit installation of unauthorized signs.
1. Engage an experienced sign painter to apply graphics for Project identification signs. Comply with details indicated.
  2. Prepare temporary signs to provide directional information to construction personnel and visitors.
  3. Construct signs of exterior-type Grade B-B high-density concrete form overlay plywood in sizes and thicknesses indicated. Support on posts or framing of preservative-treated wood or steel.
  4. Paint sign panel and applied graphics with exterior-grade alkyd gloss enamel over exterior primer.
- F. Waste Disposal Facilities: Provide waste-collection containers in sizes adequate to handle waste from construction operations. Containerize and clearly label hazardous, dangerous, or unsanitary waste materials separately from other waste. Comply with Division 1 Section "Execution Requirements" for progress cleaning requirements.
1. If required by authorities having jurisdiction, provide separate containers, clearly labeled, for each type of waste material to be deposited.
  2. Develop a waste management plan for Work performed on Project. Indicate types of waste materials Project will produce and estimate quantities of each type. Provide detailed information for on-site waste storage and separation of recyclable materials. Provide information on destination of each type of waste material and means to be used to dispose of all waste materials.

- G. Lifts and Hoists: Provide facilities for hoisting materials and personnel. Truck cranes and similar devices used for hoisting materials are considered "tools and equipment" and not temporary facilities.
- H. Temporary Stairs: Until permanent stairs are available, provide temporary stairs where ladders are not adequate.
- I. Temporary Use of Permanent Stairs: Cover finished, permanent stairs with protective covering of plywood or similar material so finishes will be undamaged at time of acceptance.

#### 3.4 TEMPORARY FIELD OFFICE TRAILER

- A. Trailer: Provide temporary field office trailer within security enclosure. Portable trailer to be anchored to site on cmu. Provide built-in stairs to access temporary trailer.
- B. Office: Provide temporary fax machine, copier, telephone, and computer in the Trailer for Contractor, Owner, and Architect use. Provide table and chairs capable of seating 20 people for Job Conferences and Subcontractor Meetings.
- C. Documents: Maintain a complete set of Construction Documents, Permits, Emergency Contacts, Addenda, Bulletins, progress photos, and approved Shop Drawings in the Office Trailer for field use. All documents are to be turned over to the Owner as part of the O&M Manuals for record.

#### 3.5 SECURITY AND PROTECTION FACILITIES INSTALLATION

- A. Temporary Erosion and Sedimentation Control: Provide measures to prevent soil erosion and discharge of soil-bearing water runoff and airborne dust to adjacent properties and walkways, according to requirements of authorities having jurisdiction.
- B. Environmental Protection: Provide protection, operate temporary facilities, and conduct construction in ways and by methods that comply with environmental regulations and that minimize possible air, waterway, and subsoil contamination or pollution or other undesirable effects. Avoid using tools and equipment that produce harmful noise. Restrict use of noisemaking tools and equipment to hours that will minimize complaints from persons or firms near Project site.
- C. Stormwater Control: Provide earthen embankments and similar barriers in and around excavations and subgrade construction, sufficient to prevent flooding by runoff of stormwater from heavy rains.
- D. Pest Control: Before foundation work has been completed, retain a local exterminator or pest-control company to recommend practices to minimize attraction and harboring of rodents, roaches, and other pests. Engage this pest control service to perform extermination and control procedures at regular intervals so Project will be free of pests and their residues at Substantial Completion. Obtain extended warranty for Owner. Perform control operations lawfully, using environmentally safe materials.

- E. Barricades, Warning Signs, and Lights: Comply with standards and code requirements for erecting structurally adequate barricades. Paint with appropriate colors, graphics, and warning signs to inform personnel and public of possible hazard. Where appropriate and needed, provide lighting, including flashing red or amber lights.
  - 1. For safety barriers, sidewalk bridges, and similar uses, provide minimum 5/8-inch-thick exterior plywood.
- F. Temporary Partitions: Erect and maintain dustproof partitions and temporary enclosures to limit dust and dirt migration and to separate areas from fumes and noise.
  - 1. Construct dustproof, floor-to-ceiling barriers of polyethylene sheets.
- G. Security Enclosure: Chain link fence surrounding entire project site with lockable gates. Provide monitored locking system. Coordinate gate locations with Owner.
- H. Temporary Fire Protection: Until fire protection needs are supplied by permanent facilities, install and maintain temporary fire-protection facilities of types needed to protect against reasonably predictable and controllable fire losses. Comply with NFPA 241.
  - 1. Provide fire extinguishers, installed on walls on mounting brackets, visible and accessible from space being served, with sign mounted above.
    - a. Field Offices: Class A stored-pressure water type extinguishers.
    - b. Other Locations: Class ABC dry-chemical extinguishers or a combination of extinguishers of NFPA-recommended classes for exposures.
    - c. Locate fire extinguishers where convenient and effective for their intended purpose; provide not less than one extinguisher on each floor at or near each usable stairwell.
  - 2. Store combustible materials in containers in fire safe locations.
  - 3. Maintain unobstructed access to fire extinguishers, fire hydrants, temporary fire-protection facilities, stairways, and other access routes for firefighting. Prohibit smoking in hazardous fire-exposure areas.
  - 4. Supervise welding operations, combustion-type temporary heating units, and similar sources of fire ignition.

### 3.6 OPERATION, TERMINATION AND REMOVAL

- A. Supervision: Enforce strict discipline in use of temporary facilities. To minimize waste and abuse, limit availability of temporary facilities to essential and intended uses.
- B. Maintenance: Maintain facilities in good operating condition until removal. Protect from damage caused by freezing temperatures and similar elements.
  - 1. Maintain operation of temporary enclosures, heating, cooling, humidity control, ventilation, and similar facilities on a 24-hour basis where required to achieve indicated results and to avoid possibility of damage.

2. Prevent water filled piping from freezing. Maintain markers for underground lines. Protect from damage during excavation operations.
- C. Temporary Facility Changeover: Except for using permanent fire protection as soon as available, do not change over from using temporary security and protection facilities to permanent facilities until Substantial Completion.
- D. Termination and Removal: Remove each temporary facility when need for its service has ended, when it has been replaced by authorized use of a permanent facility, or no later than Substantial Completion. Complete or, if necessary, restore permanent construction that may have been delayed because of interference with temporary facility. Repair damaged Work, clean exposed surfaces, and replace construction that cannot be satisfactorily repaired.
1. Materials and facilities that constitute temporary facilities are the property of Construction Manager. Owner reserves right to take possession of Project identification signs.
  2. Remove temporary paving not intended for or acceptable for integration into permanent paving. Where area is intended for landscape development, remove soil and aggregate fill that do not comply with requirements for fill or subsoil. Remove materials contaminated with road oil, asphalt and other petrochemical compounds, and other substances that might impair growth of plant materials or lawns. Repair or replace street paving, curbs, and sidewalks at temporary entrances, as required by authorities having jurisdiction.
  3. At Substantial Completion, clean and renovate permanent facilities used during construction period. Comply with final cleaning requirements in Division 34 Section "Closeout Procedures".

\*\* END OF SECTION \*\*

**SECTION 060020**  
**TEMPORARY TREE AND PLANT PROTECTION**

PART 1 - GENERAL

1.1 SUMMARY

- A. Section includes general protection and pruning of existing trees and plants that are affected by execution of the Work, whether temporary or permanent construction.
- B. Related Sections:
  - 1. Section 06 "Temporary Facilities and Controls" for temporary site fencing.
  - 2. Section 28 "Site Clearing" for removing existing trees and shrubs.

1.2 DEFINITIONS

- A. Caliper: Diameter of a trunk measured by a diameter tape at 6 inches above the ground for trees up to, and including, 4-inch size; and 12 inches above the ground for trees larger than 4-inch size.
- B. Plant-Protection Zone: Area surrounding individual trees, groups of trees, shrubs, or other vegetation to be protected during construction, and indicated on Drawings.
- C. Tree-Protection Zone: Area surrounding individual trees or groups of trees to be protected during construction.
- D. Vegetation: Trees, shrubs, groundcovers, grass, and other plants.

1.3 ACTION SUBMITTALS

- A. Product Data: For each type of product indicated.
- B. Samples for Verification: For each type of the following:
  - 1. Organic Mulch: 1-quart volume of organic mulch; in sealed plastic bags labeled with composition of materials by percentage of weight and source of mulch.
  - 2. Protection-Zone Fencing: Assembled Samples of manufacturer's standard size made from full-size components.

- C. Tree Pruning Schedule: Written schedule detailing scope and extent of pruning of trees to remain that interfere with or are affected by construction.
  - 1. Species and size of tree.
  - 2. Location on site plan. Include unique identifier for each.
  - 3. Reason for pruning.
  - 4. Description of pruning to be performed.
  - 5. Description of maintenance following pruning.

#### 1.4 INFORMATIONAL SUBMITTALS

- A. Qualification Data: For qualified arborist and tree service firm.
- B. Certification: From arborist, certifying that trees indicated to remain have been protected during construction according to recognized standards and that trees were promptly and properly treated and repaired when damaged.
- C. Maintenance Recommendations: From arborist, for care and protection of trees affected by construction during and after completing the Work.
- D. Existing Conditions: Documentation of existing trees and plantings indicated to remain, which establishes preconstruction conditions that might be misconstrued as damage caused by construction activities.
  - 1. Use sufficiently detailed photographs or videotape.
  - 2. Include plans and notations to indicate specific wounds and damage conditions of each tree or other plants designated to remain.

#### 1.5 QUALITY ASSURANCE

- A. Arborist Qualifications: Licensed arborist in jurisdiction where Project is located.
- B. Tree Service Firm Qualifications: An experienced tree service firm that has successfully completed temporary tree and plant protection work similar to that required for this Project and that will assign an experienced, qualified arborist to Project site during execution of the Work.
- C. Pre-installation Conference: Conduct conference at Project site.
  - 1. Review methods and procedures related to temporary tree and plant protection including, but not limited to, the following:
    - a. Construction schedule. Verify availability of materials, personnel, and equipment needed to make progress and avoid delays.
    - b. Enforcing requirements for protection zones.
    - c. Arborist's responsibilities.
    - d. Field quality control.

## 1.6 PROJECT CONDITIONS

- A. The following practices are prohibited within protection zones:
  - 1. Storage of construction materials, debris, or excavated material.
  - 2. Parking vehicles or equipment.
  - 3. Foot traffic.
  - 4. Erection of sheds or structures.
  - 5. Impoundment of water.
  - 6. Excavation or other digging unless otherwise indicated.
  - 7. Attachment of signs to or wrapping materials around trees or plants unless otherwise indicated.
- B. Do not direct vehicle or equipment exhaust toward protection zones.
- C. Prohibit heat sources, flames, ignition sources, and smoking within or near protection zones and organic mulch.

## PART 2 - PRODUCTS

### 2.1 MATERIALS

- A. Topsoil: Natural or cultivated top layer of the soil profile or manufactured topsoil; containing organic matter and sand, silt, and clay particles; friable, pervious, and black or a darker shade of brown, gray, or red than underlying subsoil; reasonably free of subsoil, clay lumps, gravel, and other objects more than 1 inch in diameter; and free of weeds, roots, and toxic and other nonsoil materials.
  - 1. Obtain topsoil only from well-drained sites where topsoil is 4 inches deep or more; do not obtain from bogs or marshes.
- B. Topsoil: Imported or manufactured topsoil complying with ASTM D 5268.
- C. Organic Mulch: Free from deleterious materials and suitable as a top dressing for trees and shrubs, consisting of one of the following:
  - 1. Type: Shredded hardwood.
  - 2. Size Range: 3 inches maximum, 1/2 inch minimum.
  - 3. Color: Natural.
- D. Protection-Zone Fencing: Fencing fixed in position and meeting the following requirements.
  - 1. Plastic Protection-Zone Fencing: Plastic construction fencing constructed of high-density extruded and stretched polyethylene fabric with 2-inch maximum opening in pattern and weighing a minimum of 0.4 lb/ft.; remaining flexible from minus 60 to plus 200 deg F; inert to most chemicals and acids; minimum tensile yield strength of 2000 psi and ultimate tensile strength of 2680 psi; secured with plastic bands or galvanized-steel or



stainless-steel wire ties; and supported by tubular or T-shape galvanized-steel posts spaced not more than 8 feet apart.

- a. Height: 4 feet.
- b. Color: High-visibility orange, non-fading.

## PART 3 - EXECUTION

### 3.1 EXAMINATION

- A. Erosion and Sedimentation Control: Examine the site to verify that temporary erosion- and sedimentation-control measures are in place. Verify that flows of water redirected from construction areas or generated by construction activity do not enter or cross protection zones.
- B. For the record, prepare written report, endorsed by arborist, listing conditions detrimental to tree and plant protection.

### 3.2 PREPARATION

- A. Locate and clearly identify trees, shrubs, and other vegetation to remain or to be relocated. Flag each tree trunk at 54 inches above the ground.
- B. Protect tree root systems from damage caused by runoff or spillage of noxious materials while mixing, placing, or storing construction materials. Protect root systems from ponding, eroding, or excessive wetting caused by dewatering operations.
- C. Tree-Protection Zones: Mulch areas inside tree-protection zones and other areas indicated.
  1. Apply 4-inch average thickness of organic mulch. Do not place mulch within 6 inches of tree trunks.

### 3.3 TREE- AND PLANT-PROTECTION ZONES

- A. Protection-Zone Fencing: Install protection-zone fencing along edges of protection zones before materials or equipment are brought on the site and construction operations begin in a manner that will prevent people and animals from easily entering protected area except by entrance gates. Construct fencing so as not to obstruct safe passage or visibility at vehicle intersections where fencing is located adjacent to pedestrian walkways or in close proximity to street intersections, drives, or other vehicular circulation.
- B. Maintain protection zones free of weeds and trash.
- C. Repair or replace trees, shrubs, and other vegetation indicated to remain or be relocated that are damaged by construction operations, in a manner approved by University.

- D. Maintain protection-zone fencing and signage in good condition as acceptable to University and remove when construction operations are complete and equipment has been removed from the site.
  - 1. Do not remove protection-zone fencing, even temporarily, to allow deliveries or equipment access through the protection zone.
  - 2. Temporary access is permitted subject to preapproval in writing by arborist if a root buffer effective against soil compaction is constructed as directed by arborist. Maintain root buffer so long as access is permitted.

### 3.4 EXCAVATION

- A. General: Excavate at edge of protection zones and for trenches indicated within protection zones according to requirements in Section 28 "Earth Moving."
- B. Trenching near Trees: Where utility trenches are required within protection zones, hand excavate under or around tree roots or tunnel under the roots by drilling, auger boring, or pipe jacking. Do not cut main lateral tree roots or taproots; cut only smaller roots that interfere with installation of utilities. Cut roots as required for root pruning.
- C. Redirect roots in backfill areas where possible. If encountering large, main lateral roots, expose roots beyond excavation limits as required to bend and redirect them without breaking. If encountered immediately adjacent to location of new construction and redirection is not practical, cut roots approximately 3 inches back from new construction and as required for root pruning.
- D. Do not allow exposed roots to dry out before placing permanent backfill. Provide temporary earth cover or pack with peat moss and wrap with burlap. Water and maintain in a moist condition. Temporarily support and protect roots from damage until they are permanently relocated and covered with soil.

### 3.5 ROOT PRUNING

- A. Prune roots that are affected by temporary and permanent construction. Prune roots as follows:
  - 1. Cut roots manually by digging a trench and cutting exposed roots with sharp pruning instruments; do not break, tear, chop, or slant the cuts. Do not use a backhoe or other equipment that rips, tears, or pulls roots.
  - 2. Cut Ends: Coat cut ends of roots more than 1-1/2 inches in diameter with an emulsified asphalt or other coating formulated for use on damaged plant tissues and that is acceptable to arborist.
  - 3. Temporarily support and protect roots from damage until they are permanently redirected and covered with soil.
  - 4. Cover exposed roots with burlap and water regularly.
  - 5. Backfill as soon as possible according to requirements in Section 28 "Earth Moving."
- B. Root Pruning at Edge of Protection Zone: Prune roots flush with the edge of the protection zone, by cleanly cutting all roots to the depth of the required excavation.

- C. Root Pruning within Protection Zone: Clear and excavate by hand to the depth of the required excavation to minimize damage to root systems. Use narrow-tine spading forks, comb soil to expose roots, and cleanly cut roots as close to excavation as possible.

### 3.6 CROWN PRUNING

- A. Prune branches that are affected by temporary and permanent construction. Prune branches as follows:
  - 1. Prune trees to remain to compensate for root loss caused by damaging or cutting root system. Provide subsequent maintenance during Contract period as recommended by arborist.
  - 2. Pruning Standards: Prune trees according to ANSI A300 (Part 1), and the following:
    - a. Type of Pruning: Reduction.
    - b. Specialty Pruning: Restoration.
  - 3. Cut branches with sharp pruning instruments; do not break or chop.
  - 4. Do not apply pruning paint to wounds.
- B. Chip removed branches and dispose of off-site.

### 3.7 REGRADING

- A. Lowering Grade: Where new finish grade is indicated below existing grade around trees, slope grade beyond the protection zone. Maintain existing grades within the protection zone.
- B. Lowering Grade within Protection Zone: Where new finish grade is indicated below existing grade around trees, slope grade away from trees as recommended by arborist unless otherwise indicated.
  - 1. Root Pruning: Prune tree roots exposed by lowering the grade. Do not cut main lateral roots or taproots; cut only smaller roots. Cut roots as required for root pruning.
- C. Raising Grade: Where new finish grade is indicated above existing grade around trees, slope grade beyond the protection zone. Maintain existing grades within the protection zone.
- D. Minor Fill within Protection Zone: Where existing grade is 2 inches or less below elevation of finish grade, fill with topsoil. Place topsoil in a single un-compacted layer and hand grade to required finish elevations.

### 3.8 FIELD QUALITY CONTROL

- A. Inspections: Engage a qualified arborist to direct plant-protection measures in the vicinity of trees, shrubs, and other vegetation indicated to remain and to prepare inspection reports.

### 3.9 REPAIR AND REPLACEMENT

- A. General: Repair or replace trees, shrubs, and other vegetation indicated to remain or be relocated that are damaged by construction operations, in a manner approved by Owner.
  - 1. Submit details of proposed root cutting and tree and shrub repairs.
  - 2. Have arborist perform the root cutting, branch pruning, and damage repair of trees and shrubs.
  - 3. Treat damaged trunks, limbs, and roots according to arborist's written instructions.
  - 4. Perform repairs within 24 hours.
  - 5. Replace vegetation that cannot be repaired and restored to full-growth status, as determined by Owner.
- B. Trees: Remove and replace trees indicated to remain that are more than 25 percent dead or in an unhealthy condition before the end of the corrections period or are damaged during construction operations that Owner determines are incapable of restoring to normal growth pattern.
  - 1. Provide new trees of same size and species as those being replaced for each tree that measures 6 inches or smaller in caliper size.
  - 2. Provide one new tree of 6-inch caliper size for each tree being replaced that measures more than 6 inches in caliper size.
    - a. Species: Species selected by Owner.
- C. Soil Aeration: Aerate surface soil compacted during construction. Aerate 10 feet beyond drip line and no closer than 36 inches to tree trunk. Drill 2-inch diameter holes a minimum of 12 inches deep at 24 inches o.c. Backfill holes with an equal mix of augered soil and sand.

### 3.10 DISPOSAL OF SURPLUS AND WASTE MATERIALS

- A. Disposal: Remove excess excavated material, displaced trees, trash and debris, and legally dispose of them off Owner's property.

\*\* END OF SECTION \*\*

**SECTION 080010  
ETHYLENE PROPYLENE DIENE MONOMER  
(EPDM) ROOFING**

**PART 1 - GENERAL**

**1.1 SUMMARY**

**A. Section Includes:**

1. Adhered EPDM membrane roofing system.
2. Rigid roof insulation.

**B. Related Sections:**

1. Section 06 "Roof Specialties" for manufactured copings.
2. Section 24 "Joint Sealants" for joint sealants, joint fillers, and joint preparation.
3. Section 12 "Storm Drainage Piping Specialties" for roof drains.

**1.2 DEFINITIONS**

- A. Roofing Terminology:** See ASTM D 1079 and glossary of NRCA's "The NRCA Roofing and Waterproofing Manual" for definitions of terms related to roofing work in this Section.

**1.3 PERFORMANCE REQUIREMENTS**

- A. General Performance:** Installed membrane roofing and base flashings shall withstand specified uplift pressures, thermally induced movement, and exposure to weather without failure due to defective manufacture, fabrication, installation, or other defects in construction. Membrane roofing and base flashings shall remain watertight.
- B. Material Compatibility:** Provide roofing materials that are compatible with one another under conditions of service and application required, as demonstrated by membrane roofing Manufacturer based on testing and field experience.

- C. Roofing System Design: Provide membrane roofing system that is identical to systems that have been successfully tested by a qualified testing and inspecting agency to resist uplift pressure calculated according to ASCE/SEI 7.
  - 1. Corner Uplift Pressure: 50 lbf/sq. ft.
  - 2. Perimeter Uplift Pressure: 34 lbf/sq. ft.
  - 3. Field-of-Roof Uplift Pressure: 20 lbf/sq. ft.
  - 4. Unless noted otherwise on structural drawings.
  
- D. FM Approvals Listing: Provide membrane roofing, base flashings, and component materials that comply with requirements in FM Approvals 4450 and FM Approvals 4470 as part of a membrane roofing system, and that are listed in FM Approvals' "RoofNav" for Class 1 or noncombustible construction, as applicable. Identify materials with FM Approvals' markings.
  - 1. Fire / Windstorm Classification: Class 1A-90. Basic wind speed for 3 second gust to be 90 MPH which equates to a 75 MPH fastest wind speed. 90 MPH requirement applies to entire roof system including fasteners.
  - 2. Hail Resistance: MH.

#### 1.4 SUBMITTALS

- A. Product Data: For each type of product indicated.
  
- B. Shop Drawings: For roofing system. Include plans, elevations, sections, details, and attachments to other work.
  - 1. Base flashings and membrane terminations.
  - 2. Tapered insulation, including slopes.
  - 3. Roof plan showing orientation of steel roof deck and orientation of membrane roofing and fastener spacing and patterns for mechanically fastened membrane roofing.
  - 4. Insulation fastener patterns for corner, perimeter, and field-of-roof locations.
  
- C. Samples for Verification: For the following products, in Manufacturer's standard sizes:
  - 1. Sheet roofing, of color specified, including T-shaped side and end lap seam.
  - 2. Roof insulation.
  - 3. Walkway pads.
  - 4. Termination bars.
  - 5. Battens.
  - 6. Six insulation fasteners of each type, length, and finish.
  - 7. Six roof cover fasteners of each type, length, and finish.
  
- D. Qualification Data: For qualified Installer and Manufacturer.
  
- E. Manufacturer Certificate: Signed by roofing Manufacturer certifying that membrane roofing system complies with requirements specified in "Performance Requirements" Article.
  - 1. Submit evidence of complying with performance requirements.

- F. Product Test Reports: Based on evaluation of comprehensive tests performed by Manufacturer and witnessed by a qualified testing agency, for components of membrane roofing system.
- G. Research / Evaluation Reports: For components of membrane roofing system, from the ICC-ES.
- H. Field quality-control reports.
- I. Maintenance Data: For membrane roofing system to include in maintenance manuals.
- J. Warranties: Sample of special warranties.

## 1.5 QUALITY ASSURANCE

- A. Manufacturer Qualifications: A qualified Manufacturer that is UL listed and FM Approvals approved for membrane roofing system identical to that used for this Project.
- B. Installer Qualifications: A qualified firm that is approved, authorized, or licensed by membrane roofing system Manufacturer to install Manufacturer's product and that is eligible to receive Manufacturer's special warranty.
- C. Source Limitations: Obtain components including roof insulation and fasteners for membrane roofing system from same Manufacturer as membrane roofing or approved by membrane roofing Manufacturer.
- D. Fire Resistance Ratings: Where indicated, provide fire-resistance-rated roof assemblies identical to those of assemblies tested for fire resistance per ASTM E 119 by a qualified testing agency. Identify products with appropriate markings of applicable testing agency.
- E. Pre-installation Roofing Conference: Conduct conference at Project site.
  1. if applicable, testing and inspecting agency representative, roofing Installer, roofing system Manufacturer's representative, deck Installer, and installers whose work interfaces with or affects roofing, including installers of roof accessories and roof-mounted equipment.
  2. Review methods and procedures related to roofing installation, including Manufacturer's written instructions.
  3. Review and finalize construction schedule and verify availability of materials, Installer's personnel, equipment, and facilities needed to make progress and avoid delays.
  4. Examine deck substrate conditions and finishes for compliance with requirements, including flatness and fastening.
  5. Review structural loading limitations of roof deck during and after roofing.
  6. Review base flashings, special roofing details, roof drainage, roof penetrations, equipment curbs, and condition of other construction that will affect roofing system.
  7. Review governing regulations and requirements for insurance and certificates if applicable.
  8. Review temporary protection requirements for roofing system during and after installation.
  9. Review roof observation and repair procedures after roofing installation.

## 1.6 DELIVERY, STORAGE, AND HANDLING

- A. Deliver roofing materials to Project site in original containers with seals unbroken and labeled with Manufacturer's name, product brand name and type, date of manufacture, approval or listing agency markings, and directions for storing and mixing with other components.
- B. Store liquid materials in their original undamaged containers in a clean, dry, protected location and within the temperature range required by roofing system Manufacturer. Protect stored liquid material from direct sunlight.
  - 1. Discard and legally dispose of liquid material that cannot be applied within its stated shelf life.
- C. Protect roof insulation materials from physical damage and from deterioration by sunlight, moisture, soiling, and other sources. Store in a dry location. Comply with insulation Manufacturer's written instructions for handling, storing, and protecting during installation.
- D. Handle and store roofing materials and place equipment in a manner to avoid permanent deflection of deck.

## 1.7 PROJECT CONDITIONS

- A. Weather Limitations: Proceed with installation only when existing and forecasted weather conditions permit roofing system to be installed according to Manufacturer's written instructions and warranty requirements.

## 1.8 WARRANTY

- A. Special Warranty: Manufacturer's standard or customized form, without monetary limitation, in which Manufacturer agrees to repair or replace components of membrane roofing system that fail in materials or workmanship within specified warranty period.
  - 1. Special warranty includes membrane roofing, base flashings, roof insulation, insulation accessories, fasteners, roofing accessories, roof walkway pads, and other components of membrane roofing system.
  - 2. Warranty Period: **Twenty years** from date of Substantial Completion.
- B. Special Project Warranty: Submit roofing Installer's warranty, on warranty form at end of this Section, signed by Installer, covering Work of this Section, including all components of membrane roofing system such as membrane roofing, base flashing, roof insulation, fasteners, and roof walkway products, for the following warranty period:
  - 1. Warranty Period: **Two years** from date of Substantial Completion.



## PART 2 - PRODUCTS

### 2.1 EPDM MEMBRANE ROOFING

- A. EPDM: ASTM D 4637, Type I, non-reinforced, uniform, flexible EPDM sheet.
  - 1. Manufacturers: Subject to compliance with requirements, provide products by one of the following:
    - a. Carlisle SynTec Incorporated.
    - b. Firestone Building Products.
    - c. Versico Incorporated.
  - 2. Thickness: **60 mils**, nominal.
  - 3. Exposed Face Color: **Black**.

### 2.2 AUXILIARY MEMBRANE ROOFING MATERIALS

- A. General: Auxiliary membrane roofing materials recommended by roofing system Manufacturer for intended use and compatible with membrane roofing.
- B. Sheet Flashing: 60-mil-thick EPDM, partially cured or cured, according to application.
- C. Bonding Adhesive: Manufacturer's standard.
- D. Seaming Material: Manufacturer's standard, synthetic-rubber polymer primer and 3-inch-wide minimum, butyl splice tape with release film.
- E. Lap Sealant: Manufacturer's standard, single-component sealant, colored to match membrane roofing.
- F. Water Cutoff Mastic: Manufacturer's standard butyl mastic sealant.
- G. Metal Termination Bars: Manufacturer's standard, predrilled stainless-steel or aluminum bars, approximately 1 by 1/8 inch thick; with anchors.
- H. Metal Battens: Manufacturer's standard, aluminum-zinc-alloy-coated or zinc-coated steel sheet, approximately 1 inch wide by 0.05 inch thick, pre-punched.
- I. Fasteners: Factory-coated steel fasteners and metal or plastic plates complying with corrosion-resistance provisions in FM Approvals 4470, designed for fastening membrane to substrate, and acceptable to roofing system Manufacturer.
- J. Miscellaneous Accessories: Provide pourable sealers, preformed cone and vent sheet flashings, preformed inside and outside corner sheet flashings, reinforced EPDM securement strips, T-joint covers, in-seam sealants, termination reglets, cover strips, and other accessories.

## 2.3 ROOF INSULATION

- A. General: Preformed roof insulation boards manufactured or approved by EPDM membrane roofing Manufacturer, selected from Manufacturer's standard sizes suitable for application, of thicknesses indicated.
- B. Polyisocyanurate Board Insulation: ASTM C 1289, Type II, Class 1, felt or glass-fiber mat facer on both major surfaces. Minimum **R-22.4** base insulation for entire roof area.
- C. Tapered Insulation: Provide factory tapered insulation boards fabricated to minimum slope of 1/4 inch per 12 inches (1/2 inch per 12 inches minimum at crickets) unless otherwise indicated. Minimum insulation base thickness at roof drains to be **4 inches, R-22.4**. Roof drain to be low point in roof. Overflow drain to be 2" higher than primary drain to limit ponding to 2" if primary drain becomes clogged. Secondary drain to be piped separately from primary drain. Secondary drain to spill to grade at a visible location with brass nozzle at wall near grade. Brass nozzle to be equal to **Zurn Z199** or **Mifab R1940** Downspout Nozzle, refer to Architectural and Plumbing Drawings.
- D. Provide preformed saddles, crickets, tapered edge strips, and other insulation shapes where indicated for sloping to drain. Fabricate to slopes indicated.

## 2.4 INSULATION ACCESSORIES

- A. General: Furnish roof insulation accessories recommended by insulation Manufacturer for intended use and compatibility with membrane roofing.
- B. Fasteners: Factory-coated steel fasteners and metal or plastic plates complying with corrosion-resistance provisions in FM Approvals 4470, designed for fastening roof insulation and cover boards to substrate, and acceptable to roofing system Manufacturer.
- C. Full Spread Applied Insulation Adhesive: Insulation Manufacturer's recommended spray applied, low rise, two component urethane adhesive formulated to attach roof insulation to substrate or to another insulation layer.
- D. Protection Mat: Woven or non-woven polypropylene, polyolefin, or polyester fabric, water permeable and resistant to UV degradation, type and weight as recommended by roofing system Manufacturer for application.

## 2.5 WALKWAYS

- A. Flexible Walkways: 24 inch x 24 inch, factory formed, nonporous, heavy duty, solid rubber, slip resistant, surface textured walkway pads, approximately 3/16 inch thick, and acceptable to membrane roofing system Manufacturer for use on adhered roofing areas. Install walkway pads at perimeter of all rooftop units and from roof access door to each piece of rooftop equipment. Refer to Roof Plan.
  - 1. Products: Subject to compliance with requirements, provide the following:
    - a. Carlisle SynTec Incorporated; Rubber walkway pads for use on adhered roof areas.

2. Color: **Black**.

## PART 3 - EXECUTION

### 3.1 EXAMINATION

- A. Examine substrates, areas, and conditions, with Installer present, for compliance with the following requirements and other conditions affecting performance of roofing system:
  1. Verify that roof openings and penetrations are in place and curbs are set and braced and that roof drain bodies are securely clamped in place.
  2. Verify that wood blocking, curbs, and nailers are securely anchored to roof deck at penetrations and terminations and that nailers match thicknesses of insulation.
  3. Verify that surface plane flatness and fastening of steel roof deck complies with requirements in Division 05 Section "Steel Decking."
  4. Verify that minimum concrete drying period recommended by roofing system Manufacturer has passed.
  5. Verify that concrete substrate is visibly dry and free of moisture. Test for capillary moisture by plastic sheet method according to ASTM D 4263.
  6. Verify that concrete curing compounds that will impair adhesion of roofing components to roof deck have been removed.
- B. Proceed with installation only after unsatisfactory conditions have been corrected.

### 3.2 PREPARATION

- A. Clean substrate of dust, debris, moisture, and other substances detrimental to roofing installation according to roofing system Manufacturer's written instructions. Remove sharp projections.
- B. Prevent materials from entering and clogging roof drains and conductors and from spilling or migrating onto surfaces of other construction. Remove roof drain plugs when no work is taking place or when rain is forecast.
- C. Complete terminations and base flashings and provide temporary seals to prevent water from entering completed sections of roofing system at the end of the workday or when rain is forecast. Remove and discard temporary seals before beginning work on adjoining roofing.

### 3.3 INSULATION INSTALLATION

- A. Coordinate installing membrane roofing system components so insulation is not exposed to precipitation or left exposed at the end of the workday.
- B. Comply with membrane roofing system and insulation Manufacturer's written instructions for installing roof insulation.
- C. Install tapered insulation under area of roofing to conform to slopes indicated.

- D. Install insulation under area of roofing to achieve required thickness. Where overall insulation thickness is 2 inches or greater, install two or more layers with joints of each succeeding layer staggered from joints of previous layer a minimum of 6 inches in each direction.
  - 1. Where installing composite and non-composite insulation in two or more layers, install non-composite board insulation for bottom layer and intermediate layers, if applicable, and install composite board insulation for top layer.
- E. Trim surface of insulation where necessary at roof drains so completed surface is flush and does not restrict flow of water.
- F. Install insulation with long joints of insulation in a continuous straight line with end joints staggered between rows, abutting edges and ends between boards. Fill gaps exceeding 1/4 inch with insulation.
  - 1. Cut and fit insulation within 1/4 inch of nailers, projections, and penetrations.
- G. Adhered Insulation: Install each layer of insulation and adhere to substrate as follows:
  - 1. Prime surface of concrete deck with asphalt primer at rate of 3/4 gal./100 sq. ft. and allow primer to dry.
  - 2. Set each layer of insulation in a uniform coverage of full-spread insulation adhesive, firmly pressing and maintaining insulation in place.

### 3.4 ADHERED MEMBRANE ROOFING INSTALLATION

- A. Adhere membrane roofing over area to receive roofing according to membrane roofing system Manufacturer's written instructions. Unroll membrane roofing and allow to relax before installing.
- B. Start installation of membrane roofing in presence of membrane roofing system Manufacturer's technical personnel.
- C. Accurately align membrane roofing and maintain uniform side and end laps of minimum dimensions required by Manufacturer. Stagger end laps.
- D. Bonding Adhesive: Apply to substrate and underside of membrane roofing at rate required by Manufacturer and allow to partially dry before installing membrane roofing. Do not apply to splice area of membrane roofing.
- E. Apply membrane roofing with side laps shingled with slope of roof deck where possible.
- F. Adhesive Seam Installation: Clean both faces of splice areas, apply splicing cement, and firmly roll side and end laps of overlapping membrane roofing according to Manufacturer's written instructions to ensure a watertight seam installation. Apply lap sealant and seal exposed edges of membrane roofing terminations.
  - 1. Apply a continuous bead of in-seam sealant before closing splice if required by membrane roofing system Manufacturer.

- G. Repair tears, voids, and lapped seams in roofing that does not comply with requirements.
- H. Spread sealant or mastic bed over deck drain flange at roof drains and securely seal membrane roofing in place with clamping ring.

### 3.5 BASE FLASHING INSTALLATION

- A. Install sheet flashings and preformed flashing accessories and adhere to substrates according to membrane roofing system Manufacturer's written instructions.
- B. Apply bonding adhesive to substrate and underside of sheet flashing at required rate and allow to partially dry. Do not apply to seam area of flashing.
- C. Flash penetrations and field-formed inside and outside corners with cured or uncured sheet flashing.
- D. Clean splice areas, apply splicing cement, and firmly roll side and end laps of overlapping sheets to ensure a watertight seam installation. Apply lap sealant and seal exposed edges of sheet flashing terminations.
- E. Terminate and seal top of sheet flashings and mechanically anchor to substrate through termination bars.

### 3.6 WALKWAY INSTALLATION

- A. Flexible Walkways: Install walkway products in locations indicated. Adhere walkway products to substrate with compatible adhesive according to roofing system Manufacturer's written instructions.

### 3.7 FIELD QUALITY CONTROL

- A. Testing Agency: **Owner will engage** a qualified independent testing agency to perform inspections.
- B. Final Roof Inspection: Arrange for roofing system Manufacturer's technical personnel to inspect roofing installation on completion.
- C. Repair or remove and replace components of membrane roofing system where inspections indicate that they do not comply with specified requirements.
- D. Additional inspections, at Contractor's expense, will be performed to determine compliance of replaced or additional work with specified requirements.

### 3.8 PROTECTING AND CLEANING

- A. Protect membrane roofing system from damage and wear during remainder of construction period. When remaining construction will not affect or endanger roofing, inspect roofing for

deterioration and damage, describing its nature and extent in a written report, with copies to Architect and Owner.

- B. Correct deficiencies in or remove membrane roofing system that does not comply with requirements, repair substrates and repair or reinstall membrane roofing system to a condition free of damage and deterioration at time of Substantial Completion and according to warranty requirements.
- C. Clean overspray and spillage from adjacent construction using cleaning agents and procedures recommended by Manufacturer of affected construction.

### 3.9 ROOFING INSTALLER'S WARRANTY

A. WHEREAS <Insert name> of <Insert address>, herein called the "Roofing Installer," has performed roofing and associated work ("work") on the following project:

- 1. Owner: <Insert name of Owner>.
- 2. Address: <Insert address>.
- 3. Building Name/Type: <Insert information>.
- 4. Address: <Insert address>.
- 5. Area of Work: <Insert information>.
- 6. Acceptance Date: <Insert date>.
- 7. Warranty Period: <Insert time>.
- 8. Expiration Date: <Insert date>.

B. AND WHEREAS Roofing Installer has contracted (either directly with Owner or indirectly as a subcontractor) to warrant said work against leaks and faulty or defective materials and workmanship for designated Warranty Period,

C. NOW THEREFORE Roofing Installer hereby warrants, subject to terms and conditions herein set forth, that during Warranty Period he will, at his own cost and expense, make or cause to be made such repairs to or replacements of said work as are necessary to correct faulty and defective work and as are necessary to maintain said work in a watertight condition.

D. This Warranty is made subject to the following terms and conditions:

- 1. Specifically excluded from this Warranty are damages to work and other parts of the building, and to building contents, caused by:
  - a. Lightning;
  - b. Peak gust wind speed exceeding 90 mph;
  - c. Fire;
  - d. Failure of roofing system substrate, including cracking, settlement, excessive deflection, deterioration, and decomposition;
  - e. Faulty construction of parapet walls, copings, chimneys, skylights, vents, equipment supports, and other edge conditions and penetrations of the work;
  - f. Vapor condensation on bottom of roofing; and
  - g. Activity on roofing by others, including construction contractors, maintenance personnel, other persons, and animals, whether authorized or unauthorized by Owner.

2. When work has been damaged by any of foregoing causes, Warranty shall be null and void until such damage has been repaired by Roofing Installer and until cost and expense thereof have been paid by Owner or by another responsible party so designated.
3. Roofing Installer is responsible for damage to work covered by this Warranty but is not liable for consequential damages to building or building contents resulting from leaks or faults or defects of work.
4. During Warranty Period, if Owner allows alteration of work by anyone other than Roofing Installer, including cutting, patching, and maintenance in connection with penetrations, attachment of other work, and positioning of anything on roof, this Warranty shall become null and void on date of said alterations, but only to the extent said alterations affect work covered by this Warranty. If Owner engages Roofing Installer to perform said alterations, Warranty shall not become null and void unless Roofing Installer, before starting said work, shall have notified Owner in writing, showing reasonable cause for claim, that said alterations would likely damage or deteriorate work, thereby reasonably justifying a limitation or termination of this Warranty.
5. During Warranty Period, if original use of roof is changed and it becomes used for, but was not originally specified for, a promenade, work deck, spray-cooled surface, flooded basin, or other use or service more severe than originally specified, this Warranty shall become null and void on date of said change, but only to the extent said change affects work covered by this Warranty.
6. Owner shall promptly notify Roofing Installer of observed, known, or suspected leaks, defects, or deterioration and shall afford reasonable opportunity for Roofing Installer to inspect work and to examine evidence of such leaks, defects, or deterioration.
7. This Warranty is recognized to be the only warranty of Roofing Installer on said work and shall not operate to restrict or cut off Owner from other remedies and resources lawfully available to Owner in cases of roofing failure. Specifically, this Warranty shall not operate to relieve Roofing Installer of responsibility for performance of original work according to requirements of the Contract Documents, regardless of whether Contract was a contract directly with Owner or a subcontract with Owner's General Contractor.

E. IN WITNESS THEREOF, this instrument has been duly executed this **<Insert day>** day of **<Insert month>**, **<Insert year>**.

1. Authorized Signature: **<Insert signature>**.
2. Name: **<Insert name>**.
3. Title: **<Insert title>**.

**\*\* END OF SECTION \*\***

**SECTION 080020**  
**ROOF SPECIALTIES**

PART 1 - GENERAL

1.1 SUMMARY

A. Section Includes:

1. Copings.
2. Reglets and counterflashings.

B. Related Requirements:

1. Section 8 "Roof Accessories" for set-on-type curbs, equipment supports, roof hatches, vents, and other manufactured roof accessory units.
2. Section 24 "Joint Sealants" for field-applied sealants between roof specialties and adjacent materials.

C. Preinstallation Conference: Conduct conference at Project site.

1. Meet with Owner and Owner's insurer if applicable, roofing-system testing and inspecting agency representative, roofing Installer, roofing-system manufacturer's representative, Installer, structural-support Installer, and installers whose work interfaces with or affects roof specialties, including installers of roofing materials and accessories.
2. Examine substrate conditions for compliance with requirements, including flatness and attachment to structural members.
3. Review special roof details, roof drainage, and condition of other construction that will affect roof specialties.

1.2 ACTION SUBMITTALS

A. Product Data: For each type of product.

1. Include construction details, material descriptions, dimensions of individual components and profiles, and finishes.

B. Shop Drawings: For roof specialties.

1. Include plans, elevations, expansion-joint locations, keyed details, and attachments to other work. Distinguish between plant- and field-assembled work.
2. Include details for expansion and contraction; locations of expansion joints, including direction of expansion and contraction.
3. Indicate profile and pattern of seams and layout of fasteners, cleats, clips, and other attachments.
4. Detail termination points and assemblies, including fixed points.
5. Include details of special conditions.



- C. Samples: For each type of roof specialty and for each color and texture specified.
- D. Samples for Verification:
  - 1. Include Samples of each type of roof specialty to verify finish and color selection, in manufacturer's standard sizes.
  - 2. Include copings and reglets and counterflashings made from 12-inch lengths of full-size components in specified material, and including fasteners, cover joints, accessories, and attachments.

### 1.3 INFORMATIONAL SUBMITTALS

- A. Qualification Data: For manufacturer.
- B. Product Certificates: For each type of roof specialty.
- C. Product Test Reports: For copings, for tests performed by a qualified testing agency.
- D. Sample Warranty: For manufacturer's special warranty.

### 1.4 CLOSEOUT SUBMITTALS

- A. Maintenance Data: For roofing specialties to include in maintenance manuals.

### 1.5 QUALITY ASSURANCE

- A. Manufacturer Qualifications: A qualified manufacturer offering products meeting requirements that are FM Approvals listed for specified class and SPRI ES-1 tested to specified design pressure.
- B. Source Limitations: Obtain roof specialties approved by manufacturer providing roofing-system warranty specified in Section 8 "Ethylene Propylene Diene Monomer (EPDM)".
- C. Mockups: Build mockups to verify selections made under Sample submittals, to demonstrate aesthetic effects, and set quality standards for fabrication and installation.
  - 1. Build mockup of typical coping as shown on Drawings.
  - 2. Approval of mockups does not constitute approval of deviations from the Contract Documents contained in mockups unless Owner specifically approves such deviations in writing.
  - 3. Subject to compliance with requirements, approved mockups may become part of the completed Work if undisturbed at time of Substantial Completion.

### 1.6 DELIVERY, STORAGE, AND HANDLING

- A. Do not store roof specialties in contact with other materials that might cause staining, denting, or other surface damage. Store roof specialties away from uncured concrete and masonry.

- B. Protect strippable protective covering on roof specialties from exposure to sunlight and high humidity, except to extent necessary for the period of roof-specialty installation.

## 1.7 FIELD CONDITIONS

- A. Field Measurements: Verify profiles and tolerances of roof-specialty substrates by field measurements before fabrication, and indicate measurements on Shop Drawings.
- B. Coordination: Coordinate roof specialties with flashing, trim, and construction of parapets, roof deck, roof and wall panels, and other adjoining work to provide a leakproof, secure, and noncorrosive installation.

## 1.8 WARRANTY

- A. Roofing-System Warranty: Roof specialties are included in warranty provisions in Section 8 "Ethylene Propylene Diene Monomer (EPDM)".
- B. Special Warranty on Painted Finishes: Manufacturer agrees to repair finish or replace roof specialties that show evidence of deterioration of factory-applied finishes within specified warranty period.
  - 1. Fluoropolymer Finish: Deterioration includes, but is not limited to, the following:
    - a. Color fading more than 5 Hunter units when tested according to ASTM D 2244.
    - b. Chalking in excess of a No. 8 rating when tested according to ASTM D 4214.
    - c. Cracking, checking, peeling, or failure of paint to adhere to bare metal.
  - 2. Finish Warranty Period: 20 years from date of Substantial Completion.

## PART 2 - PRODUCTS

### 2.1 PERFORMANCE REQUIREMENTS

- A. General Performance: Roof specialties shall withstand exposure to weather and resist thermally induced movement without failure, rattling, leaking, or fastener disengagement due to defective manufacture, fabrication, installation, or other defects in construction.
- B. FM Approvals' Listing: Manufacture and install copings that are listed in FM Approvals' "RoofNav" and approved for windstorm classification, Class 1-90. Identify materials with FM Approvals' markings.
- C. SPRI Wind Design Standard: Manufacture and install copings tested according to SPRI ES-1 and capable of resisting the following design pressures:
  - 1. Design Pressure: As indicated on Drawings.
- D. Thermal Movements: Allow for thermal movements from ambient and surface temperature changes to prevent buckling, opening of joints, hole elongation, overstressing of components,

failure of joint sealants, failure of connections, and other detrimental effects. Provide clips that resist rotation and avoid shear stress as a result of thermal movements. Base calculations on surface temperatures of materials due to both solar heat gain and nighttime-sky heat loss.

1. Temperature Change (Range): 120 deg F, ambient; 180 deg F, material surfaces.

## 2.2 COPINGS

- A. Metal Copings: Manufactured coping system consisting of metal coping cap in section lengths not exceeding 12 feet, concealed anchorage; with corner units, end cap units, and concealed splice plates with finish matching coping caps.

1. Manufacturers: Subject to compliance with requirements, available manufacturers offering products that may be incorporated into the Work include, but are not limited to, the following:

- a. Architectural Products Company.
- b. ATAS International, Inc.
- c. Castle Metal Products.
- d. Cheney Flashing Company.
- e. Hickman Company, W. P.
- f. Merchant & Evans, Inc.
- g. Metal-Era, Inc.
- h. Metal-Fab Manufacturing, LLC.
- i. Perimeter Systems; a division of Southern Aluminum Finishing Company, Inc.
- j. Petersen Aluminum Corporation.

2. Formed Aluminum Sheet Coping Caps: Aluminum sheet, 0.050 inch thick.

- a. Surface: Smooth, flat finish.
- b. Finish: Two-coat fluoropolymer.
- c. Color: As **selected by Owner** from manufacturer's full range.

3. Corners: Factory mitered and mechanically clinched and sealed watertight.
4. Coping-Cap Attachment Method: Face leg hooked to continuous cleat, fabricated from coping-cap material.

- a. Face-Leg Cleats: Concealed, continuous galvanized-steel sheet.

## 2.3 REGLETS AND COUNTERFLASHINGS

- A. Manufacturers: Subject to compliance with requirements, available manufacturers offering products that may be incorporated into the Work include, but are not limited to, the following:

1. Castle Metal Products.
2. Cheney Flashing Company.
3. Fry Reglet Corporation.
4. Heckmann Building Products Inc.
5. Hickman Company, W. P.

6. Keystone Flashing Company, Inc.
  7. Metal-Era, Inc.
  8. Metal-Fab Manufacturing, LLC.
- B. Reglets: Manufactured units formed to provide secure interlocking of separate reglet and counterflashing pieces, from the following exposed metal:
1. Formed Aluminum: 0.050 inch thick.
  2. Corners: Factory mitered and continuously welded.
  3. Masonry Type, Embedded: Provide reglets with offset top flange for embedment in masonry mortar joint.
  4. Multiuse Type, Embedded: For multiuse embedment in cast-in-place concrete and masonry mortar joints.
- C. Counterflashings: Manufactured units of heights to overlap top edges of base flashings by 4 inches and in lengths not exceeding 12 feet designed to snap into reglets and compress against base flashings with joints lapped, from the following exposed metal:
1. Formed Aluminum: 0.032 inch thick.
- D. Accessories:
1. Flexible-Flashing Retainer: Provide resilient plastic or rubber accessory to secure flexible flashing in reglet where clearance does not permit use of standard metal counterflashing or where reglet is provided separate from metal counterflashing.
  2. Counterflashing Wind-Restraint Clips: Provide clips to be installed before counterflashing to prevent wind uplift of counterflashing lower edge.
- E. Aluminum Finish: Two-coat fluoropolymer.
1. Color: As **selected by Owner** from manufacturer's full range.

## 2.4 MATERIALS

- A. Aluminum Sheet: ASTM B 209, alloy as standard with manufacturer for finish required, with temper to suit forming operations and performance required.

## 2.5 UNDERLAYMENT MATERIALS

- A. Self-Adhering, High-Temperature Sheet: Minimum 30 to 40 mils thick, consisting of slip-resisting polyethylene-film top surface laminated to layer of butyl or SBS-modified asphalt adhesive, with release-paper backing; cold applied. Provide primer when recommended by underlayment manufacturer.
1. Thermal Stability: ASTM D 1970; stable after testing at 240 deg F.
  2. Low-Temperature Flexibility: ASTM D 1970; passes after testing at minus 20 deg F.
  3. Products: Subject to compliance with requirements, available products that may be incorporated into the Work include, but are not limited to, the following:
    - a. Carlisle Coatings & Waterproofing; CCW WIP 300HT.

- b. Grace Construction Products, a unit of W. R. Grace & Co.; Grace Ice and Water Shield HT.
  - c. Henry Company; Blueskin PE200 HT.
  - d. Metal-Fab Manufacturing, LLC; MetShield.
  - e. Owens Corning; WeatherLock Metal High Temperature Underlayment.
- B. Felt: ASTM D 226, Type II (No. 30), asphalt-saturated organic felt, nonperforated.
  - C. Slip Sheet: Rosin-sized building paper, 3-lb/100 sq. ft. minimum.

## 2.6 MISCELLANEOUS MATERIALS

- A. Fasteners: Manufacturer's recommended fasteners, suitable for application and designed to meet performance requirements. Furnish the following unless otherwise indicated:
  - 1. Fasteners for Aluminum: Aluminum or Series 300 stainless steel.
- B. Elastomeric Sealant: ASTM C 920, elastomeric silicone polymer sealant of type, grade, class, and use classifications required by roofing-specialty manufacturer for each application.
- C. Butyl Sealant: ASTM C 1311, single-component, solvent-release butyl rubber sealant; polyisobutylene plasticized; heavy bodied for hooked-type joints with limited movement.
- D. Bituminous Coating: Cold-applied asphalt emulsion complying with ASTM D 1187.
- E. Asphalt Roofing Cement: ASTM D 4586, asbestos free, of consistency required for application.

## 2.7 FINISHES

- A. Comply with NAAMM's "Metal Finishes Manual for Architectural and Metal Products" for recommendations for applying and designating finishes.
- B. Protect mechanical and painted finishes on exposed surfaces from damage by applying a strippable, temporary protective covering before shipping.
- C. Appearance of Finished Work: Noticeable variations in same piece are unacceptable. Variations in appearance of adjoining components are acceptable if they are within the range of approved Samples and are assembled or installed to minimize contrast.
- D. Coil-Coated Aluminum Sheet Finishes:
  - 1. High-Performance Organic Finish: Prepare, pretreat, and apply coating to exposed metal surfaces to comply with coating and resin manufacturers' written instructions.
    - a. Two-Coat Fluoropolymer: AAMA 2605. Fluoropolymer finish containing not less than 70 percent PVDF resin by weight in color coat. Prepare, pretreat, and apply coating to exposed metal surfaces to comply with coating and resin manufacturers' written instructions.

## PART 3 - EXECUTION

### 3.1 EXAMINATION

- A. Examine substrates, areas, and conditions, with Installer present, to verify actual locations, dimensions, and other conditions affecting performance of the Work.
- B. Examine walls, roof edges, and parapets for suitable conditions for roof specialties.
- C. Verify that substrate is sound, dry, smooth, clean, sloped for drainage where applicable, and securely anchored.
- D. Proceed with installation only after unsatisfactory conditions have been corrected.

### 3.2 UNDERLAYMENT INSTALLATION

- A. Self-Adhering Sheet Underlayment: Apply primer if required by manufacturer. Comply with temperature restrictions of underlayment manufacturer for installation. Apply wrinkle free, in shingle fashion to shed water, and with end laps of not less than 6 inches staggered 24 inches between courses. Overlap side edges not less than 3-1/2 inches. Roll laps with roller. Cover underlayment within 14 days.
  - 1. Apply continuously under copings and reglets and counterflashings.
  - 2. Coordinate application of self-adhering sheet underlayment under roof specialties with requirements for continuity with adjacent air barrier materials.
- B. Felt Underlayment: Install with adhesive for temporary anchorage to minimize use of mechanical fasteners under roof specialties. Apply in shingle fashion to shed water, with lapped joints of not less than 2 inches.
- C. Slip Sheet: Install with tape or adhesive for temporary anchorage to minimize use of mechanical fasteners under roof specialties. Apply in shingle fashion to shed water, with lapped joints of not less than 2 inches.

### 3.3 INSTALLATION, GENERAL

- A. General: Install roof specialties according to manufacturer's written instructions. Anchor roof specialties securely in place, with provisions for thermal and structural movement. Use fasteners, solder, protective coatings, separators, underlayments, sealants, and other miscellaneous items as required to complete roof-specialty systems.
  - 1. Install roof specialties level, plumb, true to line and elevation; with limited oil-canning and without warping, jogs in alignment, buckling, or tool marks.
  - 2. Provide uniform, neat seams with minimum exposure of solder and sealant.
  - 3. Install roof specialties to fit substrates and to result in weathertight performance. Verify shapes and dimensions of surfaces to be covered before manufacture.
  - 4. Torch cutting of roof specialties is not permitted.
  - 5. Do not use graphite pencils to mark metal surfaces.

- B. Metal Protection: Protect metals against galvanic action by separating dissimilar metals from contact with each other or with corrosive substrates by painting contact surfaces with bituminous coating or by other permanent separation as recommended by manufacturer.
  - 1. Coat concealed side of uncoated aluminum roof specialties with bituminous coating where in contact with wood, ferrous metal, or cementitious construction.
  - 2. Bed flanges in thick coat of asphalt roofing cement where required by manufacturers of roof specialties for waterproof performance.
- C. Expansion Provisions: Allow for thermal expansion of exposed roof specialties.
  - 1. Space movement joints at a maximum of 12 feet with no joints within 18 inches of corners or intersections unless otherwise indicated on Drawings.
  - 2. When ambient temperature at time of installation is between 40 and 70 deg F, set joint members for 50 percent movement each way. Adjust setting proportionately for installation at higher ambient temperatures.
- D. Fastener Sizes: Use fasteners of sizes that penetrate substrate not less than recommended by fastener manufacturer to achieve maximum pull-out resistance.
- E. Seal concealed joints with butyl sealant as required by roofing-specialty manufacturer.
- F. Seal joints as required for weathertight construction. Place sealant to be completely concealed in joint. Do not install sealants at temperatures below 40 deg F.

### 3.4 COPING INSTALLATION

- A. Install cleats, anchor plates, and other anchoring and attachment accessories and devices with concealed fasteners.
- B. Anchor copings with manufacturer's required devices, fasteners, and fastener spacing to meet performance requirements.
  - 1. Interlock face-leg drip edge into continuous cleat anchored to substrate at 16-inch centers or manufacturer's required spacing that meets performance requirements. Anchor back leg of coping with screw fasteners and elastomeric washers at 16-inch centers or manufacturer's required spacing that meets performance requirements.

### 3.5 REGLET AND COUNTERFLASHING INSTALLATION

- A. General: Coordinate installation of reglets and counterflashings with installation of base flashings.
- B. Embedded Reglets: See Section 24 "Cast-in-Place Concrete" and Section 24 "Unit Masonry" for installation of reglets.
- C. Surface-Mounted Reglets: Install reglets to receive flashings where flashing without embedded reglets is indicated on Drawings. Install at height so that inserted counterflashings overlap 4 inches over top edge of base flashings.

- D. Counterflashings: Insert counterflashings into reglets or other indicated receivers; ensure that counterflashings overlap 4 inches over top edge of base flashings. Lap counterflashing joints a minimum of 4 inches and bed with butyl sealant. Fit counterflashings tightly to base flashings.

### 3.6 CLEANING AND PROTECTION

- A. Clean exposed metal surfaces of substances that interfere with uniform oxidation and weathering.
- B. Clean and neutralize flux materials. Clean off excess solder and sealants.
- C. Remove temporary protective coverings and strippable films as roof specialties are installed. On completion of installation, clean finished surfaces, including removing unused fasteners, metal filings, pop rivet stems, and pieces of flashing. Maintain roof specialties in a clean condition during construction.
- D. Replace roof specialties that have been damaged or that cannot be successfully repaired by finish touchup or similar minor repair procedures.

\*\* END OF SECTION \*\*



**SECTION 080030**  
**ROOF ACCESSORIES**

PART 1 - GENERAL

1.1 SUMMARY

A. Section Includes:

1. Roof curbs.
2. Equipment supports.
3. Preformed flashing sleeves.

B. Related Sections:

1. Section 6 "Roof Specialties" for manufactured copings, reglets, and counterflashing.

1.2 PERFORMANCE REQUIREMENTS

- A. General Performance: Roof accessories shall withstand exposure to weather and resist thermally induced movement without failure, rattling, leaking, or fastener disengagement due to defective manufacture, fabrication, installation, or other defects in construction.

1.3 ACTION SUBMITTALS

- A. Product Data: For each type of roof accessory indicated. Include construction details, material descriptions, dimensions of individual components and profiles, and finishes.
- B. Shop Drawings: For roof accessories. Include plans, elevations, keyed details, and attachments to other work. Indicate dimensions, loadings, and special conditions. Distinguish between plant- and field-assembled work.
- C. Samples: For each exposed product and for each color and texture specified, prepared on Samples of size to adequately show color.

1.4 INFORMATIONAL SUBMITTALS

- A. Coordination Drawings: Roof plans, drawn to scale, and coordinating penetrations and roof-mounted items. Show the following:
1. Size and location of roof accessories specified in this Section.
  2. Method of attaching roof accessories to roof or building structure.
  3. Other roof-mounted items including mechanical and electrical equipment, ductwork, piping, and conduit.
  4. Required clearances.
- B. Warranty: Sample of special warranty.

## 1.5 CLOSEOUT SUBMITTALS

- A. Operation and Maintenance Data: For roof accessories to include in operation and maintenance manuals.

## 1.6 COORDINATION

- A. Coordinate layout and installation of roof accessories with roofing membrane and base flashing and interfacing and adjoining construction to provide a leakproof, weathertight, secure, and noncorrosive installation.
- B. Coordinate dimensions with rough-in information or Shop Drawings of equipment to be supported.

## 1.7 WARRANTY

- A. Special Warranty on Painted Finishes: Manufacturer's standard form in which manufacturer agrees to repair finishes or replace roof accessories that show evidence of deterioration of factory-applied finishes within specified warranty period.
  - 1. Fluoropolymer Finish: Deterioration includes, but is not limited to, the following:
    - a. Color fading more than 5 Hunter units when tested according to ASTM D 2244.
    - b. Chalking in excess of a No. 8 rating when tested according to ASTM D 4214.
    - c. Cracking, checking, peeling, or failure of paint to adhere to bare metal.
  - 2. Finish Warranty Period: 20 years from date of Substantial Completion.

## PART 2 - PRODUCTS

### 2.1 METAL MATERIALS

- A. Zinc-Coated (Galvanized) Steel Sheet: ASTM A 653, G90 (Z275) coating designation.
  - 1. Exposed Coil-Coated Finish: Prepainted by the coil-coating process to comply with ASTM A 755/A 755M. Prepare, pretreat, and apply coating to exposed metal surfaces to comply with coating and resin manufacturers' written instructions.
    - a. Two-Coat Fluoropolymer Finish: AAMA 621. System consisting of primer and fluoropolymer color topcoat containing not less than 70 percent PVDF resin by weight.
  - 2. Concealed Finish: Pretreat with manufacturer's standard white or light-colored acrylic or polyester-backer finish consisting of prime coat and wash coat, with a minimum total dry film thickness of 0.5 mil.
- B. Aluminum Sheet: ASTM B 209, manufacturer's standard alloy for finish required, with temper to suit forming operations and performance required.

1. Exposed Coil-Coated Finish: Prepare, pretreat, and apply coating to exposed metal surfaces to comply with coating and resin manufacturers' written instructions.
    - a. Two-Coat Fluoropolymer Finish: AAMA 620. System consisting of primer and fluoropolymer color topcoat containing not less than 70 percent PVDF resin by weight.
  2. Concealed Finish: Pretreat with manufacturer's standard white or light-colored acrylic or polyester-backer finish consisting of prime coat and wash coat, with a minimum total dry film thickness of 0.5 mil.
- C. Aluminum Extrusions and Tubes: ASTM B 221, manufacturer's standard alloy and temper for type of use, finished to match assembly where used, otherwise mill finished.
- D. Copper Sheet: ASTM B 370, manufacturer's standard temper.
- E. Stainless-Steel Sheet and Shapes: ASTM A 240 or ASTM A 666, Type 304.
- F. Steel Shapes: ASTM A 36, hot-dip galvanized according to ASTM A 123 unless otherwise indicated.
- G. Steel Tube: ASTM A 500, round tube.
- H. Galvanized-Steel Tube: ASTM A 500, round tube, hot-dip galvanized according to ASTM A 123.
- I. Steel Pipe: ASTM A 53, galvanized.

## 2.2 MISCELLANEOUS MATERIALS

- A. General: Provide materials and types of fasteners, protective coatings, sealants, and other miscellaneous items required by manufacturer for a complete installation.
- B. Polyisocyanurate Board Insulation: ASTM C 1289, thickness as indicated.
- C. Wood Nailers: Softwood lumber, pressure treated with waterborne preservatives for aboveground use, acceptable to authorities having jurisdiction, containing no arsenic or chromium, and complying with AWWA C2; not less than 1-1/2 inches thick.
- D. Security Grilles: 3/4-inch diameter, ASTM A 1011 steel bars spaced 6 inches o.c. in one direction and 12 inches o.c. in the other; factory finished as follows:
  1. Surface Preparation: Remove mill scale and rust, if any, from uncoated steel, complying with SSPC-SP 5/NACE No. 1, "White Metal Blast Cleaning," or SSPC-SP 8, "Pickling."
  2. Factory Priming for Field-Painted Finish: Apply shop primer specified below immediately after surface preparation and pretreatment.
  3. Shop Primer: Manufacturer's or fabricator's standard, fast-curing, lead- and chromate-free, universal primer; selected for resistance to normal atmospheric corrosion, for compatibility with substrate and field-applied finish paint system indicated, and for capability to provide a sound foundation for field-applied topcoats under prolonged exposure.

- E. Bituminous Coating: Cold-applied asphalt emulsion complying with ASTM D 1187.
- F. Underlayment:
  - 1. Felt: ASTM D 226, Type II (No. 30), asphalt-saturated organic felt, nonperforated.
  - 2. Polyethylene Sheet: 6-mil- thick polyethylene sheet complying with ASTM D 4397.
  - 3. Slip Sheet: Building paper, 3-lb/100 sq. ft. minimum, rosin sized.
- G. Fasteners: Roof accessory manufacturer's recommended fasteners suitable for application and metals being fastened. Match finish of exposed fasteners with finish of material being fastened. Provide nonremovable fastener heads to exterior exposed fasteners. Furnish the following unless otherwise indicated:
  - 1. Fasteners for Zinc-Coated or Aluminum-Zinc Alloy-Coated Steel: Series 300 stainless steel or hot-dip zinc-coated steel according to ASTM A 153 or ASTM F 2329.
  - 2. Fasteners for Aluminum Sheet: Aluminum or Series 300 stainless steel.
  - 3. Fasteners for Copper Sheet: Copper, hardware bronze, or passivated Series 300 stainless steel.
  - 4. Fasteners for Stainless-Steel Sheet: Series 300 stainless steel.
- H. Gaskets: Manufacturer's standard tubular or fingered design of neoprene, EPDM, PVC, or silicone or a flat design of foam rubber, sponge neoprene, or cork.
- I. Elastomeric Sealant: ASTM C 920, elastomeric silicone polymer sealant as recommended by roof accessory manufacturer for installation indicated; low modulus; of type, grade, class, and use classifications required to seal joints and remain watertight.
- J. Butyl Sealant: ASTM C 1311, single-component, solvent-release butyl rubber sealant; polyisobutylene plasticized; heavy bodied for expansion joints with limited movement.
- K. Asphalt Roofing Cement: ASTM D 4586, asbestos free, of consistency required for application.

## 2.3 ROOF CURBS

- A. Roof Curbs: Internally reinforced roof-curb units with integral spring-type vibration isolators and capable of supporting superimposed live and dead loads, including equipment loads and other construction indicated on Drawings; with welded or mechanically fastened and sealed corner joints, stepped integral metal cant raised the thickness of roof insulation, and integrally formed deck-mounting flange at perimeter bottom.
  - 1. Manufacturers: Subject to compliance with requirements, available manufacturers offering products that may be incorporated into the Work include, but are not limited to, the following:
    - a. AES Industries, Inc.
    - b. Curbs Plus, Inc.
    - c. Custom Solution Roof and Metal Products.
    - d. Greenheck Fan Corporation.
    - e. LM Curbs.
    - f. Metallic Products Corp.

- g. Milcor Inc.; Commercial Products Group of Hart & Cooley, Inc.
  - h. Pate Company (The).
  - i. Roof Products, Inc.
  - j. Safe Air of Illinois.
  - k. Thybar Corporation.
  - l. Vent Products Co., Inc.
- B. Size: Coordinate dimensions with roughing-in information or Shop Drawings of equipment to be supported.
- C. Loads: Refer to Mechanical drawings.
- D. Material: Zinc-coated (galvanized) or Aluminum-zinc alloy-coated steel sheet, 0.079 inch thick.
- 1. Finish: Two-coat fluoropolymer.
  - 2. Color: As **selected by Owner** from manufacturer's full range.
- E. Material: Aluminum sheet, 0.090 inch thick.
- 1. Finish: Two-coat fluoropolymer.
  - 2. Color: As **selected by Owner** from manufacturer's full range.
- F. Material: Stainless-steel sheet, 0.078 inch thick.
- 1. Finish: Manufacturer's standard.
- G. Construction:
- 1. Insulation: Factory insulated with 1-1/2-inch-thick polyisocyanurate board insulation.
  - 2. Liner: Same material as curb, of manufacturer's standard thickness and finish.
  - 3. Factory-installed wood nailer at top of curb, continuous around curb perimeter.
  - 4. On ribbed or fluted metal roofs, form deck-mounting flange at perimeter bottom to conform to roof profile.
  - 5. Fabricate curbs to minimum height of 12 inches above insulation height unless otherwise indicated.
  - 6. Top Surface: Level around perimeter with roof slope accommodated by sloping the deck-mounting flange.
  - 7. Sloping Roofs: Where roof slope exceeds 1:48, fabricate curb with perimeter curb height tapered to accommodate roof slope so that top surface of perimeter curb is level. Equip unit with water diverter or cricket on side that obstructs water flow.
  - 8. Security Grille: Provide at roof openings.

## 2.4 EQUIPMENT SUPPORTS

- A. Equipment Supports: Internally reinforced metal equipment supports capable of supporting superimposed live and dead loads, including equipment loads and other construction indicated on Drawings; with welded or mechanically fastened and sealed corner joints, stepped integral metal cant raised the thickness of roof insulation, and integrally formed deck-mounting flange at perimeter bottom.

1. Manufacturers: Subject to compliance with requirements, available manufacturers offering products that may be incorporated into the Work include, but are not limited to, the following:
  - a. AES Industries, Inc.
  - b. Curbs Plus, Inc.
  - c. Custom Solution Roof and Metal Products.
  - d. Greenheck Fan Corporation.
  - e. LM Curbs.
  - f. Milcor Inc.; Commercial Products Group of Hart & Cooley, Inc.
  - g. Pate Company (The).
  - h. Roof Products, Inc.
  - i. Thybar Corporation.
  - j. Vent Products Co., Inc.
  
- B. Size: Coordinate dimensions with roughing-in information or Shop Drawings of equipment to be supported.
  
- C. Loads: Refer to Mechanical drawings.
  
- D. Material: Zinc-coated (galvanized) or Aluminum-zinc alloy-coated steel sheet, 0.079 inch thick.
  1. Finish: Two-coat fluoropolymer.
  2. Color: As **selected by Owner** from manufacturer's full range.
  
- E. Material: Aluminum sheet, 0.090 inch thick.
  1. Finish: Two-coat fluoropolymer.
  2. Color: As **selected by Owner** from manufacturer's full range.
  
- F. Material: Stainless-steel sheet, 0.078 inch thick.
  1. Finish: Manufacturer's standard.
  
- G. Construction:
  1. Insulation: Factory insulated with 1-1/2-inch-thick polyisocyanurate board insulation.
  2. Liner: Same material as equipment support, of manufacturer's standard thickness and finish.
  3. Factory-installed continuous wood nailers 5-1/2 inches wide at tops of equipment supports.
  4. Metal Counterflashing: Manufacturer's standard, removable, fabricated of same metal and finish as equipment support.
  5. Fabricate equipment supports to minimum height of 12 inches above insulation height unless otherwise indicated.
  6. Sloping Roofs: Where roof slope exceeds 1:48, fabricate each support with height to accommodate roof slope so that tops of supports are level with each other. Equip supports with water diverters or crickets on sides that obstruct water flow.
  7. Security Grille: Provide at roof openings.

## 2.5 PREFORMED FLASHING SLEEVES

- A. Exhaust Vent Flashing: Double-walled metal flashing sleeve or boot, insulation filled, with integral deck flange, 12 inches above roof insulation high, with removable metal hood and slotted metal collar.
  - 1. Manufacturers: Subject to compliance with requirements, available manufacturers offering products that may be incorporated into the Work include, but are not limited to, the following:
    - a. Custom Solution Roof and Metal Products.
    - b. Thaler Metal USA Inc.
  - 2. Metal: Aluminum sheet, 0.063 inch thick.
  - 3. Diameter: As required for application.
  - 4. Finish: Manufacturer's standard.
- B. Vent Stack Flashing: Metal flashing sleeve, uninsulated, with integral deck flange.
  - 1. Manufacturers: Subject to compliance with requirements, available manufacturers offering products that may be incorporated into the Work include, but are not limited to, the following:
    - a. Custom Solution Roof and Metal Products.
    - b. Milcor Inc.; Commercial Products Group of Hart & Cooley, Inc.
    - c. Thaler Metal USA Inc.
  - 2. Metal: Aluminum sheet, 0.063 inch thick.
  - 3. Height: 19 inches.
  - 4. Diameter: As required for application.
  - 5. Finish: Manufacturer's standard.

## 2.6 GENERAL FINISH REQUIREMENTS

- A. Comply with NAAMM's "Metal Finishes Manual for Architectural and Metal Products" for recommendations for applying and designating finishes.
- B. Appearance of Finished Work: Noticeable variations in same piece are not acceptable. Variations in appearance of adjoining components are acceptable if they are within the range of approved Samples and are assembled or installed to minimize contrast.

## PART 3 - EXECUTION

### 3.1 EXAMINATION

- A. Examine substrates, areas, and conditions, with Installer present, to verify actual locations, dimensions, and other conditions affecting performance of the Work.
- B. Verify that substrate is sound, dry, smooth, clean, sloped for drainage, and securely anchored.

- C. Verify dimensions of roof openings for roof accessories.
- D. Proceed with installation only after unsatisfactory conditions have been corrected.

### 3.2 INSTALLATION

- A. General: Install roof accessories according to manufacturer's written instructions.
  - 1. Install roof accessories level, plumb, true to line and elevation, and without warping, jogs in alignment, excessive oil canning, buckling, or tool marks.
  - 2. Anchor roof accessories securely in place so they are capable of resisting indicated loads.
  - 3. Use fasteners, separators, sealants, and other miscellaneous items as required to complete installation of roof accessories and fit them to substrates.
  - 4. Install roof accessories to resist exposure to weather without failing, rattling, leaking, or loosening of fasteners and seals.
- B. Metal Protection: Protect metals against galvanic action by separating dissimilar metals from contact with each other or with corrosive substrates by painting contact surfaces with bituminous coating or by other permanent separation as recommended by manufacturer.
  - 1. Coat concealed side of uncoated aluminum or stainless-steel roof accessories with bituminous coating where in contact with wood, ferrous metal, or cementitious construction.
  - 2. Underlayment: Where installing roof accessories directly on cementitious or wood substrates, install a course of felt underlayment and cover with a slip sheet, or install a course of polyethylene sheet.
  - 3. Bed flanges in thick coat of asphalt roofing cement where required by manufacturers of roof accessories for waterproof performance.
- C. Roof Curb Installation: Install each roof curb so top surface is level.
- D. Equipment Support Installation: Install equipment supports so top surfaces are level with each other.
- E. Security Grilles: Weld bar intersections and, using tamper-resistant bolts, attach the ends of bars to structural frame or primary curb walls.
- F. Preformed Flashing-Sleeve Installation: Secure flashing sleeve to roof membrane according to flashing-sleeve manufacturer's written instructions.
- G. Seal joints with elastomeric or butyl sealant as required by roof accessory manufacturer.

### 3.3 REPAIR AND CLEANING

- A. Galvanized Surfaces: Clean field welds, bolted connections, and abraded areas and repair galvanizing according to ASTM A 780.
- B. Touch up factory-primed surfaces with compatible primer ready for field painting according to Section 24 "Exterior Painting" and "Interior Painting."



- C. Clean exposed surfaces according to manufacturer's written instructions.
- D. Clean off excess sealants.
- E. Replace roof accessories that have been damaged or that cannot be successfully repaired by finish touchup or similar minor repair procedures.

\*\* END OF SECTION \*\*

**SECTION 100010  
HOLLOW METAL DOORS AND FRAMES**

**PART 1 - GENERAL**

**1.1 SUMMARY**

- A. Section includes hollow-metal work.
- B. Related Requirements:
  - 1. Section 10 "Door Hardware" for door hardware for hollow-metal doors.

**1.2 DEFINITIONS**

- A. Minimum Thickness: Minimum thickness of base metal without coatings according to NAAMM-HMMA 803 or SDI A250.8.

**1.3 COORDINATION**

- A. Coordinate anchorage installation for hollow-metal frames. Furnish setting drawings, templates, and directions for installing anchorages, including sleeves, concrete inserts, anchor bolts, and items with integral anchors. Deliver such items to Project site in time for installation.

**1.4 PREINSTALLATION MEETINGS**

- A. Preinstallation Conference: Conduct conference at Project site.

**1.5 ACTION SUBMITTALS**

- A. Product Data: For each type of product.
  - 1. Include construction details, material descriptions, core descriptions, fire-resistance ratings, temperature-rise ratings, and finishes.
- B. Shop Drawings: Include the following:
  - 1. Elevations of each door type.
  - 2. Details of doors, including vertical- and horizontal-edge details and metal thicknesses.
  - 3. Frame details for each frame type, including dimensioned profiles and metal thicknesses.
  - 4. Locations of reinforcement and preparations for hardware.
  - 5. Details of each different wall opening condition.
  - 6. Details of anchorages, joints, field splices, and connections.
  - 7. Details of accessories.
  - 8. Details of moldings, removable stops, and glazing.
  - 9. Details of conduit and preparations for power, signal, and control systems.

C. Samples for Verification:

1. For each type of exposed finish required, prepared on Samples of not less than 3 by 5 inches.
2. For "Doors" and "Frames" subparagraphs below, prepare Samples approximately 12 by 12 inches to demonstrate compliance with requirements for quality of materials and construction:
  - a. Doors: Show vertical-edge, top, and bottom construction; core construction; and hinge and other applied hardware reinforcement. Include separate section showing glazing if applicable.
  - b. Frames: Show profile, corner joint, floor and wall anchors, and silencers. Include separate section showing fixed hollow-metal panels and glazing if applicable.

D. Schedule: Provide a schedule of hollow-metal work prepared by or under the supervision of supplier, using same reference numbers for details and openings as those on Drawings. Coordinate with final Door Hardware Schedule.

1.6 INFORMATIONAL SUBMITTALS

- A. Product Test Reports: For each type of hollow-metal door and frame assembly, for tests performed by a qualified testing agency.
- B. Oversize Construction Certification: For assemblies required to be fire rated and exceeding limitations of labeled assemblies.

1.7 DELIVERY, STORAGE, AND HANDLING

- A. Deliver hollow-metal work palletized, packaged, or crated to provide protection during transit and Project-site storage. Do not use nonvented plastic.
  1. Provide additional protection to prevent damage to factory-finished units.
- B. Deliver welded frames with two removable spreader bars across bottom of frames, tack welded to jambs and mullions.
- C. Store hollow-metal work vertically under cover at Project site with head up. Place on minimum 4-inch high wood blocking. Provide minimum 1/4-inch space between each stacked door to permit air circulation.

PART 2 - PRODUCTS

2.1 MANUFACTURERS

- A. Manufacturers: Subject to compliance with requirements, available manufacturers offering products that may be incorporated into the Work include, but are not limited to, the following:
  1. Amweld International, LLC.

2. Apex Industries, Inc.
3. Ceco Door Products; an Assa Abloy Group company.
4. Commercial Door & Hardware Inc.
5. Concept Frames, Inc.
6. Curries Company; an Assa Abloy Group company.
7. Custom Metal Products.
8. Daybar.
9. Deansteel.
10. de La Fontaine Industries.
11. DKS Steel Door & Frame Sys. Inc.
12. Door Components, Inc.
13. Fleming-Baron Door Products.
14. Gensteel Doors Inc.
15. Greensteel Industries, Ltd.
16. HMF Express.
17. Hollow Metal Inc.
18. Hollow Metal Xpress.
19. J/R Metal Frames Manufacturing, Inc.
20. Karpen Steel Custom Doors & Frames.
21. L.I.F. Industries, Inc.
22. LaForce, Inc.
23. Megamet Industries, Inc.
24. Mesker Door Inc.
25. Michbi Doors Inc.
26. MPI Group, LLC (The).
27. National Custom Hollow Metal.
28. North American Door Corp.
29. Philipp Manufacturing Co (The).
30. Pioneer Industries, Inc.
31. Premier Products, Inc.
32. Republic Doors and Frames.
33. Rocky Mountain Metals, Inc.
34. Security Metal Products Corp.
35. Shanahans Manufacturing Ltd.
36. Steelcraft; an Ingersoll-Rand company.
37. Steward Steel; Door Division.
38. Stiles Custom Metal, Inc.
39. Titan Metal Products, Inc.
40. Trillium Steel Doors Limited.
41. West Central Mfg. Inc.

- B. Source Limitations: Obtain hollow-metal work from single source from single manufacturer.

## 2.2 REGULATORY REQUIREMENTS

- A. Fire-Rated Assemblies: Complying with NFPA 80 and listed and labeled by a qualified testing agency acceptable to authorities having jurisdiction for fire-protection ratings indicated, based on testing at positive pressure according to NFPA 252 or UL 10C.

- B. Fire-Rated, Borrowed-Light Assemblies: Complying with NFPA 80 and listed and labeled by a testing and inspecting agency acceptable to authorities having jurisdiction for fire-protection ratings indicated, based on testing according to NFPA 257 or UL 9.

## 2.3 INTERIOR DOORS AND FRAMES

- A. Construct interior doors and frames to comply with the standards indicated for materials, fabrication, hardware locations, hardware reinforcement, tolerances, and clearances, and as specified.
- B. Extra-Heavy-Duty Doors and Frames: SDI A250.8, Level 3.
  - 1. Physical Performance: Level A according to SDI A250.4.
  - 2. Doors:
    - a. Type: As indicated in the Door and Frame Schedule.
    - b. Thickness: 1-3/4 inches.
    - c. Face: Uncoated, cold-rolled steel sheet, minimum thickness of 0.053 inch.
    - d. Edge Construction: Model 2, Seamless.
    - e. Core: Manufacturer's standard kraft-paper honeycomb, polystyrene, polyurethane, polyisocyanurate, mineral-board, or vertical steel-stiffener core at manufacturer's discretion.
  - 3. Frames:
    - a. Materials: Uncoated, steel sheet, minimum thickness of 0.053 inch.
    - b. Construction: Full profile welded.
  - 4. Exposed Finish: Prime.
  - 5. Field paint with high performance coating.

## 2.4 EXTERIOR HOLLOW-METAL DOORS AND FRAMES

- A. Construct exterior doors and frames to comply with the standards indicated for materials, fabrication, hardware locations, hardware reinforcement, tolerances, and clearances, and as specified.
- B. Extra-Heavy-Duty Doors and Frames: SDI A250.8, Level 3.
  - 1. Physical Performance: Level A according to SDI A250.4.
  - 2. Doors:
    - a. Type: As indicated in the Door and Frame Schedule.
    - b. Thickness: 1-3/4 inches.
    - c. Face: Metallic-coated steel sheet, minimum thickness of 0.053 inch, with minimum A40 (ZF120) coating.
    - d. Edge Construction: Model 2, Seamless.

- e. Core: Manufacturer's standard kraft-paper honeycomb, polystyrene, polyurethane, polyisocyanurate, mineral-board, or vertical steel-stiffener core at manufacturer's discretion.
  - 1. Thermal-Rated Doors: Provide doors fabricated with thermal-resistance value (R-value) of not less than 2.1 deg F x h x sq. ft./Btu when tested according to ASTM C 1363.
- 3. Frames:
  - a. Materials: Metallic-coated steel sheet, minimum thickness of 0.053 inch, with minimum A40 (ZF120) coating.
  - b. Construction: Full profile welded.
- 4. Exposed Finish: Prime.
- 5. Field paint with high performance coating.

## 2.5 HOLLOW-METAL PANELS

- A. Provide hollow-metal panels of same materials, construction, and finish as adjacent door assemblies.

## 2.6 FRAME ANCHORS

- A. Jamb Anchors:
  - 1. Masonry Type: Adjustable strap-and-stirrup or T-shaped anchors to suit frame size, not less than 0.042 inch thick, with corrugated or perforated straps not less than 2 inches wide by 10 inches long; or wire anchors not less than 0.177 inch thick.
  - 2. Postinstalled Expansion Type for In-Place Concrete or Masonry: Minimum 3/8-inch-diameter bolts with expansion shields or inserts. Provide pipe spacer from frame to wall, with throat reinforcement plate, welded to frame at each anchor location.
- B. Floor Anchors: Formed from same material as frames, minimum thickness of 0.042 inch, and as follows:
  - 1. Monolithic Concrete Slabs: Clip-type anchors, with two holes to receive fasteners.

## 2.7 MATERIALS

- A. Cold-Rolled Steel Sheet: ASTM A 1008, Commercial Steel (CS), Type B; suitable for exposed applications.
- B. Hot-Rolled Steel Sheet: ASTM A 1011, Commercial Steel (CS), Type B; free of scale, pitting, or surface defects; pickled and oiled.
- C. Metallic-Coated Steel Sheet: ASTM A 653, Commercial Steel (CS), Type B.

- D. Frame Anchors: ASTM A 879, Commercial Steel (CS), 04Z (12G) coating designation; mill phosphatized.
  - 1. For anchors built into exterior walls, steel sheet complying with ASTM A 1008 or ASTM A 1011, hot-dip galvanized according to ASTM A 153, Class B.
- E. Inserts, Bolts, and Fasteners: Hot-dip galvanized according to ASTM A 153.
- F. Power-Actuated Fasteners in Concrete: Fastener system of type suitable for application indicated, fabricated from corrosion-resistant materials, with clips or other accessory devices for attaching hollow-metal frames of type indicated.
- G. Grout: ASTM C 476, except with a maximum slump of 4 inches, as measured according to ASTM C 143.
- H. Mineral-Fiber Insulation: ASTM C 665, Type I (blankets without membrane facing); consisting of fibers manufactured from slag or rock wool; with maximum flame-spread and smoke-developed indexes of 25 and 50, respectively; passing ASTM E 136 for combustion characteristics.
- I. Glazing: Comply with requirements in Section 24 "Glazing."
- J. Bituminous Coating: Cold-applied asphalt mastic, compounded for 15-mil dry film thickness per coat. Provide inert-type noncorrosive compound free of asbestos fibers, sulfur components, and other deleterious impurities.

## 2.8 FABRICATION

- A. Fabricate hollow-metal work to be rigid and free of defects, warp, or buckle. Accurately form metal to required sizes and profiles, with minimum radius for metal thickness. Where practical, fit and assemble units in manufacturer's plant. To ensure proper assembly at Project site, clearly identify work that cannot be permanently factory assembled before shipment.
- B. Hollow-Metal Doors:
  - 1. Steel-Stiffened Door Cores: Provide minimum thickness 0.026 inch, steel vertical stiffeners of same material as face sheets extending full-door height, with vertical webs spaced not more than 6 inches apart. Spot weld to face sheets no more than 5 inches o.c. Fill spaces between stiffeners with glass- or mineral-fiber insulation.
  - 2. Fire Door Cores: As required to provide fire-protection ratings indicated.
  - 3. Vertical Edges for Single-Acting Doors: Bevel edges 1/8 inch in 2 inches.
  - 4. Top Edge Closures: Close top edges of doors with flush closures of same material as face sheets.
  - 5. Bottom Edge Closures: Close bottom edges of doors with end closures or channels of same material as face sheets.
  - 6. Exterior Doors: Provide weep-hole openings in bottoms of exterior doors to permit moisture to escape. Seal joints in top edges of doors against water penetration.

- C. Hollow-Metal Frames: Where frames are fabricated in sections due to shipping or handling limitations, provide alignment plates or angles at each joint, fabricated of same thickness metal as frames.
1. Sidelight and Transom Bar Frames: Provide closed tubular members with no visible face seams or joints, fabricated from same material as door frame. Fasten members at crossings and to jambs by butt welding.
  2. Provide countersunk, flat- or oval-head exposed screws and bolts for exposed fasteners unless otherwise indicated.
  3. Grout Guards: Weld guards to frame at back of hardware mortises in frames to be grouted.
  4. Floor Anchors: Weld anchors to bottoms of jambs with at least four spot welds per anchor; however, for slip-on drywall frames, provide anchor clips or countersunk holes at bottoms of jambs.
  5. Jamb Anchors: Provide number and spacing of anchors as follows:
    - a. Masonry Type: Locate anchors not more than 16 inches from top and bottom of frame. Space anchors not more than 32 inches o.c., to match coursing, and as follows:
      - 1) Two anchors per jamb up to 60 inches high.
      - 2) Three anchors per jamb from 60 to 90 inches high.
      - 3) Four anchors per jamb from 90 to 120 inches high.
      - 4) Four anchors per jamb plus one additional anchor per jamb for each 24 inches or fraction thereof above 120 inches high.
    - b. Postinstalled Expansion Type: Locate anchors not more than 6 inches from top and bottom of frame. Space anchors not more than 26 inches o.c.
  6. Head Anchors: Two anchors per head for frames more than 42 inches wide and mounted in metal-stud partitions.
  7. Door Silencers: Except on weather-stripped frames, drill stops to receive door silencers as follows. Keep holes clear during construction.
    - a. Single-Door Frames: Drill stop in strike jamb to receive three door silencers.
    - b. Double-Door Frames: Drill stop in head jamb to receive two door silencers.
  8. Terminated Stops: Terminate stops 6 inches above finish floor with a 45-degree angle cut, and close open end of stop with steel sheet closure. Cover opening in extension of frame with welded-steel filler plate, with welds ground smooth and flush with frame.
- D. Fabricate concealed stiffeners and edge channels from either cold- or hot-rolled steel sheet.
- E. Hardware Preparation: Factory prepare hollow-metal work to receive templated mortised hardware; include cutouts, reinforcement, mortising, drilling, and tapping according to SDI A250.6, the Door Hardware Schedule, and templates.
1. Reinforce doors and frames to receive nontemplated, mortised, and surface-mounted door hardware.
  2. Comply with applicable requirements in SDI A250.6 and BHMA A156.115 for preparation of hollow-metal work for hardware.



- F. Stops and Moldings: Provide stops and moldings around glazed lites and louvers where indicated. Form corners of stops and moldings with mitered hairline joints.
  - 1. Single Glazed Lites: Provide fixed stops and moldings welded on secure side of hollow-metal work.
  - 2. Multiple Glazed Lites: Provide fixed and removable stops and moldings so that each glazed lite is capable of being removed independently.
  - 3. Provide fixed frame moldings on outside of exterior and on secure side of interior doors and frames.
  - 4. Provide loose stops and moldings on inside of hollow-metal work.
  - 5. Coordinate rabbet width between fixed and removable stops with glazing and installation types indicated.

## 2.9 STEEL FINISHES

- A. Prime Finish: Clean, pretreat, and apply manufacturer's standard primer.
  - 1. Shop Primer: Manufacturer's standard, fast-curing, lead- and chromate-free primer complying with SDI A250.10; recommended by primer manufacturer for substrate; compatible with substrate and field-applied coatings despite prolonged exposure.
- B. Field paint with high performance coating. Color to be **selected by Owner**.

## 2.10 ACCESSORIES

- A. Mullions and Transom Bars: Join to adjacent members by welding or rigid mechanical anchors.
- B. Grout Guards: Formed from same material as frames, not less than 0.016 inch thick.

## PART 3 - EXECUTION

### 3.1 EXAMINATION

- A. Examine substrates, areas, and conditions, with Installer present, for compliance with requirements for installation tolerances and other conditions affecting performance of the Work.
- B. Examine roughing-in for embedded and built-in anchors to verify actual locations before frame installation.
- C. Prepare written report, endorsed by Installer, listing conditions detrimental to performance of the Work.
- D. Proceed with installation only after unsatisfactory conditions have been corrected.

### 3.2 PREPARATION

- A. Remove welded-in shipping spreaders installed at factory. Restore exposed finish by grinding, filling, and dressing, as required to make repaired area smooth, flush, and invisible on exposed faces.
- B. Drill and tap doors and frames to receive nontemplated, mortised, and surface-mounted door hardware.

### 3.3 INSTALLATION

- A. General: Install hollow-metal work plumb, rigid, properly aligned, and securely fastened in place. Comply with Drawings and manufacturer's written instructions.
- B. Hollow-Metal Frames: Install hollow-metal frames of size and profile indicated. Comply with SDI A250.11 or NAAMM-HMMA 840 as required by standards specified.
  - 1. Set frames accurately in position; plumbed, aligned, and braced securely until permanent anchors are set. After wall construction is complete, remove temporary braces, leaving surfaces smooth and undamaged.
    - a. At fire-rated openings, install frames according to NFPA 80.
    - b. Where frames are fabricated in sections because of shipping or handling limitations, field splice at approved locations by welding face joint continuously; grind, fill, dress, and make splice smooth, flush, and invisible on exposed faces.
    - c. Install frames with removable stops located on secure side of opening.
    - d. Install door silencers in frames before grouting.
    - e. Remove temporary braces necessary for installation only after frames have been properly set and secured.
    - f. Check plumb, square, and twist of frames as walls are constructed. Shim as necessary to comply with installation tolerances.
    - g. Field apply bituminous coating to backs of frames that will be filled with grout containing antifreezing agents.
  - 2. Floor Anchors: Provide floor anchors for each jamb and mullion that extends to floor, and secure with postinstalled expansion anchors.
    - a. Floor anchors may be set with power-actuated fasteners instead of postinstalled expansion anchors if so indicated and approved on Shop Drawings.
  - 3. Masonry Walls: Coordinate installation of frames to allow for solidly filling space between frames and masonry with grout.
  - 4. Concrete Walls: Solidly fill space between frames and concrete with mineral-fiber insulation.
  - 5. In-Place Concrete or Masonry Construction: Secure frames in place with postinstalled expansion anchors. Countersink anchors, and fill and make smooth, flush, and invisible on exposed faces.
  - 6. Installation Tolerances: Adjust hollow-metal door frames for squareness, alignment, twist, and plumb to the following tolerances:

- a. Squareness: Plus or minus 1/16 inch, measured at door rabbet on a line 90 degrees from jamb perpendicular to frame head.
  - b. Alignment: Plus or minus 1/16 inch, measured at jambs on a horizontal line parallel to plane of wall.
  - c. Twist: Plus or minus 1/16 inch, measured at opposite face corners of jambs on parallel lines, and perpendicular to plane of wall.
  - d. Plumbness: Plus or minus 1/16 inch, measured at jambs at floor.
- C. Hollow-Metal Doors: Fit hollow-metal doors accurately in frames, within clearances specified below. Shim as necessary.
- 1. Non-Fire-Rated Steel Doors:
    - a. Between Door and Frame Jambs and Head: 1/8 inch plus or minus 1/32 inch.
    - b. Between Edges of Pairs of Doors: 1/8 inch to 1/4 inch plus or minus 1/32 inch.
    - c. At Bottom of Door: 5/8 inch plus or minus 1/32 inch.
    - d. Between Door Face and Stop: 1/16 inch to 1/8 inch plus or minus 1/32 inch.
  - 2. Fire-Rated Doors: Install doors with clearances according to NFPA 80.
- D. Glazing: Comply with installation requirements in Section 088000 "Glazing" and with hollow-metal manufacturer's written instructions.
- 1. Secure stops with countersunk flat- or oval-head machine screws spaced uniformly not more than 9 inches o.c. and not more than 2 inches o.c. from each corner.

### 3.4 ADJUSTING AND CLEANING

- A. Final Adjustments: Check and readjust operating hardware items immediately before final inspection. Leave work in complete and proper operating condition. Remove and replace defective work, including hollow-metal work that is warped, bowed, or otherwise unacceptable.
- B. Remove grout and other bonding material from hollow-metal work immediately after installation.
- C. Prime-Coat Touchup: Immediately after erection, sand smooth rusted or damaged areas of prime coat and apply touchup of compatible air-drying, rust-inhibitive primer.
- D. Metallic-Coated Surface Touchup: Clean abraded areas and repair with galvanizing repair paint according to manufacturer's written instructions.
- E. Factory-Finish Touchup: Clean abraded areas and repair with same material used for factory finish according to manufacturer's written instructions.
- F. Touchup Painting: Cleaning and touchup painting of abraded areas of paint are specified in painting Sections.

\*\* END OF SECTION \*\*



SERIES	CF/O
16 Ga. Steel	

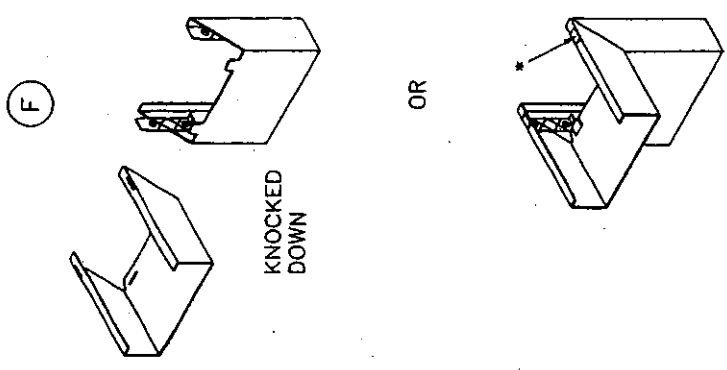
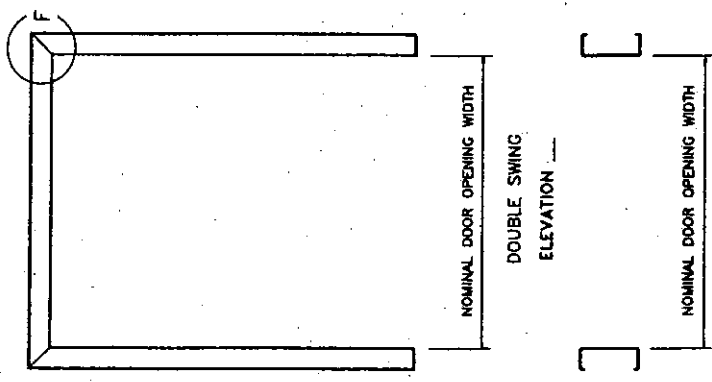
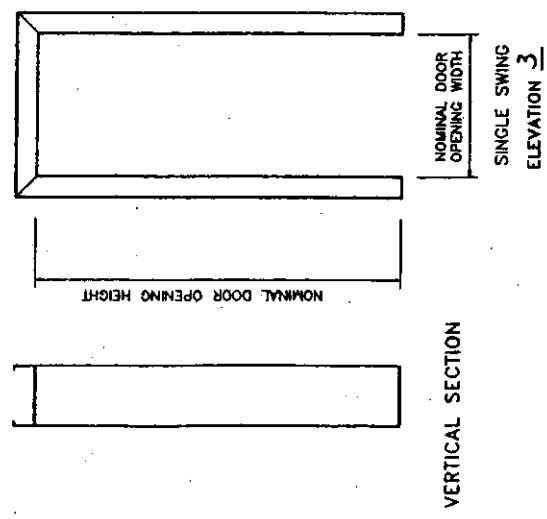

Series CF/O DEPTHS	
DIM B	3" THRU 9-3/4"

C.R. steel is standard.  
ASTM A525 galvanized steel is optional.

	FOR HAND & SWING SEE DOOR SCHEDULE
	FOR ANCHORAGE SEE DOOR SCHEDULE & ANCHOR SHEET (DO NOT USE WS, MS, OR PFA TYPE)

# SERIES/PROFILE CF/O CASED OPENING FRAMES

		Caco Door Products A United Division Company	
DRAWN BY	DATE	ISSUE DATE	BY
CHK'D BY	DATE	REVISIONS	
SHT 10 OF 27	CONTRACT NO.		

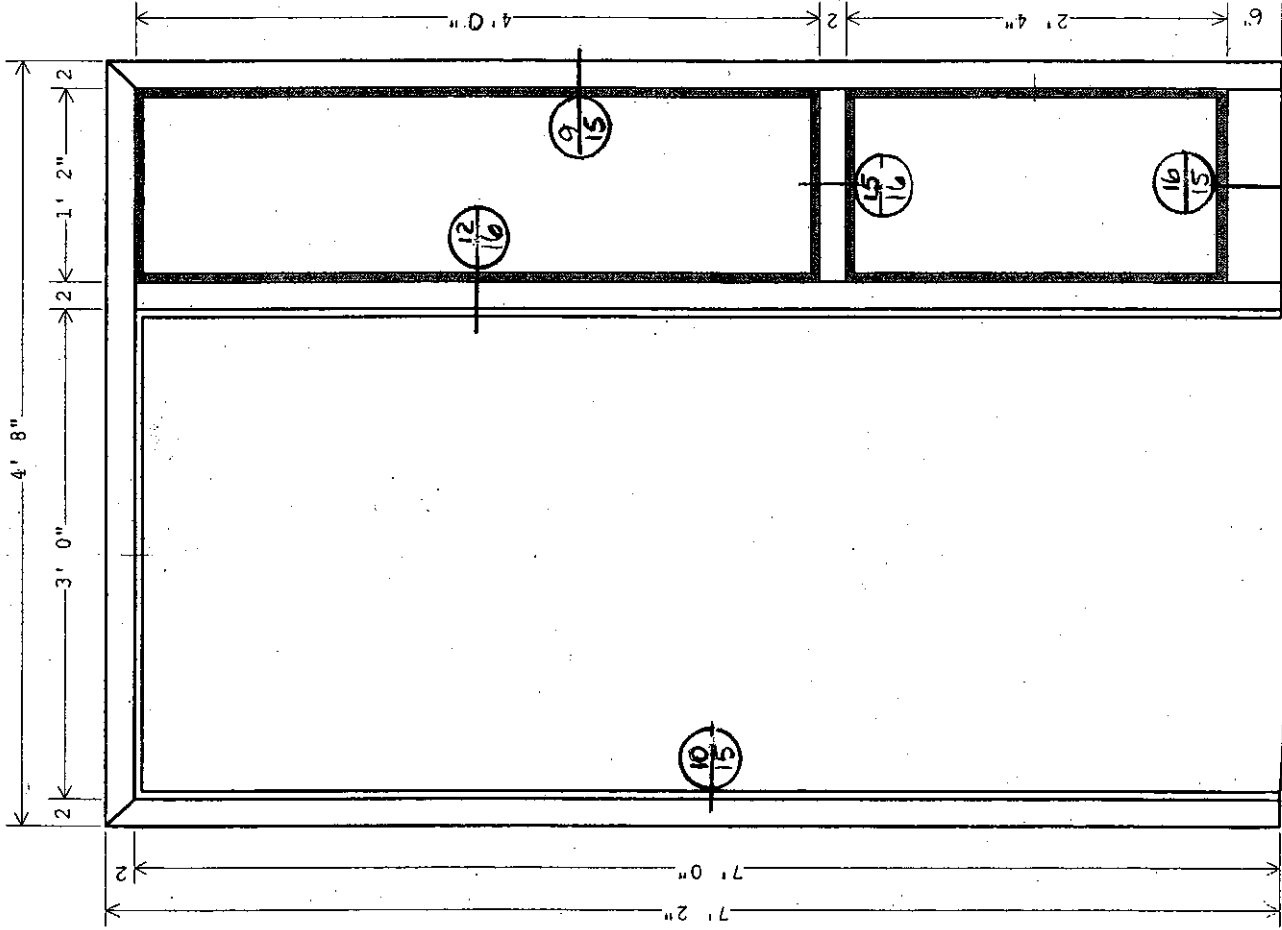

ELEV 4  
19/1 (LHR)

**1" Glass by Others**  
 CAPITOL DOOR AND HARDWARE COMPANY  
 774 CORPORATE CIRCLE  
 NEW CUMBERLAND, PA 17070

Project: \_\_\_\_\_ Code: LIBRARY  
 Elevation: SINGLE SIDELITE & HORIZONTAL MULLION RIGHT Code: HSL4-R  
 Drawn by: cmh Date: 12/28/00 11:13 Scale: 1' 2" = 1" Page: 1

11/27

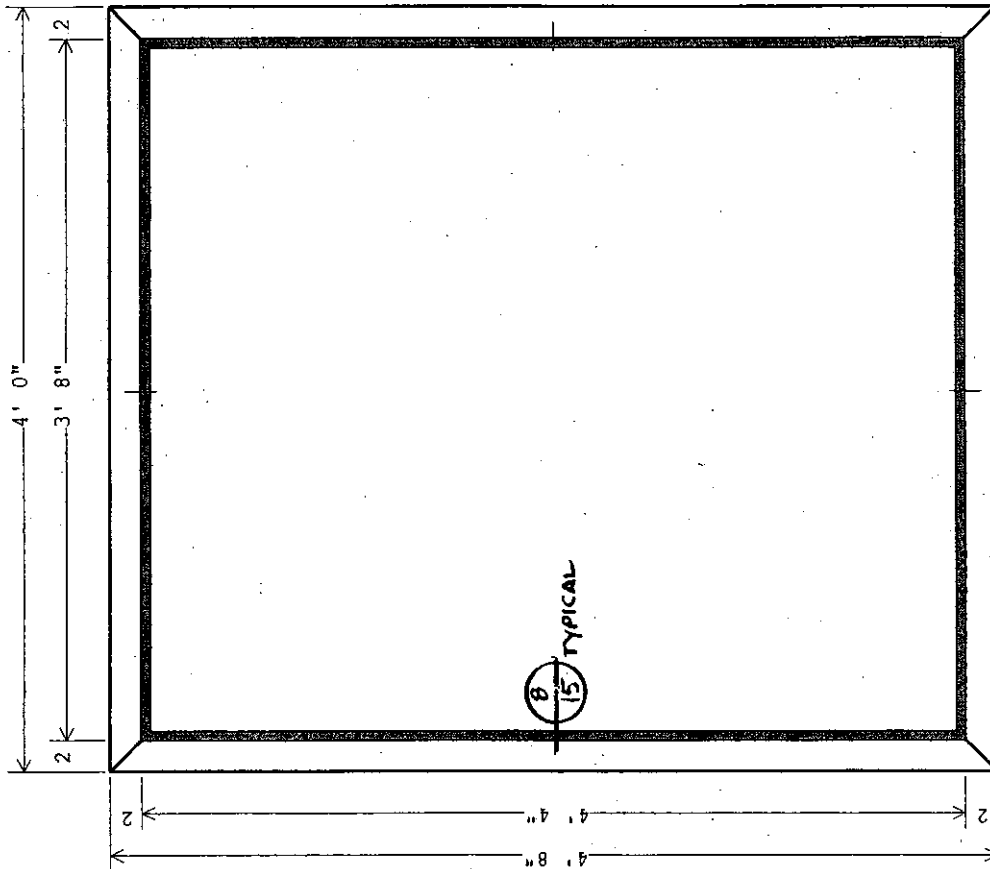

ELEV 5  
HM-1, HM-2

**1/4" GLASS SUPPLIED AND INSTALLED BY OTHERS**

CAPITOL DOOR AND HARDWARE COMPANY  
774 CORPORATE CIRCLE  
NEW CUMBERLAND, PA 17070

Project: The library  
Elevation: 1BL 30 x 40  
Drawn by: cmh

Code: LIBRARY  
Code: 1BL

Date: 12/28/00 10:45

Scale: 1' 0" = 1"

Page: 1

12/27

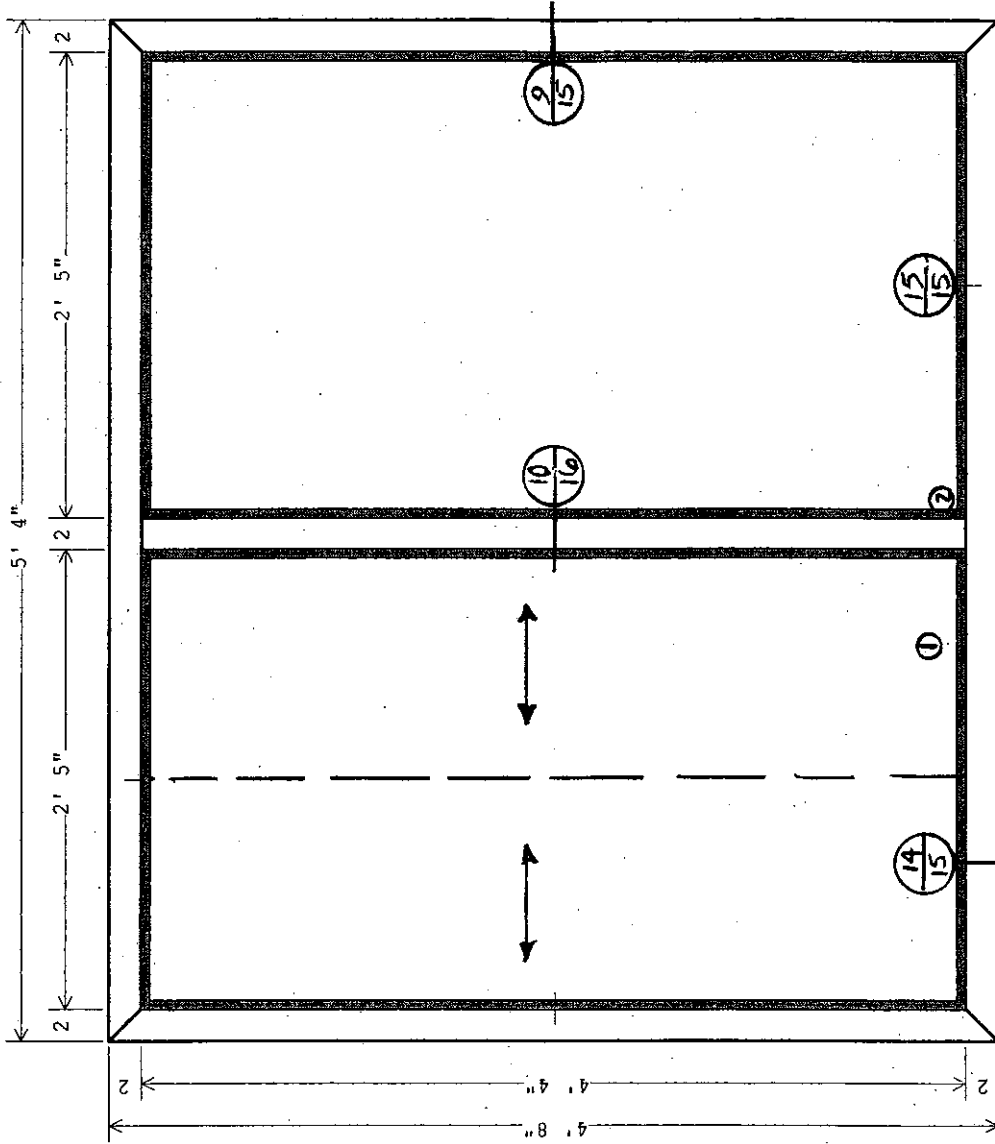

ELEV 6  
HM-3

① SLIDING GLASS AND TRACK BY OTHERS (NO GLAZING BEAD)  
 ② 1/4" GLASS SUPPLIED AND INSTALLED BY OTHERS

CAPITOL DOOR AND HARDWARE COMPANY  
 774 CORPORATE CIRCLE  
 NEW CUMBERLAND, PA 17070

Project: The library  
 Elevation: 2BL 80 x 40  
 Drawn by: cmh

Code: LIBRARY  
 Code: 2BL

Page: 1

Scale: 1" 0" = 1"

Date: 12/28/00 10:48

13/27



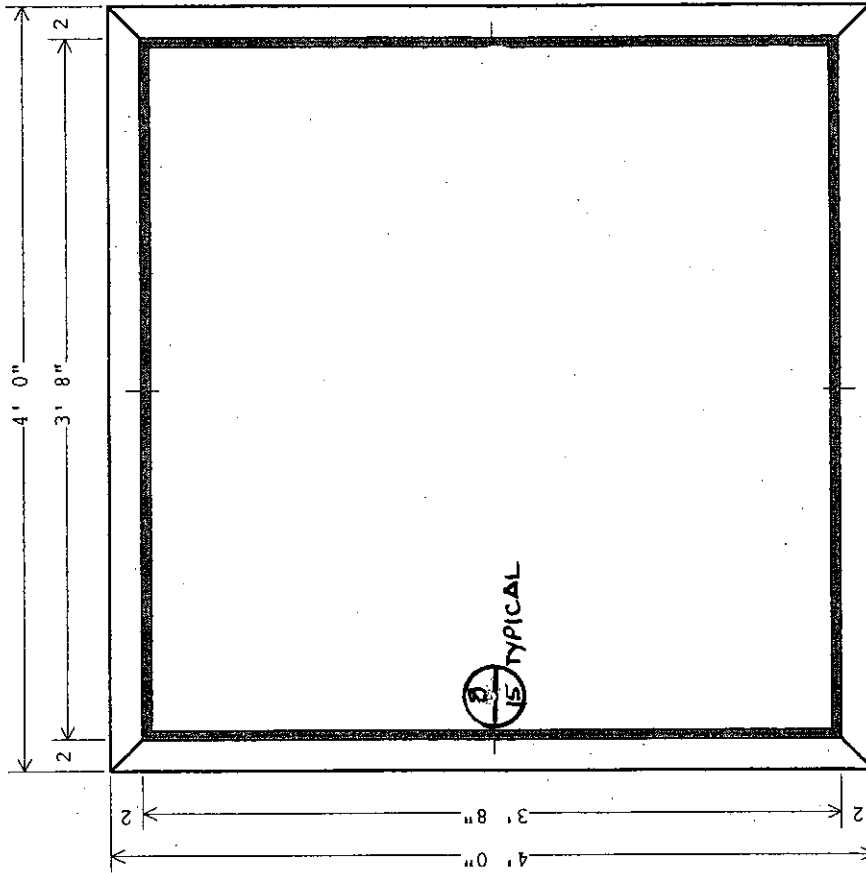

ELEV 7  
HM-4

**1/4" GLASS SUPPLIED & INSTALLED BY OTHERS**

CAPITOL DOOR AND HARDWARE COMPANY  
774 CORPORATE CIRCLE  
NEW CUMBERLAND, PA 17070

Project: The library  
Elevation: 1BL 30 x 40  
Drawn by: cmh

Code: LIBRARY  
Code: 1BL  
Date: 12/28/00 10:49  
Scale: 1' 0" = 1"

Page: 1

14/27

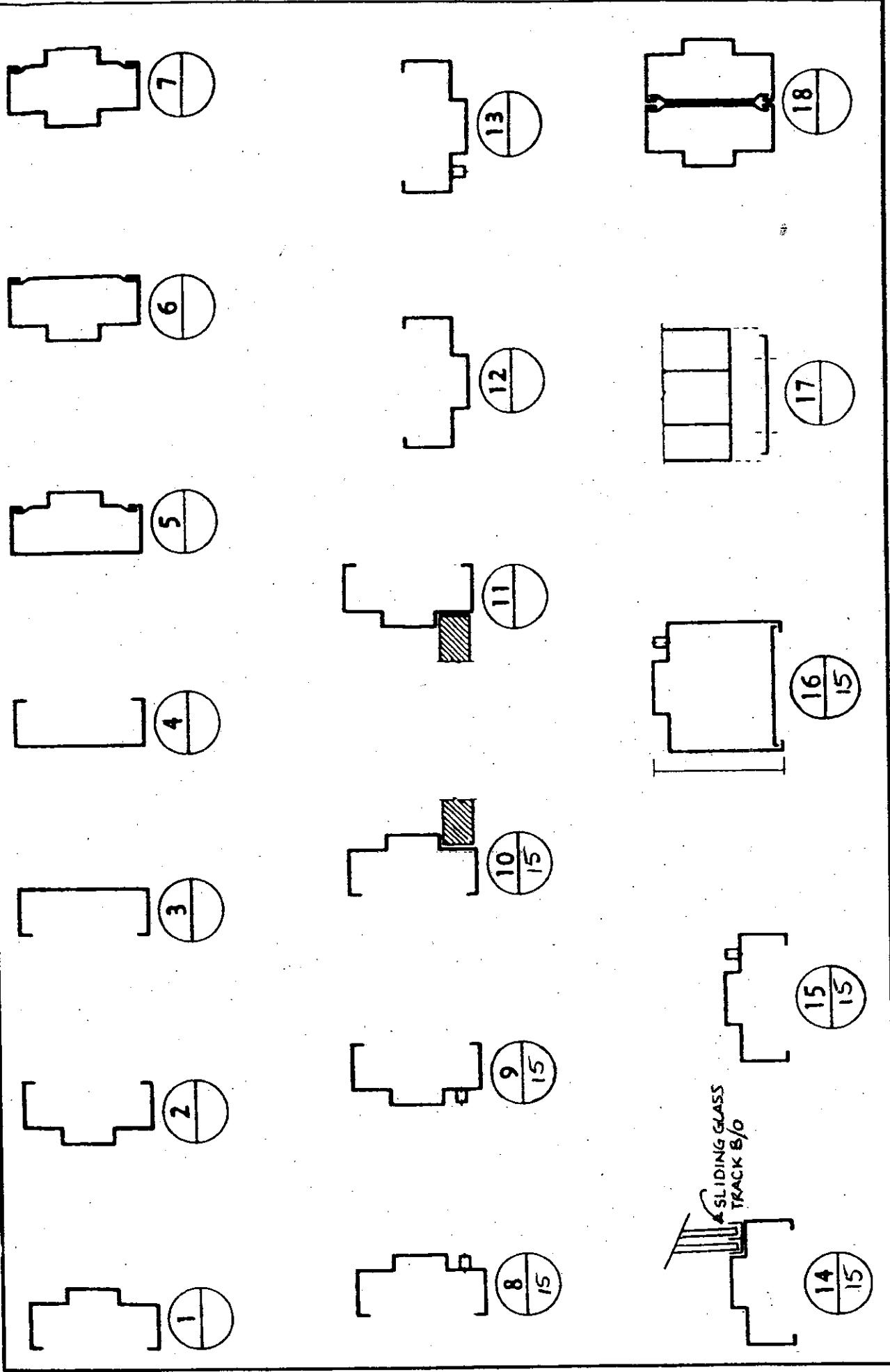

PROJECT	DATE		DRAWN BY
	REVISION		SHEET 15 OF 27

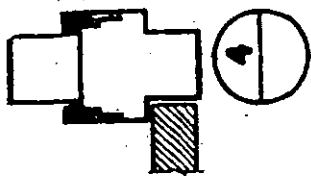

4

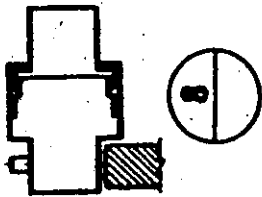

8

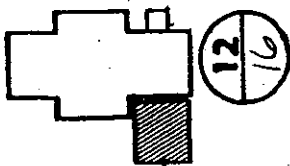

12/16

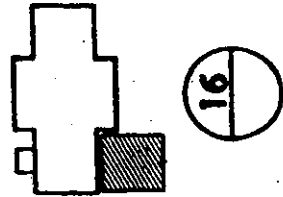

16

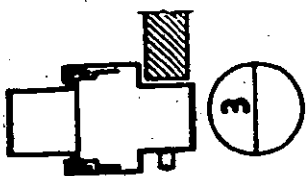

3

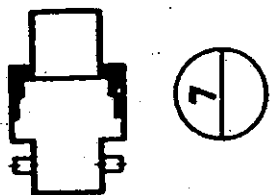

7

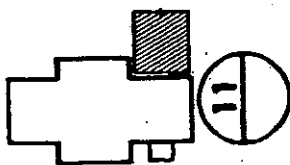

11

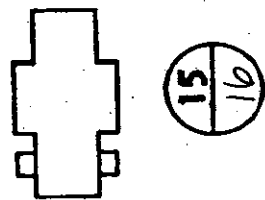

15/16

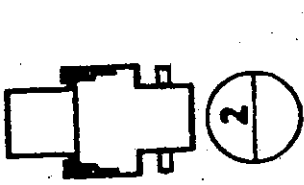

2

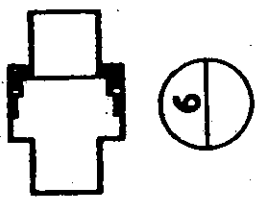

6

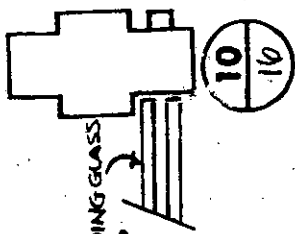

10/16

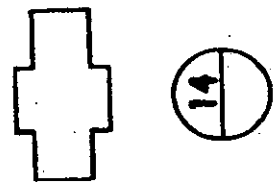

14

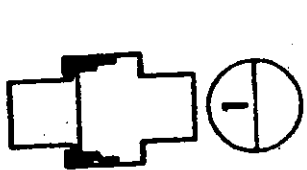

1

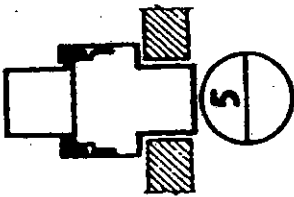

5





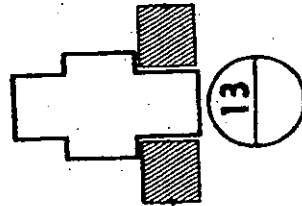

9

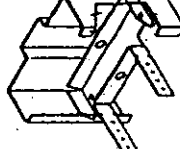
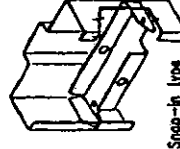
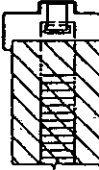
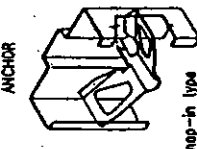
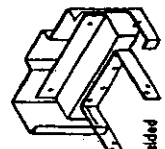
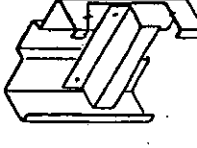
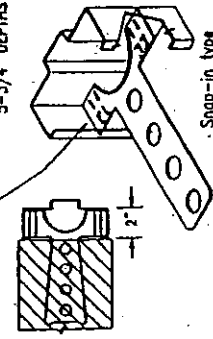
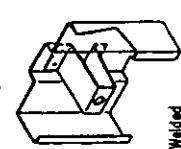
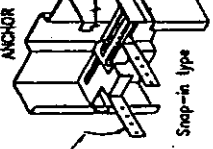

13

PROJECT	DATE	DRAWN BY
	REVISION	SHEET 16 OF 27

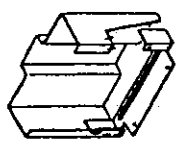
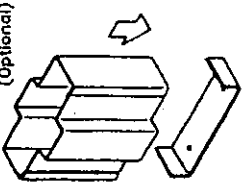
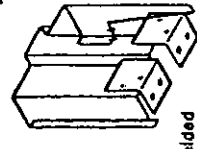
JAMB ANCHORS		FLOOR ANCHORS	
<p><b>WMA</b> SERIES SF AND CF STANDARD ANCHOR</p>  <p>Snap-in type</p> <p><b>WIRE MASONRY ANCHOR</b> (for 2" thru 8-3/4" depths)</p>	<p><b>MT</b> FOR SPECIAL DEPTHS AND OVERSIZE FRAMES</p>  <p>2"</p> <p>Available on special order only</p> <p>Snap-in type</p> <p>(For 6-3/4", 7-3/4", and 8-3/4" depths)</p>	<p><b>WS</b> SERIES SF STANDARD ANCHOR</p>  <p>Snap-in type</p> <p>Pocket provided for 1/2" or 5/8" thick wall board</p> <p>Flush with stud</p> <p>2"</p> <p><b>WOOD STUD ANCHOR</b> (Used also for METAL STUD Walls)</p>	<p><b>MS</b> SERIES SF DEPTH ONLY 4-3/4" and 5-3/4"</p>  <p>Snap-in type</p> <p>Pocket provided for 1/2" or 5/8" thick wall board</p> <p>Flush with stud</p> <p>2"</p> <p><b>METAL STUD ANCHOR</b></p>
<p><b>YS</b></p>  <p>Available on special order only</p> <p>Welded</p> <p><b>YOKE AND STRAP MASONRY ANCHOR</b></p>	<p><b>EO</b> SERIES SF AND CF STANDARD ANCHOR</p>  <p>Snap-in type</p> <p>2"</p> <p><b>EXISTING OPENING ANCHOR</b> EO/SF: 4-1/2" thru 6-3/4" depth EO/SF: 6-7/8" thru 8-3/4" depth</p>	<p><b>WSZS</b> (Optional)</p>  <p>Welded</p> <p>5/8"</p> <p>DESIGNATE WALL CONFIGURATION SO THAT PROPER POCKET CAN BE PROVIDED</p> <p><b>WOOD STUD "Z" STRAP ANCHOR</b></p>	<p><b>MSZ1</b> (Optional)</p>  <p>Welded</p> <p>5/8"</p> <p><b>METAL STUD "Z" ANCHOR</b></p>
<p><b>MT</b> 4-3/4" and 5-3/4" DEPTHS</p>  <p>2"</p> <p>Snap-in type</p> <p><b>MASONRY "T" ANCHOR (ADJUSTABLE)</b></p>	<p><b>EO/N</b> (Optional)</p>  <p>Welded</p> <p>Used where standard anchor is not applicable</p> <p><b>EXISTING OPENING ANCHOR</b></p>	<p><b>ADJ/STUD</b> SPECIAL DEPTH STANDARD ANCHOR</p>  <p>Snap-in type</p> <p>3/4"</p> <p>2"</p> <p>Setup anchor and bend tailpieces to grip stud</p> <p><b>ADJUSTABLE ANCHOR FOR STUD WALLS</b> 3-3/4" thru 8-3/4" depth</p>	<p><b>MSZ2</b> (Optional)</p>  <p>Welded</p> <p>Flush with stud</p> <p>DESIGNATE WALL CONFIGURATION SO THAT PROPER POCKET CAN BE PROVIDED</p> <p><b>METAL STUD "Z" ANCHOR</b></p>
<p><b>FFA</b> SERIES SF STANDARD ANCHOR</p>  <p>Anchor is attached to frame in the field by means of SMS</p> <p><b>FIXED FLOOR ANCHOR</b></p>	<p><b>SLFA</b> (Optional)</p>  <p>IN-FIELD: FASTEN ANCHOR TO FLOOR. SLIP-FIT FRAME OVER ANCHOR</p> <p><b>SIDELITE FLOOR ANCHOR</b></p>	<p><del>SFA</del> (Optional)</p>  <p>Welded</p> <p>ANCHOR MAY BE CONTINUOUS OR TWO PIECE AS SHOWN.</p> <p><b>SPECIAL SIZE FLOOR ANCHOR</b></p>	

**Series SF and CF FRAME ANCHORS**

<p>ANCHOR QUANTITIES</p>	<p>3 PER JAMB FOR HEIGHTS UP TO 7-2 AND ONE FLOOR ANCHOR 4 PER JAMB FOR HEIGHTS FROM 7-3 THRU 9-0 AND ONE FLOOR ANCHOR ONE ADDITIONAL JAMB ANCHOR FOR EACH ADDITIONAL TWO FEET IN HEIGHT OR FRACTION THEREOF ONE ADDITIONAL JAMB ANCHOR IN LIEU OF FLOOR ANCHOR FOR EO AND WS TYPE CONDITIONS</p>
<p>DRAWN BY _____ DATE _____</p> <p>CHK'D BY _____ DATE _____</p> <p>SHT <u>17</u> OF <u>22</u></p> <p>CONTRACT NO. _____</p>	<p>ISSUE DATE _____</p> <p>REVISIONS _____ BY _____</p>





## FRAME INSTALLATION MASONRY and STUD WALLS

**JOB SITE STORAGE:** Store frames off the ground on wood runners or skids. Do not store directly on the ground. Cover frames with tarpaulin or plastic but do insure that adequate ventilation is provided to eliminate moisture condensation. When frames are to be fully grouted and when plaster or mortar contain "anti-freeze" agents, the inside of the frames should be coated with a bituminous, water-resistant paint by the installation contractor.

### ASSEMBLY of FRAME

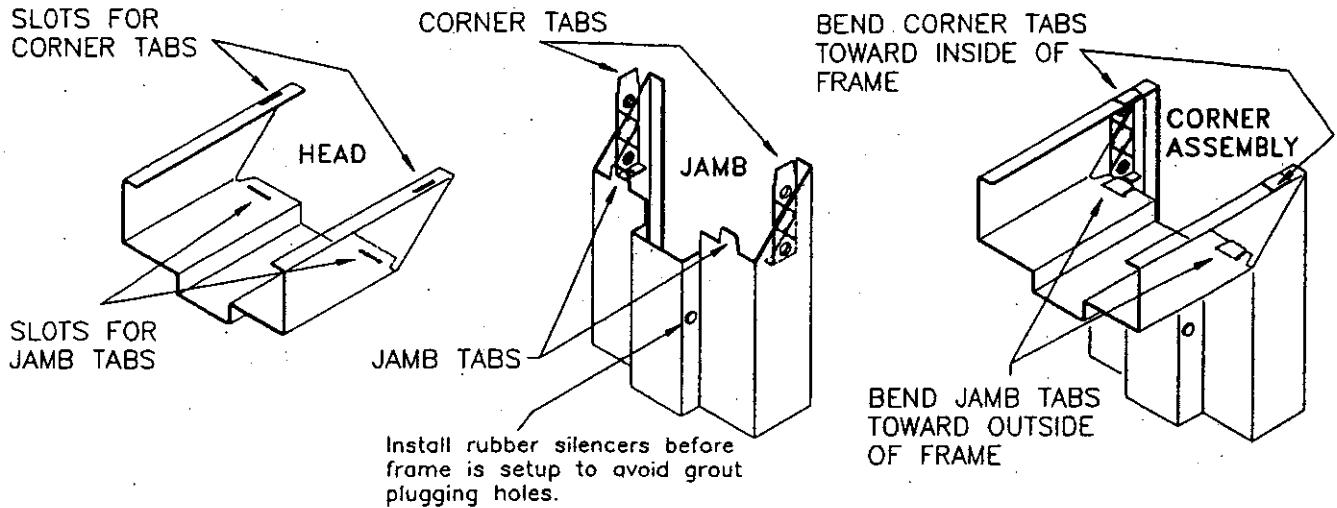

### PLUMBING FRAME

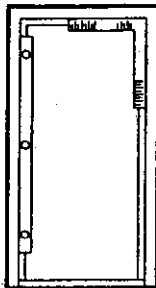

#### SQUARING THE FRAME

The installer should use wood spreaders (as described at right), a carpenters level (the longer the better), and a carpenters square (the bigger the better). Set the frame in the desired location. Level head and plumb jambs. Shim under jambs if necessary.

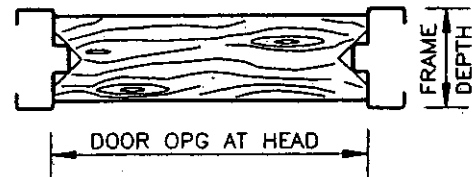

#### SPREADER

Typical wood spreader must be square and made from lumber at least 1" thick. Length of spreader equals door opening width at the head. Cut clearance notches for frame stops as shown. Spreader must be nearly as wide as frame depth for proper installation.

10/27

## MASONRY WALL CONSTRUCTION

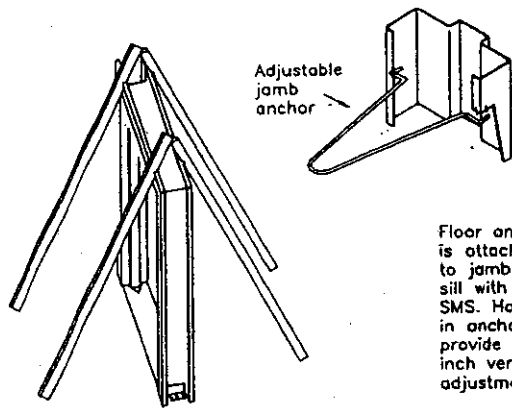

**BRACING THE FRAME**

*NOTE: If frame is received setup and welded, remove and discard the temporary metal supports that are tack welded to jambs at sill before starting installation.*

Brace the frame as shown or shore to ceiling. Do not brace in the direction of intended wall. Plumb and square jambs. Set spreader. Attach jambs to floor through floor anchor.

Floor anchor is attached to jamb at sill with (2) SMS. Holes in anchor provide one inch vertical adjustment.

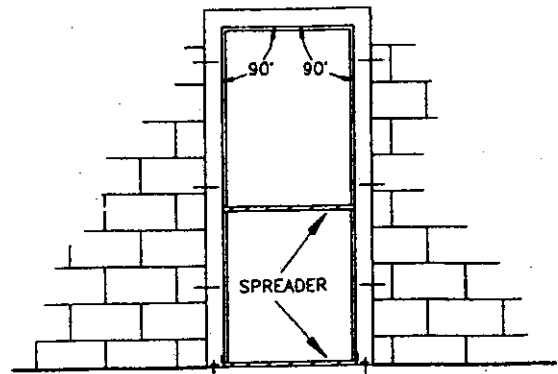
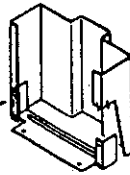

**INSTALLING THE FRAME**

Set and plumb frame. Install jamb anchors at hinge levels as wall is laid up. (3 anchors for heights to 7'-2" -- one more anchor per jamb for each additional 2 feet of height or fraction thereof.) Grout frame in the area of the anchors. A second spreader should be used at mid-point of opening to maintain the door opening dimension. Continually check plumb and square as wall progresses. **CHECK:** The difference between diagonals measured from opposite corners should not exceed 1/16".

## WOOD or METAL STUD WALL CONSTRUCTION

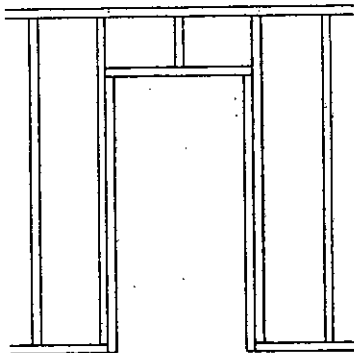

**ROUGH STUD OPENING**

ADD 3/8" TO OVERALL FRAME WIDTH.  
ADD 1/8" TO OVERALL FRAME HEIGHT

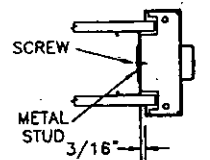

**DET. A**

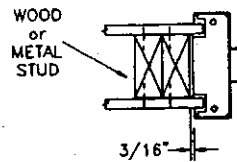

**DET. B**

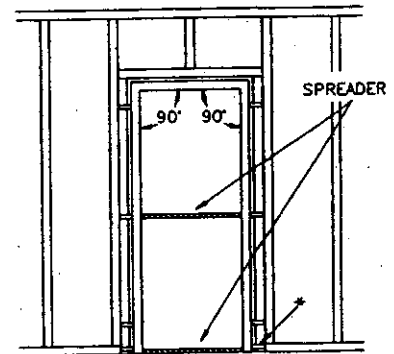

**INSTALLING THE FRAME**

1. Build the rough opening in wall allowing 3/16" clearance between upright stud and frame jamb and 1/8" clearance between header and top of door frame. \*

2. Insert jamb anchors in frame throat and top into place with a hammer. Place at hinge location and directly opposite on strike jamb. Position anchors also at sill.

3. Place frame in rough opening.

4. Set spreader and level frame. Shim jambs if necessary.

\*If you choose to erect door frame before wall framing: brace frame and anchor at sill per masonry procedure above, then butt studs to door frame.

5. Square and fasten top anchors to stud on ONE JAMB ONLY. Check plumb and square of door frame and continue to fasten balance of anchors to studs. Repeat on opposite jamb.

6A. If your anchor looks like Det. A, fasten anchor to metal stud thru web of channel using suitable fastener for sheet metal.

6B. If your anchor looks like Det. B, bend anchor tabs around stud and fasten tabs with suitable fastener.

7. Maintain necessary clearance between frame returns and stud for inserting wall board. Do not install wall board until you are sure that frame is plumb and square.

19/61



**Ceco Door Products**  
A United Dominion Company

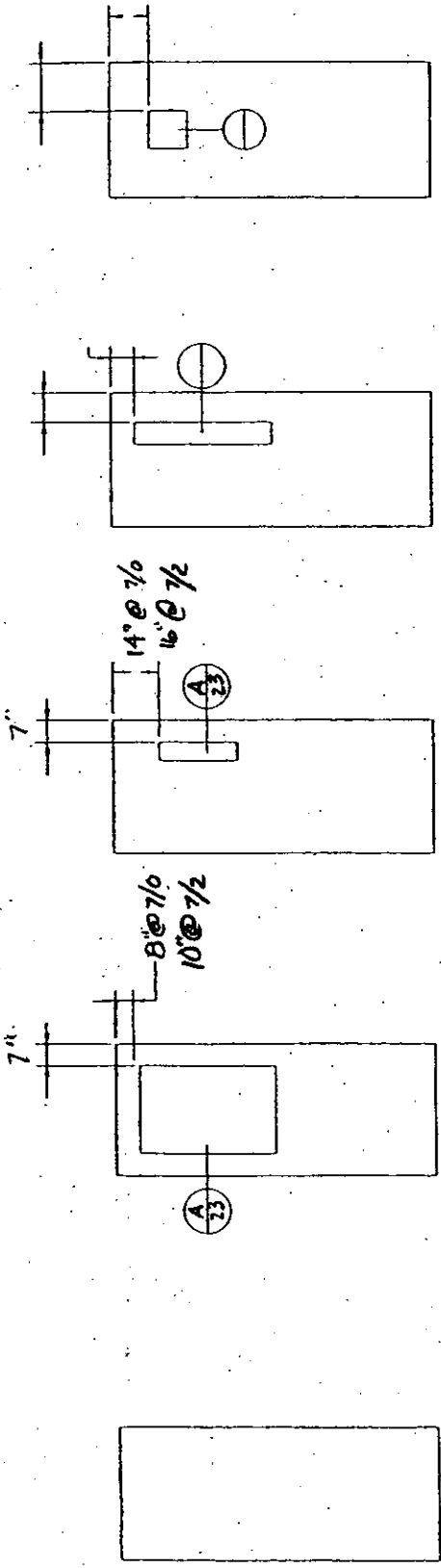

ELEV. 4 ELEV. 2 ELEV. 3 ELEV. 3

22' X 30' LITE  
5 X 20 LITE  
(1/4" GLASS BY OTHERS)

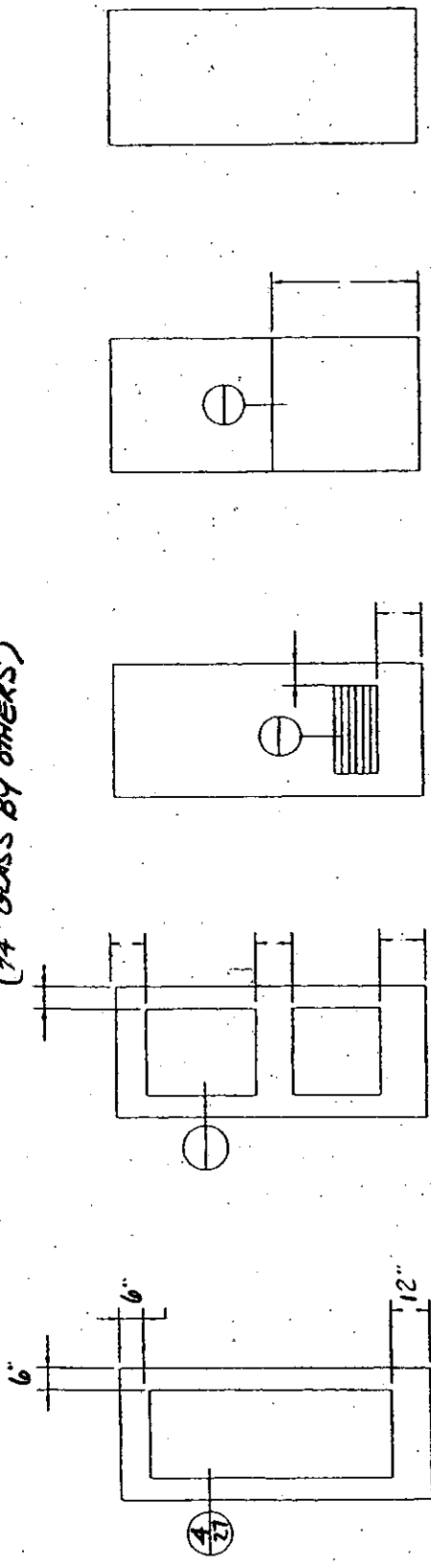

ELEV. 1 ELEV. 1 ELEV. 1 ELEV. 1

1" INSULATED GLASS BY OTHERS

JOB NAME:

DRAWN BY:

DATE:

JOB #

TITLE:

SHEET # 20 OF 27

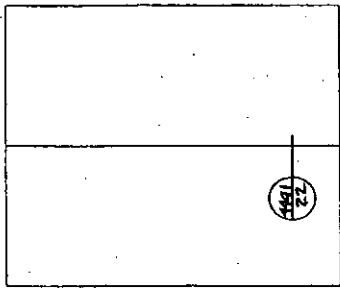

ELEV. 5

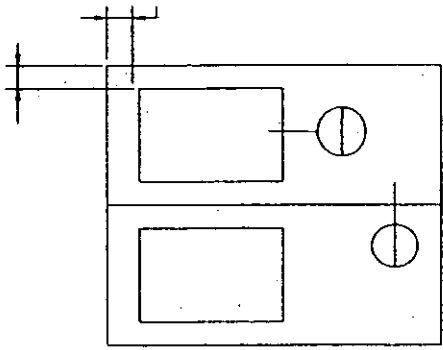

ELEV. \_\_\_\_\_

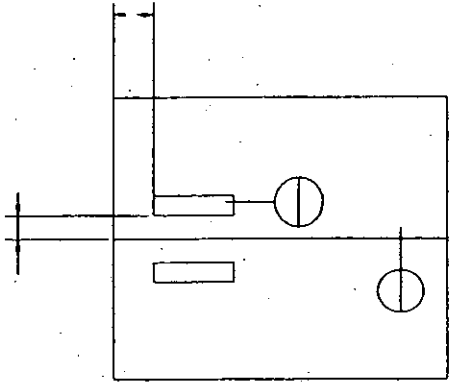

ELEV. \_\_\_\_\_

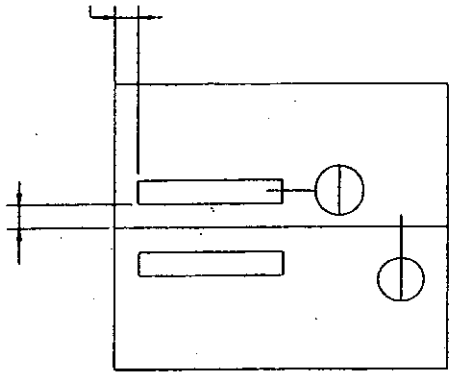

ELEV. \_\_\_\_\_

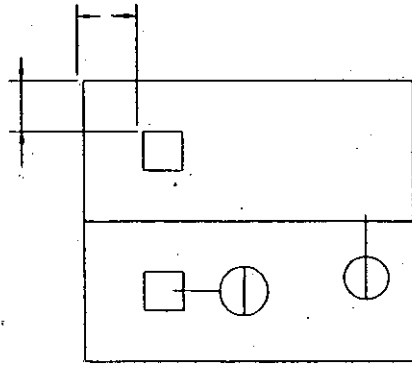

ELEV. \_\_\_\_\_

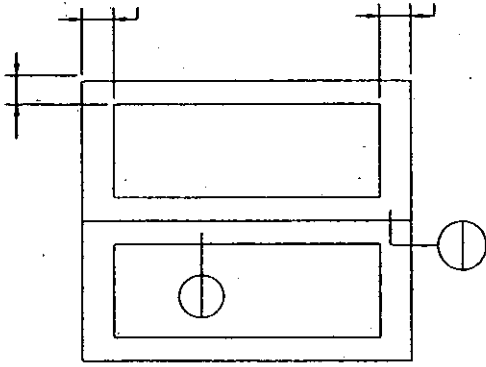

ELEV. \_\_\_\_\_

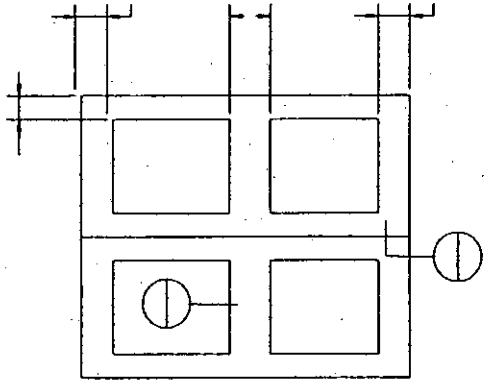

ELEV. \_\_\_\_\_

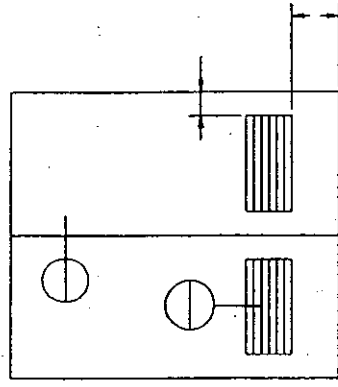

ELEV. \_\_\_\_\_

JOB NAME:

DRAWN BY:

DATE:

JOB #

TITLE:

SHEET # 21

OF 27



**ASTRAGALS**

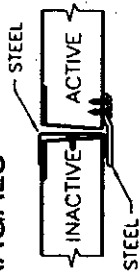

**4441**  
 OVERLAPPING ASTRAGAL  
 FOR 1-3/4" THICK DOORS

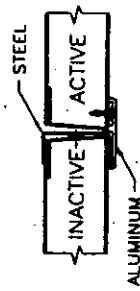

**4451**  
 OVERLAPPING ASTRAGAL  
 WITH OPTIONAL POLY-PILE INSERT



**4471**  
 OVERLAPPING ASTRAGAL



**FLAT PLATE ASTRAGAL**  
**4491 PLAIN STEEL** (welded on)  
 (Medallion & Thrulite Doors only)  
**4481 STAINLESS STEEL** (screwed on)  
 (Stainless steel doors only)

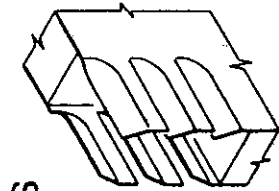

**"L" DESIGN (PIERCED)**  
 FOR HONEYCOMB CORE DOORS

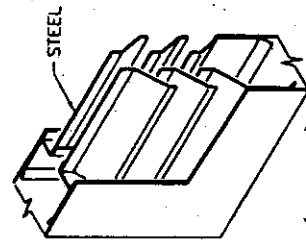

**4684 (FLUSH)**  
 FOR MEDALLION DOORS (ONLY)

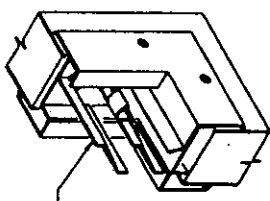

**4605/FLDL (ADJUSTABLE)**

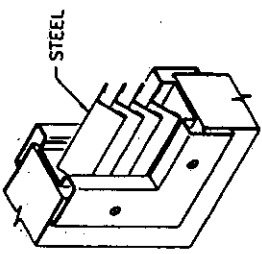

**4631 (INVERTED "V")**

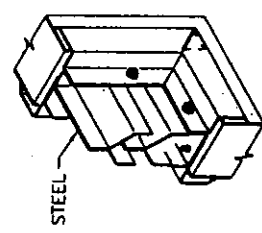

**4634 (FIXED SLAT)**

**LOUVERS**

**GLASS LITE TRIM KITS**  
 (G, V, and N)

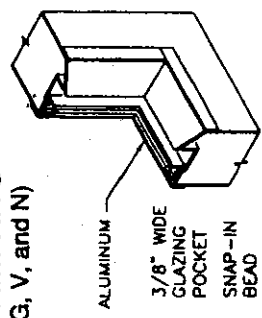

**4831 (APPLIED)**

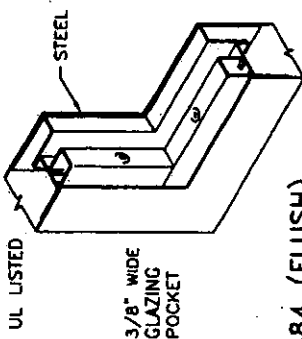

**4884 (FLUSH)**  
 FOR MEDALLION AND THRULITE DOORS

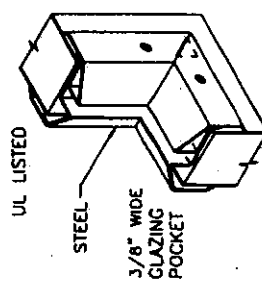

**4834 (APPLIED)**

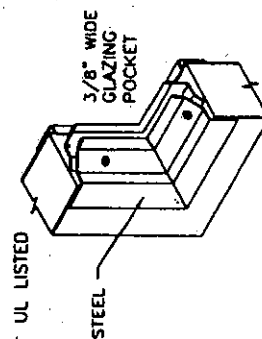

**4841 (APPLIED)**

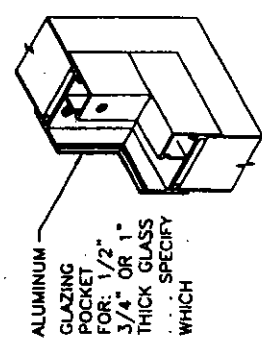

**4900 (APPLIED)**

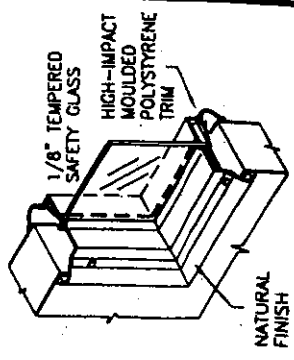

**4854 (Applied)**  
 FOR STAINLESS STEEL DOORS (ONLY)

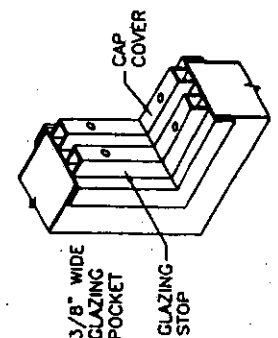

**4854 (Applied)**  
 FOR STAINLESS STEEL DOORS (ONLY)

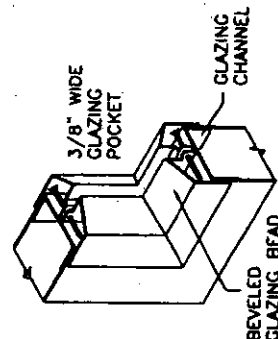

**LoPro (Applied)**

**DOOR ACCESSORIES**

(FOR 1-3/4" DOORS)

<b>Ceco Door Products</b> A United Dominion Company		DATE _____	DATE _____	ISSUE DATE _____	REVISIONS _____	BY _____
DRAWN BY _____	CHK'D BY _____	CONTRACT NO. _____		ISSUE DATE _____	REVISIONS _____	BY _____
SHT 22	OF 27					

# MODEL 115 FIRE DOOR LIGHT FRAMES

PATENT NO. 4,550,542

## ORDER INFORMATION:

ORDER SIZE = INSIDE DIMENSION OF FRAME, as illustrated (W x H)

CUTOUT SIZE = ORDER SIZE + 1-1/2", as illustrated

GLASS SIZE = ORDER SIZE + 3/4", as illustrated

### UL & WHI LISTED

Meets UL10B requirements for NEGATIVE PRESSURE and

UL10C & UBC 7-2 (1997) requirements for POSITIVE PRESSURE

For details refer to AMS Listing Specifications.

Fire Tested with NO glazing compound, tape, or intumescent.

STD SPECS: 18 GA. CRS with BEIGE PRIMER

### SPECIALS:

- 18 GA. GALVANIZED
- 18 GA. STAINLESS STEEL
- SPECIAL COLORS
- VENEER WRAPPED

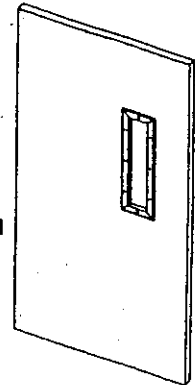

TYPICAL INSTALLATION

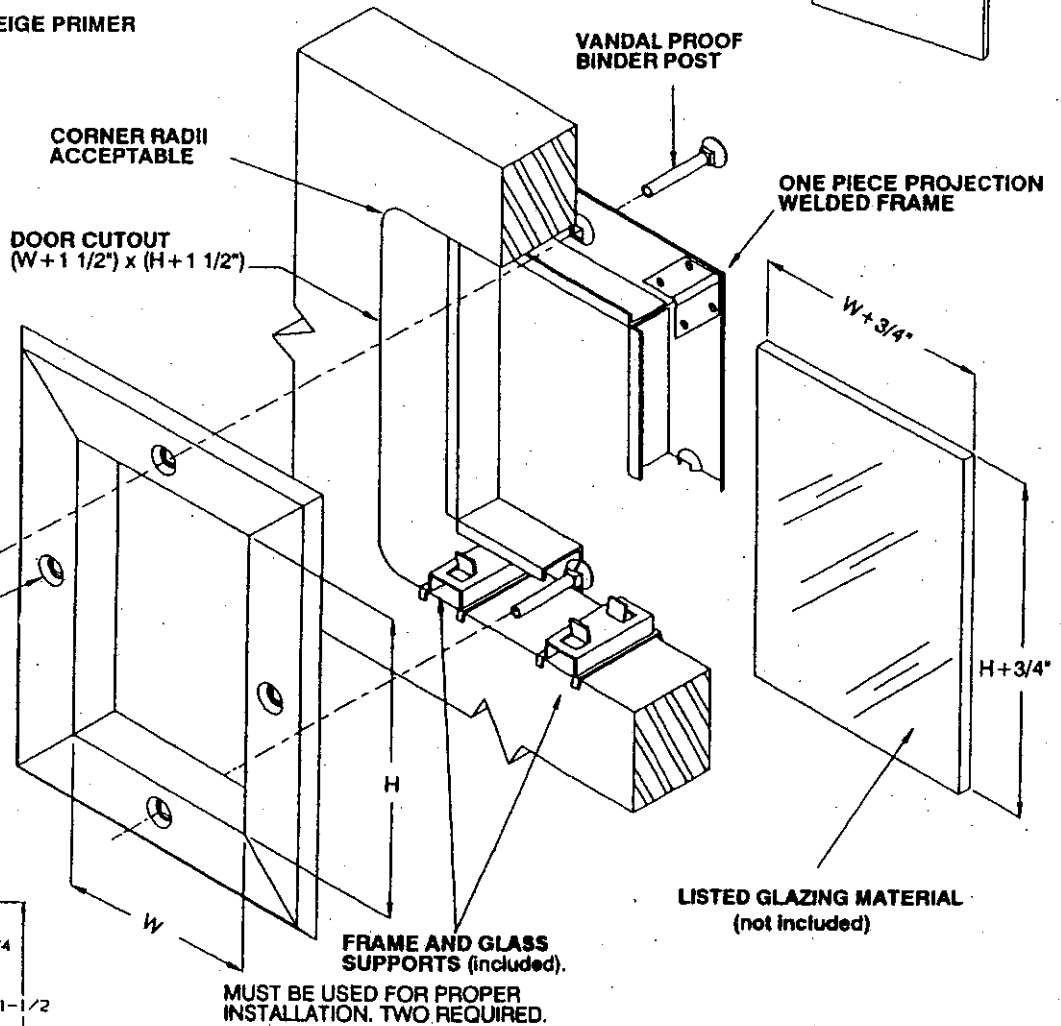

PHILLIPS DRIVE #8-32  
FLAT HEAD SCREW  
INSTALL ON SECURED  
SIDE OF DOOR

MOUNTING HOLES  
11" LENGTH OR LESS:  
1 HOLE CENTERED  
OVER 11":  
3" MAX. FROM CORNERS,  
11-5/16" MAX. CENTERS

LISTED GLAZING MATERIAL  
(not included)

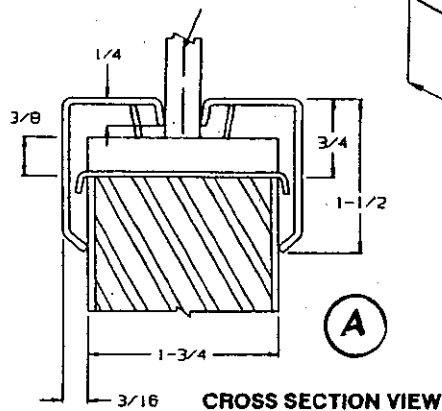

CROSS SECTION VIEW

FRAME AND GLASS  
SUPPORTS (included).

MUST BE USED FOR PROPER  
INSTALLATION. TWO REQUIRED.

LISTED GLAZING MATERIAL  
(not included)

Laminated Glass  
NOT Recommended  
See Glass Note below.

GLASS NOTE: For non-fire door applications we recommend 1/4" tempered glass. If laminated glass is used, thin glazing and light torque on screws is required to prevent glass breakage.

Phone (715) 223-6324

ALL METAL STAMPING, INC.  
411 W. Spruce St., Abbotsford, Wisconsin 54405

FAX (715) 223-3352

23/27

$(A = B + C)$

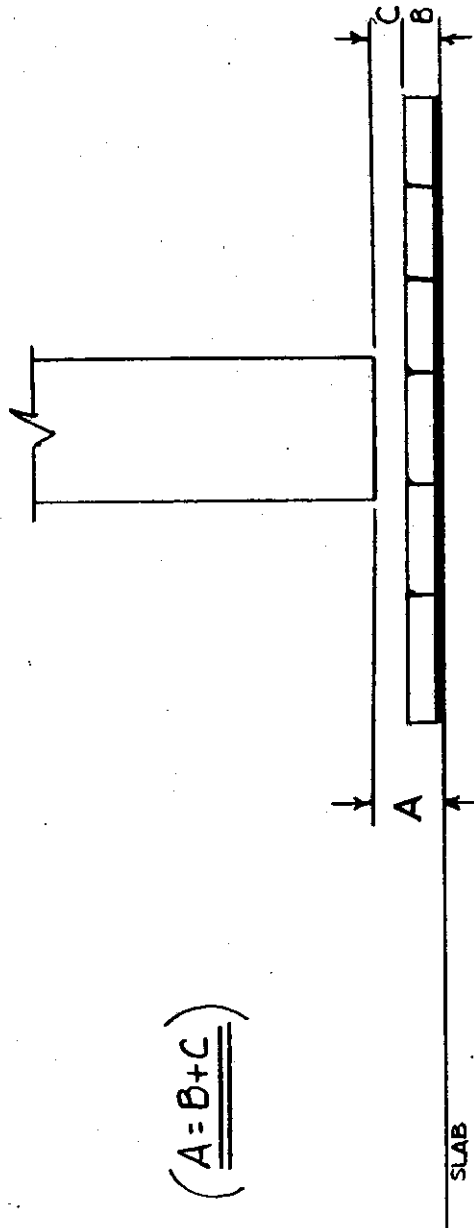

- A. UNDERCUT = DISTANCE FROM BOTTOM OF DOOR TO BOTTOM OF FRAME
- B. FLOOR COVERING TREATMENT = VARIES
- C. CLEARANCE = 1/4" (STANDARD)

PROJECT 1	DATE	DRAWN BY
	REVISIONS	SHEET 24 OF 27

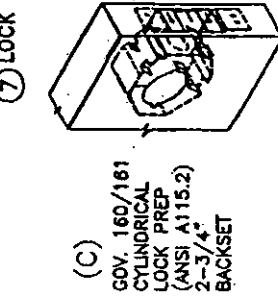
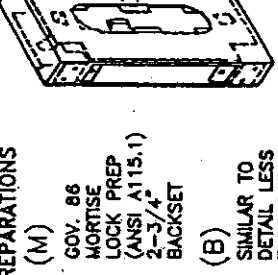
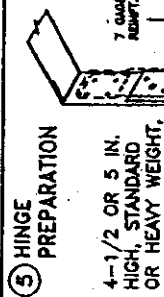
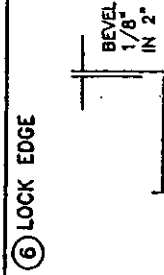
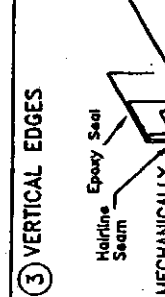
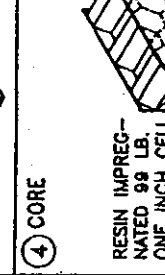
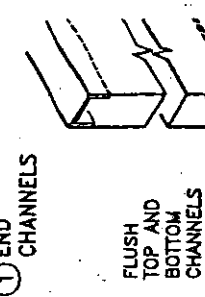
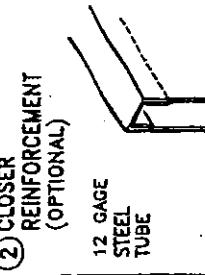

U FACTOR: 0.41  
R FACTOR: 2.44

SOUND TRANSMISSION CLASS (STC): 32 F DESIGN, 18 GAGE FACE SHEETS - - ASTM E90-81 & E413-73 (FULLY OPERABLE)

MEETS OR EXCEEDS ANSI A 151.1 PERFORMANCE TEST:  
20 gage steel (500,000 cycles); 18 & 16 gage steel (1,000,000 cycles).

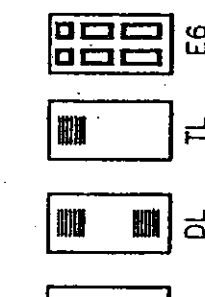

12" x 14-1/2" PIERCED LOUVER

"N" NARROW LITE SIZES ARE AVAILABLE IN 6" AND 8" WIDTHS AND IN 36" TO 60" HEIGHTS, IN 4" INCREMENTS.

EIRE DOORS:  
TEST: UL10B, UL10C  
UBC 7-2

LABELING AGENCIES:  
UNDERWRITERS LABORATORY, INC.  
WARNOCK HERSEY INTL  
FACTORY MUTUAL SYSTEM

RATING: 20 MIN THRU 3 HR  
MAX. SIZE: 40 x 90 SINGLE  
80 x 90 PAIR  
DESIGNS: F, G, N, & V

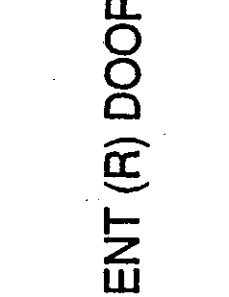
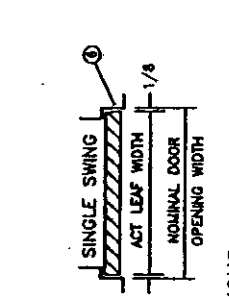
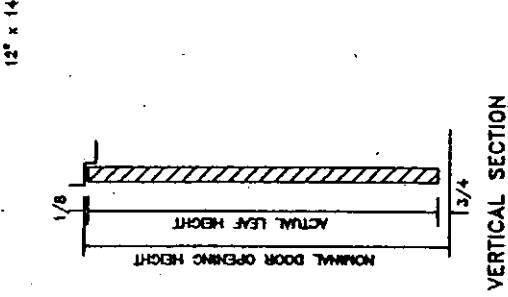

# 1-3/4" REGENT (R) DOOR

**Caco Door Products**  
A United Dominion Company

DRAWN BY \_\_\_\_\_ DATE \_\_\_\_\_  
CHK'D BY \_\_\_\_\_ DATE \_\_\_\_\_

CONTRACT NO. \_\_\_\_\_  
SHT. 25 OF 27  
ISSUE DATE \_\_\_\_\_  
REVISIONS \_\_\_\_\_ BY \_\_\_\_\_

FOR HAND & SWING SEE DOOR SCHEDULE

CORE THERMAL INSULATION  
SOUND TRANSMISSION  
PHYSICAL ENDURANCE TEST DATA

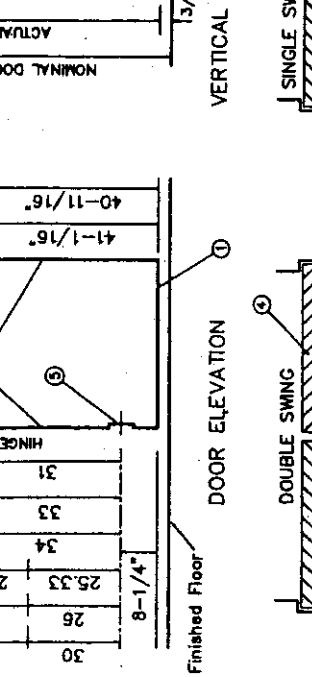
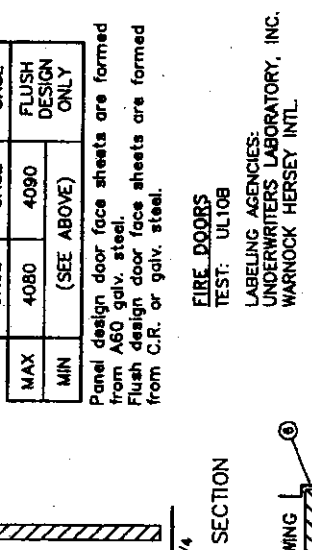
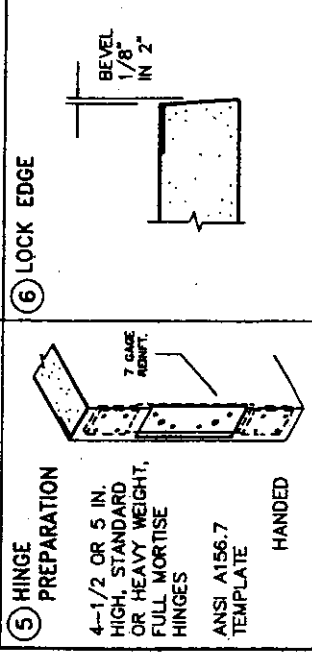
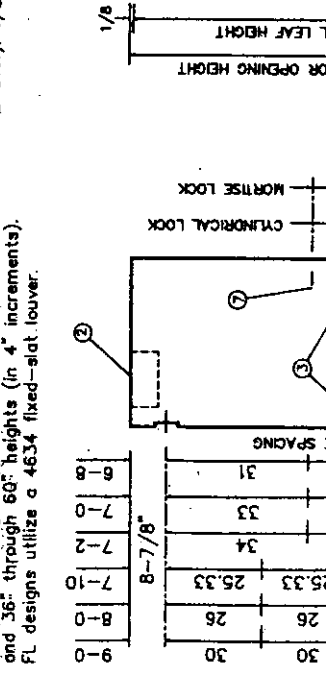
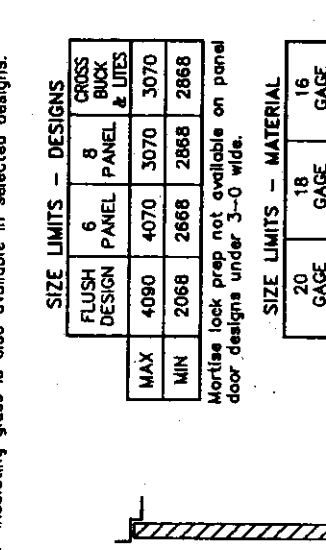
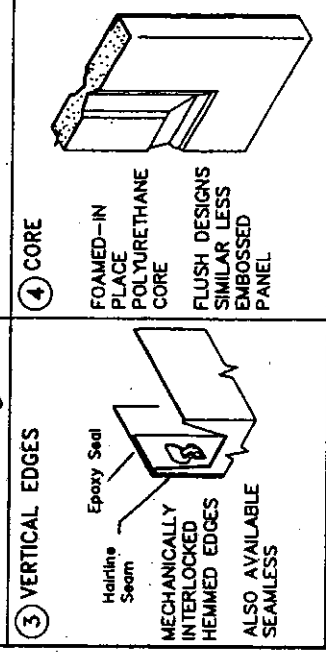
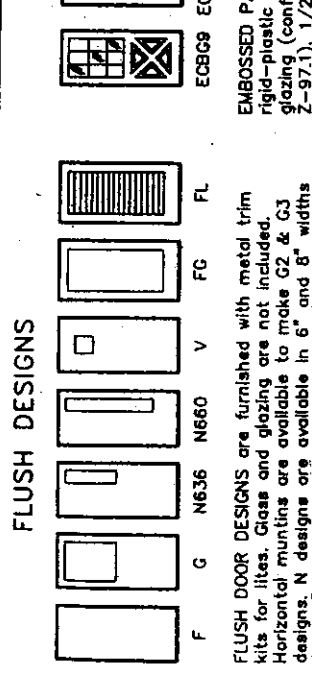
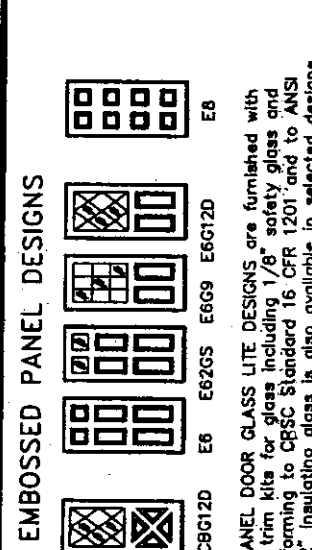
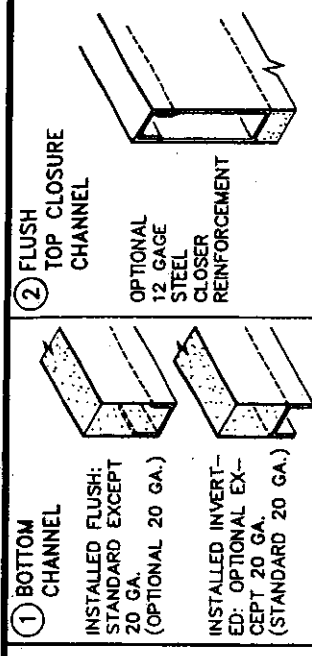

EMBOSSED PANEL DESIGNS

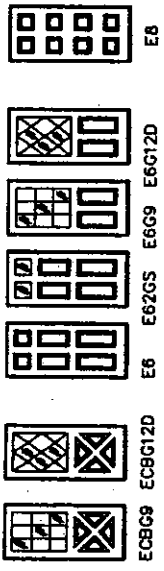

EMBOSSED PANEL DOOR GLASS LITE DESIGNS are furnished with rigid-plastic trim kits for glass including 1/8" safety glass and glazing (conforming to CRSC Standard 16 CFR 1201 and to ANSI Z-97.1). 1/2" insulating glass is also available in selected designs.

SIZE LIMITS - DESIGNS

	FLUSH DESIGN	6 PANEL	8 PANEL	CROSS BUCK PANEL & LITES
MAX	4080	4070	3070	3070
MIN	2088	2868	2868	2868

Mortise lock prep not available on panel door designs under 3-0 wide.

SIZE LIMITS - MATERIAL

	20 GAGE	18 GAGE	16 GAGE
MAX	4080	4090	FLUSH DESIGN ONLY
MIN	(SEE ABOVE)		

Panel design door face sheets are formed from A60 galv. steel.  
Flush design door face sheets are formed from C.R. or galv. steel.

FIRE DOORS

TEST: UL10B  
LABELING AGENCIES:  
UNDERWRITERS LABORATORY, INC.  
WARNOCK HERSEY INTL.  
DESIGNS: F, G, N, V, E6, & E8  
RATING: 20 MIN THRU 1-1/2 HR  
MAX. SIZE:  
(20 GAGE) 40x80 SINGLE  
80x80 PAIR  
RATING: 20 MIN THRU 3 HR  
MAX. SIZE:  
(18 & 16 GAGE) 40x80 SINGLE  
80x80 PAIR

FLUSH DESIGNS

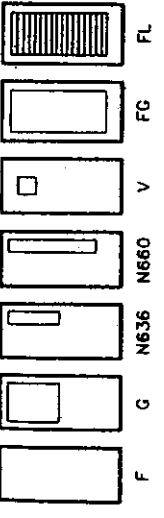

FLUSH DOOR DESIGNS are furnished with metal trim kits for lites. Glass and glazing are not included. Horizontal muntins are available to make G2 & G3 designs. N designs are available in 6" and 8" widths and 36" through 60" heights (in 4" increments). FL designs utilize a 4634 fixed-slat-louver.

1-3/4" IMPERIAL (I)  
EMBOSSED PANEL DESIGNS: 20 or 18 GAGE STEEL  
FULL FLUSH DESIGNS: 20, 18 or 16 GAGE STEEL



DRAWN BY \_\_\_\_\_ DATE \_\_\_\_\_  
CHK'D BY \_\_\_\_\_ DATE \_\_\_\_\_

CONTRACT NO. \_\_\_\_\_  
SHT OF 26 OF 27

FOR GLAZING TRIM OR MATERIALS REQUIRED, SEE DOOR SCHEDULE & ACCESSORY SHEET

REVISIONS BY \_\_\_\_\_

ISSUE DATE \_\_\_\_\_

SEE DOOR SCHEDULE

EDR HAND & SWING

CORE THERMAL INSULATION

SOUND TRANSMISSION

PHYSICAL ENDURANCE TEST DATA

U FACTOR: 0.087  
R FACTOR: 14.97

SOUND TRANSMISSION CLASS (STC): 26 F DESIGN, 18 GAGE FACE SHEETS - - ASTM E90-B1 & E413-73 (FULLY OPERABLE)

MEETS OR EXCEEDS ANSI A 151.1 PERFORMANCE TEST; 20 gage steel (500,000 cycles); 18 & 16 gage steel (1,000,000 cycles).



# Full Mortise Hinges

**Plain Bearing • Standard Weight • Template**  
 For use on Medium Weight Doors Requiring Low Frequency Service  
 (Not for use with Door Closer)

**1279**

Steel with steel pin ANSI A8133

**1191**

Brass with brass pin ANSI A2133

Stainless Steel with stainless steel pin ANSI A5133

Five knuckle non-rising removable pin with button tip and plug.  
 Specify screw requirements.

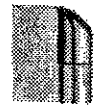
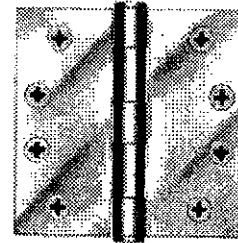

For Hospital type  
 prefix "HT" to  
 catalog number.

Hinge Size		Gauge of metal	Number of holes	Screw Size		Quantity		Avg weight per case (lbs)	
Inches	Millimeters			Machine	Wood	Box	Case	Steel	SSteel/Brass
2 x 2	51 x 51	0.083	4	1/2 x 8-32	3/4 x 8	10 each	200 each	32	35
2 1/2 x 2 1/2	64 x 64	0.089	6	1/2 x 8-32	3/4 x 8	10 each	200 each	34	39
3 x 3	76 x 76	0.097	6	1/2 x 10-24	1 x 9	2 each	100 each	37	40
3 1/2 x 3 1/2	89 x 89	0.119	6	1/2 x 10-24	1 x 9	2 each	100 each	66	72
4 x 4	102 x 102	0.129	8	1/2 x 12-24	1 1/4 x 12	3 each	48 each	43	47
4 1/2 x 4	114 x 102	0.134	8	1/2 x 12-24	1 1/4 x 12	3 each	48 each	49	53
4 1/2 x 4 1/2	114 x 114	0.134	8	1/2 x 12-24	1 1/4 x 12	3 each	48 each	55	60
5 x 4	127 x 102	0.145	8	1/2 x 12-24	1 1/4 x 12	3 each	24 each	37	40
5 x 4 1/2	127 x 114	0.145	8	1/2 x 12-24	1 1/4 x 12	3 each	24 each	37	40
5 x 5	127 x 127	0.145	8	1/2 x 12-24	1 1/4 x 12	3 each	24 each	37	40
6 x 4 1/2	152 x 114	0.160	10	1/2 x 1/4 -20	1 1/2 x 14	3 each	24 each	61	66
6 x 5	152 x 127	0.160	10	1/2 x 1/4 -20	1 1/2 x 14	3 each	24 each	61	66
6 x 6	152 x 152	0.160	10	1/2 x 1/4 -20	1 1/2 x 14	3 each	24 each	61	66

# Ball Bearing • Standard Weight • Template

For use on Medium Weight Doors or Doors Requiring Medium Frequency Service

**BB1279**

Steel with steel pin ANSI A8112

**BB1191**

Brass with brass pin ANSI A2112

Stainless Steel with stainless steel pin ANSI A5112

Five knuckle two ball bearings non-rising removable pin with button tip and plug.  
 Specify screw requirements.

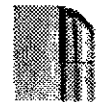
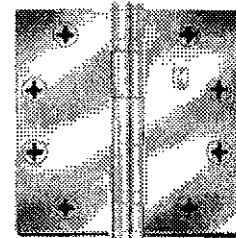

For Hospital type  
 prefix "HT" to  
 catalog number.

Hinge Size		Gauge of metal	Number of holes	Screw Size		Quantity		Avg weight per case (lbs)	
Inches	Millimeters			Machine	Wood	Box	Case	Steel	SSteel/Brass
3 1/2 x 3 1/2	89 x 89	0.119	6	1/2 x 10-24	1 x 9	2 each	100 each	66	72
4 x 4	102 x 102	0.129	8	1/2 x 12-24	1 1/4 x 12	3 each	48 each	43	47
4 1/2 x 4	114 x 102	0.134	8	1/2 x 12-24	1 1/4 x 12	3 each	48 each	55	60
4 1/2 x 4 1/2	114 x 114	0.134	8	1/2 x 12-24	1 1/4 x 12	3 each	48 each	55	60
5 x 4	127 x 102	0.145	8	1/2 x 12-24	1 1/4 x 12	3 each	24 each	37	40
5 x 4 1/2	127 x 114	0.145	8	1/2 x 12-24	1 1/4 x 12	3 each	24 each	37	40
5 x 5	127 x 127	0.145	8	1/2 x 12-24	1 1/4 x 12	3 each	24 each	37	40
6 x 4 1/2	152 x 114	0.160	10	1/2 x 1/4-20	1 1/2 x 14	3 each	24 each	57	62
6 x 5	152 x 127	0.160	10	1/2 x 1/4-20	1 1/2 x 14	3 each	24 each	57	62
6 x 6	152 x 152	0.160	10	1/2 x 1/4-20	1 1/2 x 14	3 each	24 each	57	62

Hinge testing conforms to ANSI A156.1. Furnished with screw hole locations that conform to standards approved by ANSI A156.7.

"THE FIRST FAMILY OF SUPERIOR HARDWARE"

# Full Mortise Hinges

**Ball Bearing • Heavy Weight • Template**  
 For use on Heavy Weight Doors or Doors Requiring High Frequency Service

**BB1168**  
 Steel with steel pin ANSI A8111

**BB1199**  
 Brass with brass pin ANSI A2111  
 Stainless Steel with stainless steel pin ANSI A5111

Five knuckle four ball bearings non-rising removable pin with button tip and plug.  
 Specify screw requirements.

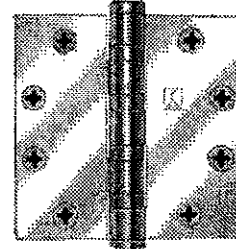

For Hospital type  
 prefix "HT" to  
 catalog number

Hinge Size		Gauge of metal	Number of holes	Screw Size		Quantity		Avg weight per case (lbs)	
Inches	Millimeters			Machine	Wood	Box	Case	Steel	SS/Steel/Brass
4 1/2 x 4	114 x 102	0.180	8	1/2 x 12-24	1 1/4 x 12	3 each	24 each	35	38
4 1/2 x 4 1/2	114 x 114	0.180	8	1/2 x 12-24	1 1/4 x 12	3 each	24 each	35	38
5 x 4	127 x 102	0.190	8	1/2 x 12-24	1 1/4 x 12	3 each	24 each	44	48
5 x 4 1/2	127 x 114	0.190	8	1/2 x 12-24	1 1/4 x 12	3 each	24 each	44	48
5 x 5	127 x 127	0.190	8	1/2 x 12-24	1 1/4 x 12	3 each	24 each	44	48
6 x 4 1/2	152 x 114	.203 Steel & Brass	10	1/2 x 1/4-20	1 1/2 x 14	3 each	24 each	70	65
6 x 5	152 x 127	.190 SS	10	1/2 x 1/4-20	1 1/2 x 14	3 each	24 each	70	65
		.203 Steel & Brass	10	1/2 x 1/4-20	1 1/2 x 14	3 each	24 each	70	65
6 x 6	152 x 152	.190 SS	10	1/2 x 1/4-20	1 1/2 x 14	3 each	24 each	70	65
		.203 Steel & Brass	10	1/2 x 1/4-20	1 1/2 x 14	3 each	24 each	70	65
8 x 6	203 x 152	.190 SS	16	1/2 x 1/4-20	1 1/2 x 14	3 each	12 each	67	62
		.203 Steel & Brass	16	1/2 x 1/4-20	1 1/2 x 14	3 each	12 each	67	62
8 x 8	203 x 203	.190 SS	16	1/2 x 1/4-20	1 1/2 x 14	3 each	12 each	67	62
		.203 Steel & Brass	16	1/2 x 1/4-20	1 1/2 x 14	3 each	12 each	67	62

**Ball Bearing • Heavy Weight • Template • Wide Throw**  
 For use on Heavy Weight door or doors Requiring High Frequency Service

**BB1168 - Wide Throw**  
 Steel with steel pin ANSI A5111

**BB1199 - Wide Throw**  
 Brass with brass pin ANSI A2111  
 Stainless Steel with stainless steel pin ANSI A5111

Five knuckle four ball bearings non-rising removable pin with tip and plug.  
 Specify Screw Requirements.

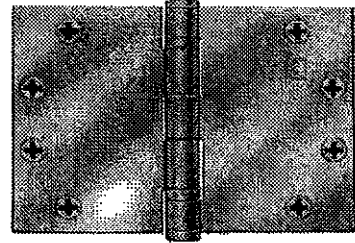

Hinge Size		Gauge of metal	Number of holes	Screw Size		Quantity		Avg weight per case (lbs)	
Inches	Millimeters			Machine	Wood	Box	Case	Steel	SS/Steel/Brass
4 1/2 x 5	114 x 127	0.180	8	1/2 x 12-24	1 1/4 x 12	3 each	24 each	55	60
4 1/2 x 6	114 x 152	0.180	8	1/2 x 12-24	1 1/4 x 12	3 each	24 each	55	60
4 1/2 x 7	114 x 178	0.180	8	1/2 x 12-24	1 1/4 x 12	3 each	24 each	55	60
4 1/2 x 8	114 x 203	0.180	8	1/2 x 12-24	1 1/4 x 12	3 each	24 each	55	60
5 x 6	127 x 152	0.190	8	1/2 x 12-24	1 1/4 x 12	3 each	12 each	32	35
5 x 7	127 x 178	0.190	8	1/2 x 12-24	1 1/4 x 12	3 each	12 each	32	35
5 x 8	127 x 203	0.190	8	1/2 x 12-24	1 1/4 x 12	3 each	12 each	32	35

Hinge testing conforms to ANSI A156.1. Furnished with screw hole locations that conform to standards approved by ANSI A156.7.

Ph. 1-800-325-9995 or 1-314-772-4400 • Fax 1-800-782-0149 or 1-314-772-0744

5A

"THE FIRST FAMILY OF SUPERIOR HARDWARE"





## SPECIFICATIONS - 9K SERIES

**Certifications** - ANSI A156.2, Series 4000 Grade 1 Federal Specifications FF-H-106C/Gen. Listed by Underwriter's Laboratories for use on 3 Hr, A label single swinging doors. GYJT builders hardware single point locks or latches. **Note:** Proper door preparation is mandatory or all warranty and liability for the product is voided.

**Material** - Lever handles are a high-quality zinc alloy. Trim components are brass or bronze. Critical latch and chassis components are brass, corrosion-treated steel, or stainless steel.

Finish - BHMA	US	DESCRIPTION
605	3	Bright Brass
606	4	Satin Brass
611	9	Bright Bronze
612	10	Satin Bronze
613	10B	Oxidized Satin Bronze, Oil Rubbed
618	14	Bright Nickel Plated
619	15	Satin Nickel Plated
622	19	Flat Black
625	26	Bright Chromium Plated
626	26D	Satin Chromium Plated

**Chassis** - 2-1/16" diameter to fit 2-1/8" hole in door (Conforms to ANSI A115.2)

**Lever handles** - Body is approximately 1-5/8" in diameter; Handle is approximately 4-3/4" long (from center-line of chassis). #14 and #15 levers conform to California Administrative Code Title 19 and Title 24. All three styles of levers conform to the Illinois Accessibility Standard.

**Projection on Door** - Approximately 2-3/4" when mounted on 1-3/4" door.

**Roses** - "C"- 3" Convex  
 "D"-3-1/2" Convex  
 "K"-3" Convex - no ring  
 "L"- 3-1/2" Convex - no ring

**Latch** - 9/16" throw. Front 2-1/4" x 1-1/8" beveled. 3/4" throw optional (See Order Procedure below).

**Backset** - 2-3/4" standard, 3-3/4" and 5" available.

**Strike** - STK: Conforms to ANSI A115.3 (2-3/4" x 1-1/8" with curved lip & box). S3: Conforms to ANSI A115.2 for 1-3/4" doors (4-7/8" x 1-1/4" with curved lip).

**Door Thickness** - Available for 1-3/4" to 2-1/4" doors. Spacer available for 1-3/8" doors.

**Mounting** - In addition to standard door preparation (ANSI A115.2 for 1-3/4" doors), two additional holes are needed for thru-bolts. Thru-bolts require two 5/16" diameter holes located at 12 o'clock and 6 o'clock. A drill jig is provided to insure accuracy of the holes. (see page 6B.11).

**Products covered by one or more of the following patents:**

U.S.:			
D290,085	4,437,695	4,428,212	
4,843,852	4,318,558	4,428,570	
4,262,507	4,496,178	4,779,908	
		5,116,170	

**Canada:**  
 1,184,773 1,194,057 1,229,358  
 Other products patent pending.



## ORDER PROCEDURE

### 9K Lever Handle Cylindrical

STEP 1	2	3	4	5	6	7	8
93K	7	AB	14	K	STK	626	
Backset	Core Housing	Function Code	Lever Style	Rose Style	Strike Package	Standard Finishes *	Options
93K-2 3/4" 94K-3 3/4" 95K-5"	O-keyless 7-7 pin housing accepts all Best cores.	AB-corridor D-storeroom L-privacy N-passage R-classroom Etc. page 6B.6-8	14-curved return 15-contour angle return 16-curved no return page 6B.4-5	C- 3"convex D- 3-1/2" convex K- 3"convex - no ring L- 3-1/2" convex - no ring	STK-2-3/4" ANSI S3- 4-7/8" ANSI page 6B.10	605 606 611 612 613 618 619 625 626 (For all available finishes see above)	AL-abrasive lever LL-lead lined SH-security head screws 3/4"-3/4"throw latch NOTE:specify inside (I), outside(O),or both (B) for AL,TL options TL-tactile lever (not available in #15)

\* Handles are made from a zinc alloy, and have been plated to be equivalent in appearance to the finishes listed.

# CYLINDRICALS - LEVERS



## 9K SERIES - FEATURES

### 9K Exploded View

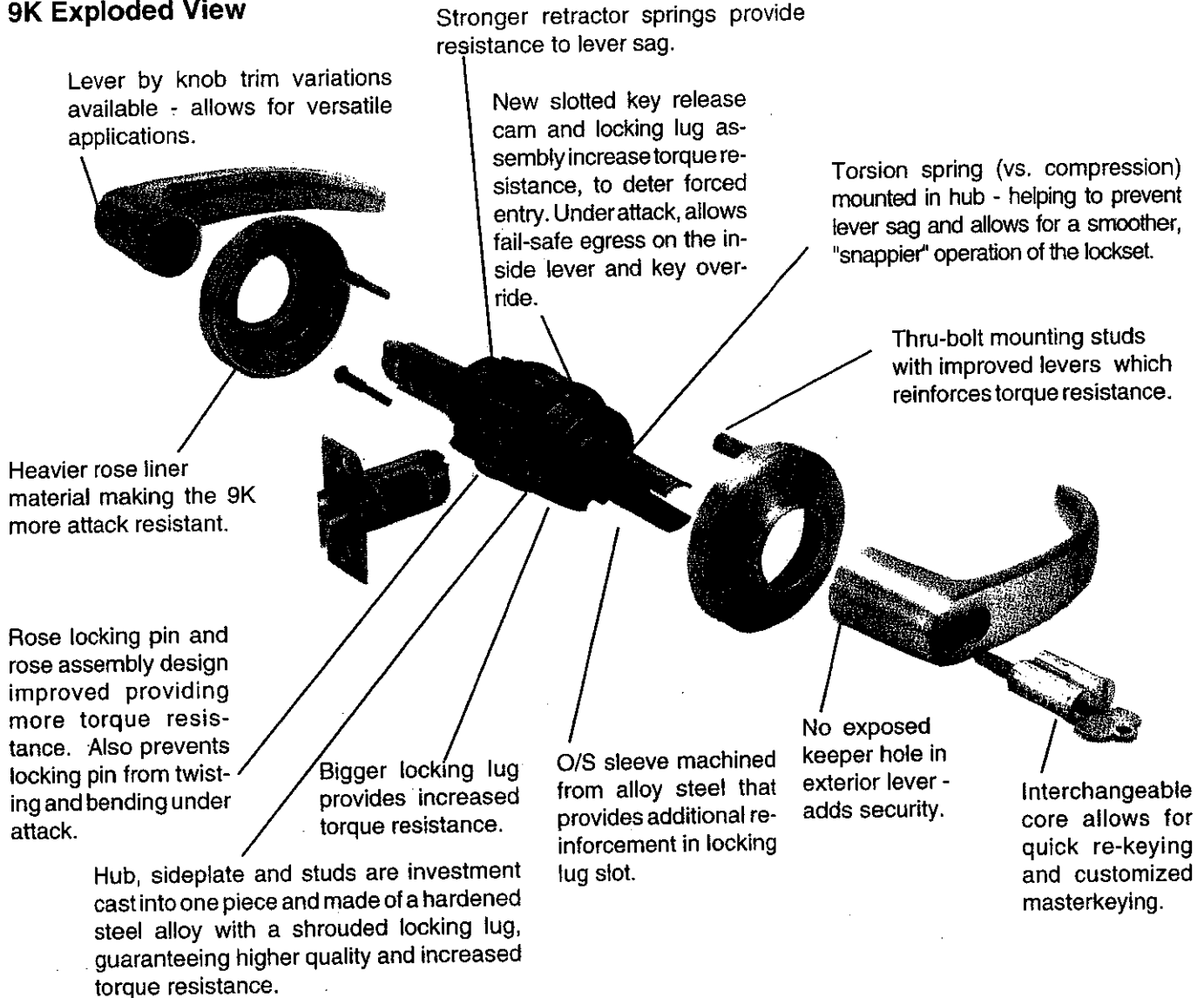

## 9K CYLINDRICAL - OPTIONS

### ABRASIVE LEVERS

Besides complying with a wide variety of handicapped codes and ordinances, Best Lock lever handles are available with a special abrasive feature. Abrasive strip on the lever immediately identifies warnings on doors to hazardous areas for the blind. **TO ORDER:** Designate choice of abrasive lever - AL option on Step 8 of order procedure (page 6B.3).

**Note:** Abrasive strip is available on all levers, however **NOT** on #14 and #16 levers in 613 finish.

### TACTILE LEVERS







Tactile levers may be used in areas where improved grip is required or as a warning in hazardous or safety first areas. Grooves are machined into the back of the hand grasp portion of the lever to improve grip and/or to provide a sensory warning. This option can be used for Blind, Safety, or Handicapped applications. **TO ORDER:** Designate "TL" on step 8 of order procedure (page 6B.3).

**Note:** The (TL) option will be available on #14 and #16 levers in all finishes. The (TL) option will **NOT** be available

# CYLINDRICALS - LEVERS

## 9K SERIES - FUNCTION DESCRIPTIONS

### Single keyed functions

Function & Diag. (ANSI No.)		Description	Outside lever		Inside lever	
		Latch operated by	locked by	unlocked by	locked by	unlocked by
AB F81	 <b>Corridor lock</b>	<ul style="list-style-type: none"> <li>Rotating the inside lever, <b>OR</b></li> <li>Rotating the outside lever—only when the inside push button is out.</li> </ul>	<ul style="list-style-type: none"> <li>Pushing the inside button, <b>QB</b></li> <li>Pushing and turning the inside button. Turning the button keeps the outside lever locked until the button is turned back.</li> </ul>	<ul style="list-style-type: none"> <li>Turning the key in the outside lever, <b>QB</b></li> <li>Rotating the inside lever, <b>OR</b></li> <li>Closing the door.</li> </ul>	Cannot be locked	Always unlocked
D F86	 <b>Storeroom Lock</b>	<ul style="list-style-type: none"> <li>Turning the key in the outside lever, <b>QB</b></li> <li>Rotating the inside lever.</li> </ul>	Always fixed	Cannot be unlocked	Cannot be locked	Always unlocked
E F92	 <b>Service Station Lock</b>	<ul style="list-style-type: none"> <li>Rotating the inside lever, <b>OR</b></li> <li>Rotating the outside lever—only when the inside push button is out.</li> <li>Turning the key in the outside lever.</li> </ul>	<ul style="list-style-type: none"> <li>Pushing the inside button, <b>QB</b></li> <li>Pushing and turning the inside button. Turning the slotted button keeps the outside lever locked until the button is turned back.</li> </ul>	<ul style="list-style-type: none"> <li>Turning the key in outside lever, <b>QB</b></li> <li>Rotating the inside lever, <b>OR</b></li> <li>Closing the door, only when the slotted push button is unlocked.</li> <li>Turning the slotted button back.</li> </ul>	Cannot be locked	Always unlocked
H F93	 <b>Hotel Guest Room Lock</b>	<ul style="list-style-type: none"> <li>Rotating the inside lever, <b>OR</b></li> <li>Turning the key in the outside lever—only when the inside push button is out, <b>QB</b></li> <li>Removing the core with a control key and using a special emergency key.</li> </ul>	Always fixed	Key block feature is released by: <ul style="list-style-type: none"> <li>Rotating the inside lever, <b>OR</b></li> <li>Closing the door.</li> </ul>	Cannot be locked	Always unlocked
*Pushing the inside button displays an "occupied" indicator in the outside lever and blocks all operating keys.						
HJ	 <b>Hotel Guest Room Lock</b>	<ul style="list-style-type: none"> <li>Rotating the inside lever, <b>OR</b></li> <li>Turning the key in the outside lever—only when the inside push button is out, <b>QB</b></li> <li>Removing the core with a control key and using a special emergency key.</li> </ul>	Always fixed	Key block feature is released by: <ul style="list-style-type: none"> <li>Rotating the inside lever, <b>OR</b></li> <li>Closing the door.</li> </ul>	Cannot be locked	Always unlocked
*Pushing the inside button blocks all operating keys, but no "occupied" indicator is displayed.						
R F84	 <b>Classroom Lock</b>	<ul style="list-style-type: none"> <li>Rotating the inside lever, <b>OR</b></li> <li>Turning the key in the outside lever, <b>QB</b></li> <li>Rotating the outside lever when not locked by key.</li> </ul>	Turning the key in the outside lever.	Turning the key in the outside lever.	Cannot be locked	Always unlocked
T F90	 <b>Dormitory Lock</b>	<ul style="list-style-type: none"> <li>Rotating the inside lever, <b>OR</b></li> <li>Rotating the outside lever when not locked by key or push button.</li> </ul>	<ul style="list-style-type: none"> <li>Turning the key in the outside lever, <b>QB</b></li> <li>Pushing the button on the inside lever.</li> </ul>	<ul style="list-style-type: none"> <li>Turning the key in the outside lever, <b>QB</b></li> <li>Rotating the inside lever (only when locked by push button), <b>OR</b></li> <li>Closing the door (only when locked by push button).</li> </ul>	Cannot be locked	Always unlocked

### Double keyed functions\*

C F88	 <b>Corridor lock</b>	<ul style="list-style-type: none"> <li>Rotating the inside lever, <b>QB</b></li> <li>Rotating the outside lever when not locked by key, <b>OR</b></li> <li>Turning the key in the outside lever.</li> </ul>	Turning the key in the inside lever.	Turning the key in the inside lever.	Cannot be locked	Always unlocked
----------	---	---	--------------------------------------	--------------------------------------	------------------	-----------------

\* **WARNING:** Locksets that secure both sides of the door are controlled by building codes and the Life Safety Code. In an



# 9K SERIES FUNCTIONS

Function & Diag. (ANSI No.)	DESCRIPTION	Outside lever		Inside lever	
		locked by	unlocked by	locked by	unlocked by
<b>G</b> F91 	<b>Storeroom Lock</b> <ul style="list-style-type: none"> <li>Rotating the outside lever when not locked by key, <b>OR</b></li> <li>Rotating the inside lever when not locked by key.</li> </ul>	<ul style="list-style-type: none"> <li>Turning the key in the inside lever, <b>OR</b></li> <li>Turning the key in the outside lever.</li> </ul>	<ul style="list-style-type: none"> <li>Turning the key in the inside lever, <b>OR</b></li> <li>Turning the key in the outside lever.</li> </ul>	<ul style="list-style-type: none"> <li>Turning the key in the inside lever, <b>OR</b></li> <li>Turning the key in the outside lever.</li> </ul>	<ul style="list-style-type: none"> <li>Turning the key in the inside lever, <b>OR</b></li> <li>Turning the key in the outside lever.</li> </ul>
*Turning the key in either the inside <b>OR</b> the outside, locks or unlocks both sides.					
<b>S</b> F80 	<b>Communicating Lock</b> <ul style="list-style-type: none"> <li>Turning the key in the inside lever, <b>OR</b></li> <li>Turning the key in the outside lever.</li> <li>Turning the inside or outside lever (if unlocked)</li> </ul>	Turning the key in the outside lever.	Turning the key in the outside lever.	Turning the key in the inside lever.	Turning the key in the inside lever.
*Turning the key in either lever, locks or unlocks its own lever independently.					
<b>W</b> F87 	<b>Institutional Lock</b> <ul style="list-style-type: none"> <li>Turning the key in the inside lever, <b>OR</b></li> <li>Turning the key in the outside lever.</li> </ul>	Always fixed	Cannot be unlocked	Always fixed	Cannot be unlocked

## Keyless functions

<b>L</b> F76 	<b>Privacy lock</b> <ul style="list-style-type: none"> <li>Rotating the inside lever, <b>OR</b></li> <li>Rotating the outside lever only when the inside push button is out.</li> </ul>	Pushing the inside button	Rotating the outside slotted lever, <b>OR</b> rotating the inside lever, <b>OR</b> pushing the inside button	Cannot be locked	Always unlocked
<b>N</b> F75 	<b>Passage Lock</b> <ul style="list-style-type: none"> <li>Rotating the inside lever, <b>OR</b></li> <li>Rotating the outside lever.</li> </ul>	Cannot be locked	Always unlocked	Cannot be locked	Always unlocked
<b>NX</b> F75 	<b>Exit Lock</b> <ul style="list-style-type: none"> <li>Rotating the inside lever.</li> </ul>	Always fixed	Cannot be unlocked	Cannot be locked	Always unlocked
<b>P</b> F77 	<b>Patio Lock</b> <ul style="list-style-type: none"> <li>Rotating the inside lever, <b>OR</b></li> <li>Rotating the outside lever—only when the inside push button is out.</li> </ul>	Pushing the inside button	Rotating the inside lever, <b>OR</b> pushing the inside button	Cannot be locked	Always unlocked
<b>Y</b> 	<b>Exit Lock</b> <ul style="list-style-type: none"> <li>Rotating the inside lever.</li> </ul>	Always fixed	Cannot be unlocked	Cannot be locked	Always unlocked

**1DT** **Single Dummy Trim** This is a single, surface-mounted lever for an inactive door or a non-latching door.



**2DT** **Double Dummy Trim** This is a thru-bolt mounted pair of matching levers for an inactive door or a non-latching door.



**9K SERIES - TRIM VARIATIONS**

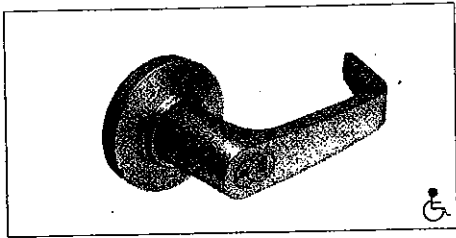

**15C**

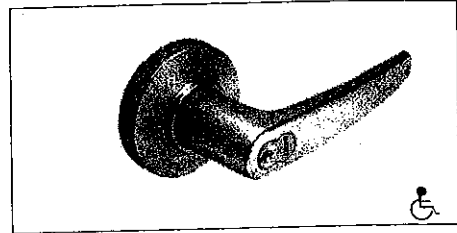

**16C**

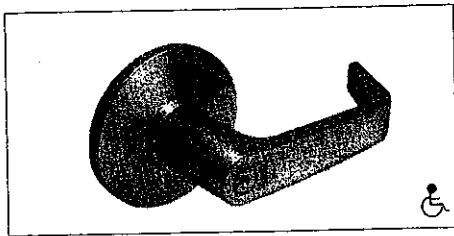

**15D**

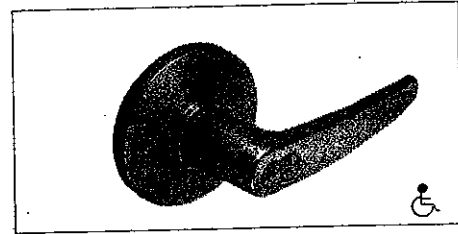

**16D**

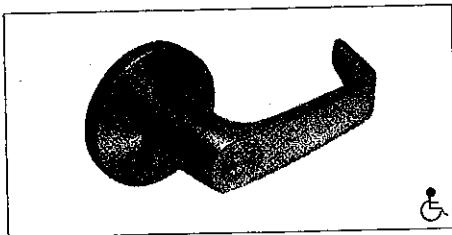

**15K**

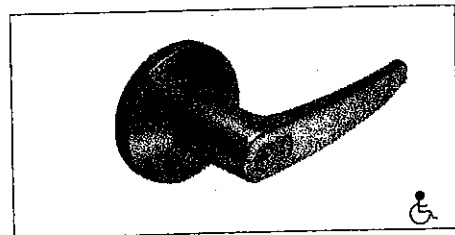

**16K**

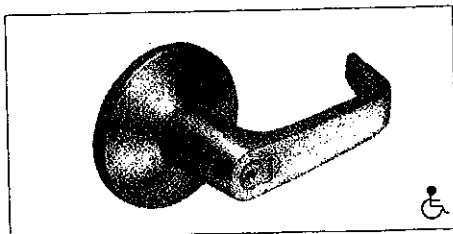

**15L**

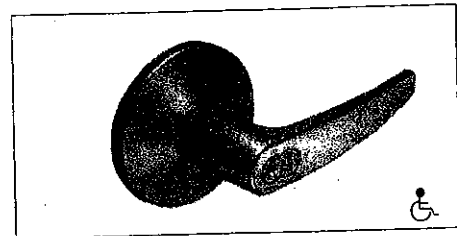

**16L**

# CYLINDERS

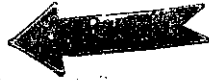

## 1E SERIES - CYLINDERS

### 1E MORTISE CYLINDER

Standard mortise applications require use of Best's 1E Series cylinders with standard 1E-C4 cam. Best cylinders may be altered to function with other manufacturers' locks by use of different cams (see page 9.8) and different cylinder rings (see page 9.9).

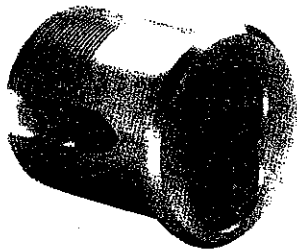

Special cylinder variations are available for most applications (see pages 9.4 & 9.5).

Best cylinders are machined from brass or bronze bar stock and are available in a variety of finishes. Additional security is provided by a set screw that mounts diagonally in the cylinder wall and when tightened, holds the cylinder securely in the housing. Best mortise cylinders feature the Best interchangeable core and may be masterkeyed into any existing Best system. Contact your local Best Representative for information on special cylinder applications not listed in this catalog.

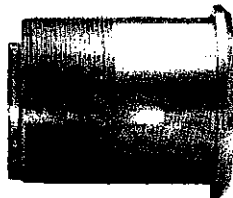

#### SPECIFICATIONS

CYLINDER NOMENCLATURE	DIMENSION "A"	DOOR THICKNESS
1E-64	1-1/8"	1-5/8" to 2-1/4"
1E-74	1-1/4"	1-7/8" to 2-1/2"

CYLINDER DIAMETER - 1-5/32"

To Order: see below. Example: 1E74-C4-RP3-626

Products covered by one or more of the following patents.

4,437,695                      4,633,690                      4,616,394

#### HOW TO ORDER:

STEP: A	B	C	D	E	F	G	H	
1E	7	4		C4	RP3	626		**
CYLINDER DIAMETER	CORE HOUSING	FUNCTION CODE	STANDARD MORTISE LENGTH CODE	CAM OR SPINDLE	RINGS	STANDARD FINISHES	OPTIONS	
1E-1-5/32"	0-dummy	2-rim	Blank-standard	C4-standard cam	RP-rim cylinder	605 606	MC-marine	
3E-1-1/2"	6-6 pin	4-mortise*	22-1-3/8"	C181-Adams Rite	RP1-tapered cyl.	612 613	construction	
5E-see page 9.10	7-7 pin housing	6-tapered mortise	24-1-1/2" etc. up to 96'-6"	MS cam	RP2-6 pin mortise	625 626		
8E-see page 9.7	accepts all Best cores		(see page 9.4 and 9.5)	S2-standard spindle (special cams see page 9.8)	RP3-7 pin mortise RP4-3E mortise (special rings-see page 9.9)		Specify hand if required	

\* For additional special mortise cylinders, see pages 9.4 and 9.5.

\*\* Must specify keymark and number of keys or designate L/C for less core.

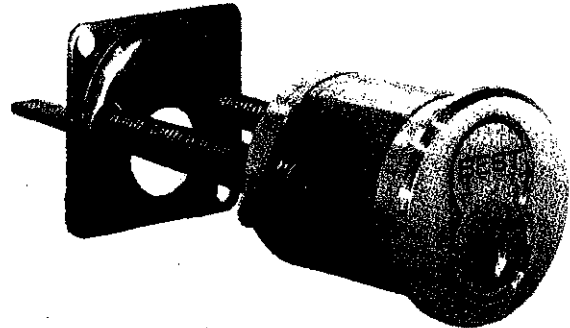

### 1E RIM CYLINDER

Standard rim cylinder applications require the use of Best's 1E rim cylinder series. Best rim lock cylinders are interchangeable with other manufacturers' rim locks. Best rim cylinders are machined from solid bar stock and are available in a variety of finishes. The standard package for the Best rim cylinder includes cylinder, 1E-R3 and 1E-R5 rings, 1E-S2 spindle, clamp plate and clamp plate screws. Best rim cylinders feature the Best interchangeable core and may be masterkeyed into any existing Best system.

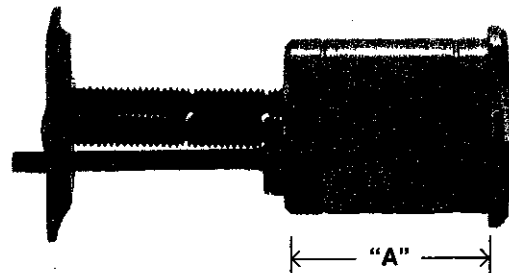

#### SPECIFICATIONS

CYLINDER NOMENCLATURE	DIMENSION "A"	DOOR THICKNESS
1E-62	1-3/16"	1" to 2-3/4"
1E-72	1-11/32"	1-1/4" to 3"

CYLINDER DIAMETER- 1-5/32"

To Order: see page 9.2 example: 1E72-S2-RP-626

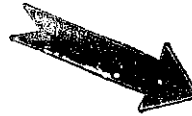

# 6000 SERIES PUSH-PULL LATCH

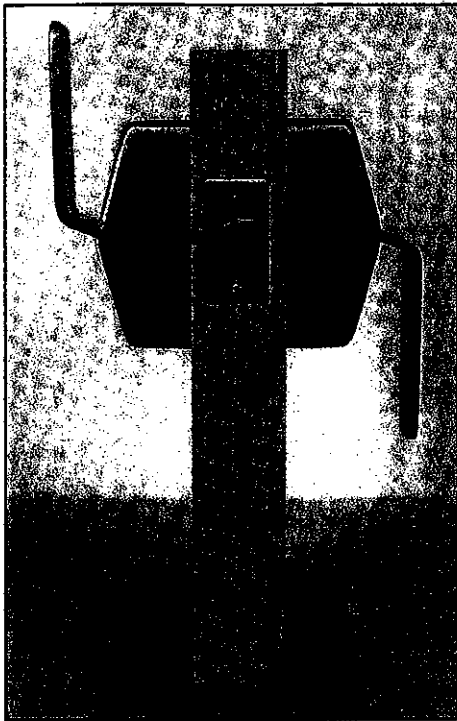

- Non-handed (except for engraved models). **SEE NOTE BELOW.\***
- Push/pull latch can be mounted with the handles up, down or horizontal without any modification.
- Available with 2 3/4", 5" or 7" backset latches.
- Standard or ASA strike.
- Includes all required fasteners.
- Compact non-handed covers provide maximum clearance between the handle and door.
- UL listed for all fire doors.
- Available in BHMA finishes.
- Lead lining is available.
- Available latch bracket for Roller to Push Pull conversion.
- Meets ADA requirements.

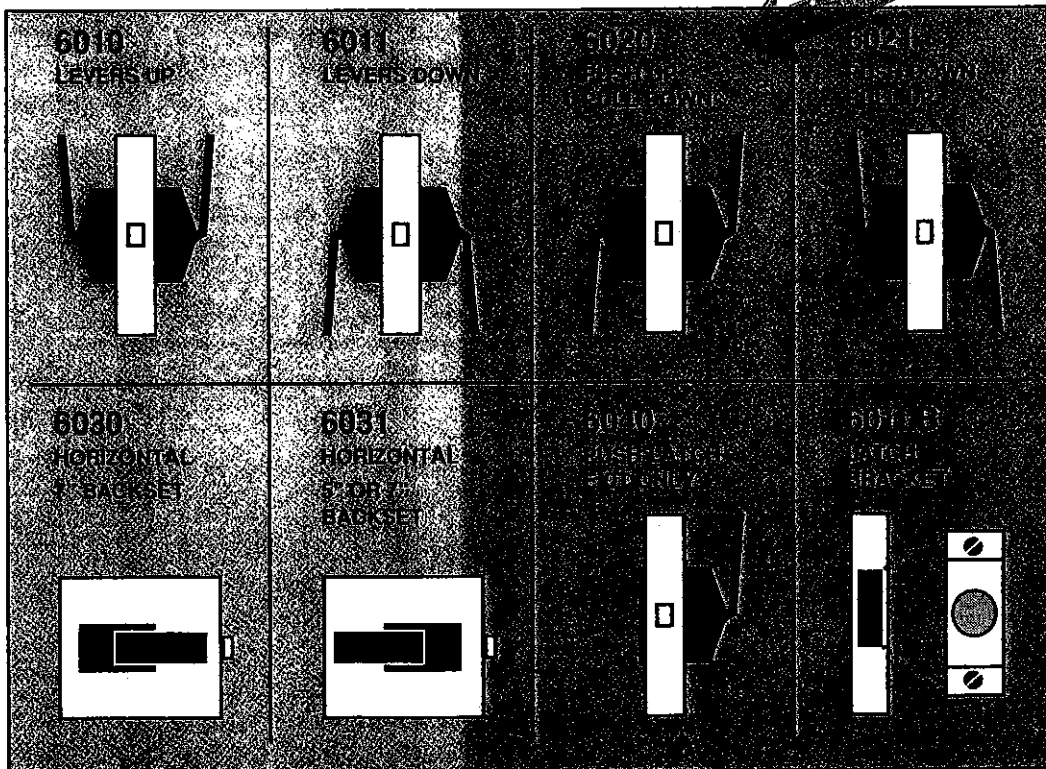

\* When ordering engraved models, add the letter **P** after the numbers shown below and designate hand.

Visit our web site at <http://www.abhmfg.com>  
**Architectural Builders Hardware Mfg., Inc.**  
 500 Crossen Ave.  
 Elk Grove Village, IL 60007  
 847.437.9901; FAX 800.9FAXABH (932.9224)

ABH is a minority owned and operated manufacturing company

© 1997 ABH Mfg., Inc.  
 Printed in USA 397



# 6000 SERIES PUSH/PULL LATCH

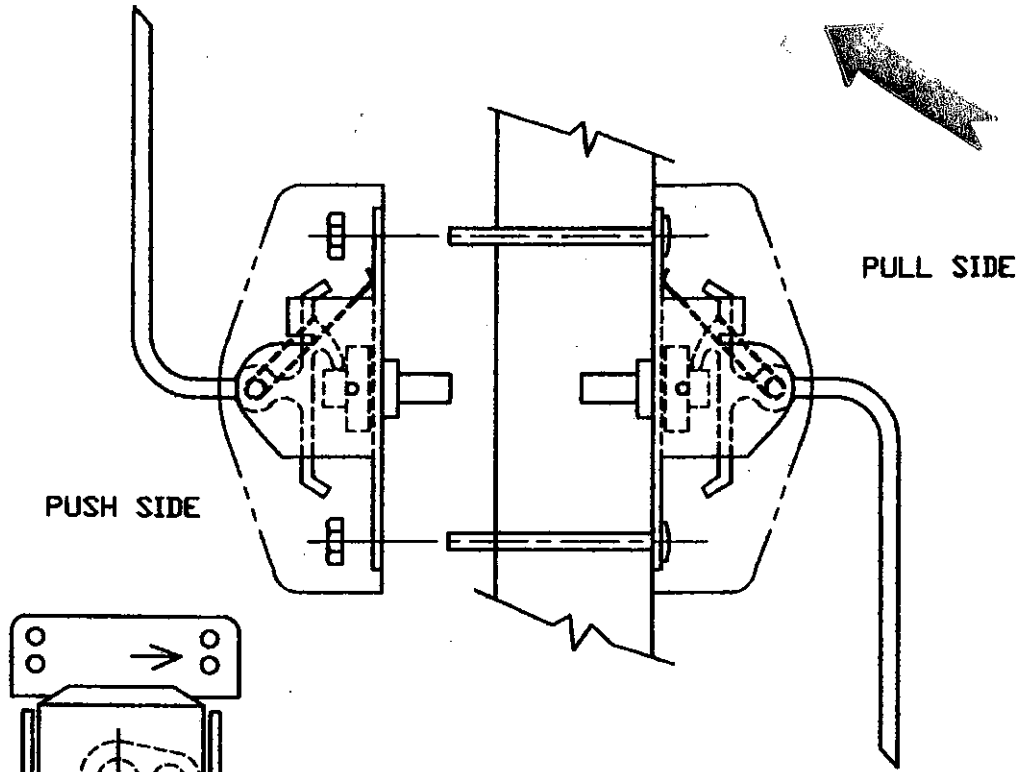

**NOTE:**  
 BEFORE MOUNTING PUSH AND PULL HANDLES,  
 CAM PIN MUST BE ROTATED TOWARD SIDE INDICATED  
 BY ARROW STAMPED ON BASE

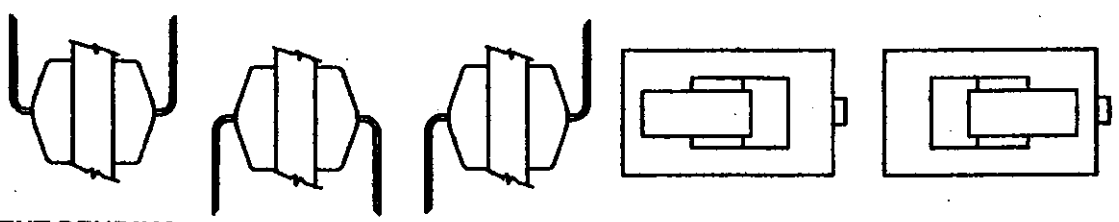

PATENT PENDING

SCREW DETAIL		
	WOOD DOOR	METAL DOOR
PUSH/PULL HANDLE	(4) 10-32 X 2-3/4" PAN HD. M.S. (4) 10/32 NUT	(4) 10-32 X 2-3/4" PAN HD. M.S. (4) 10/32 NUT
COVER	(4) 8-32 x 3/8" F.H.M.S.	(4) 8-32 x 3/8" F.H.M.S.
LATCH	(2) #6 X 3/4" F.H.W.S.	(2) 6-32 x 3/8" F.H.M.S.
STD STRIKE	(2) #8 X 3/4" F.H.W.S.	
ASA STRIKE		(2) 12-24 X 3/8" F.H.M.S.

Visit our web site at <http://www.abhmfg.com>  
**Architectural Builders Hardware Mfg., Inc.**  
 500 Crossen Ave.  
 Elk Grove Village, IL 60007  
 847.437.9901; FAX 800.9FAXABH (932.9224)

ABH is a minority owned and operated manufacturing company  
 © 1997 ABH Mfg., Inc.  
 Printed in USA 397





# VON DUPRIN® 98/99 Rim Devices

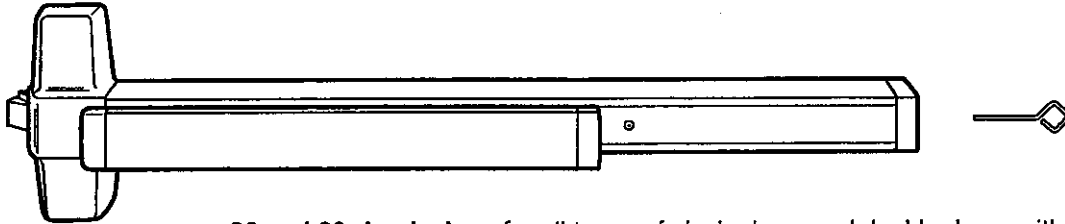

**98 and 99 rim devices** for all types of single doors and double doors with mullion, UL listed for accident hazard installations. Covers stock hollow metal doors with 86 or 161 cutouts.



## FEATURES

- Nonhanded
- Field sizeable
- $\frac{3}{4}$ " (19mm) throw, latch bolt
- Latch bolt deadlocking
- Eight popular finishes
- Hex key dogging

## DIMENSIONS

Touchbar height to finished floor	$39\frac{13}{16}$ " (935mm) at center
Touchbar projection —	
neutral	$3\frac{13}{16}$ " (97mm)
depressed	$3\frac{1}{8}$ " (78mm)
Center case	$8" \times 2\frac{1}{4}" \times 2\frac{3}{4}"$ (203mm $\times$ 57mm $\times$ 70mm)
Device length — Short 3'	2'6" to 3' (762mm to 914mm) door size
Long 4'	3'1" to 4' (940mm to 1219mm) door size

## OUTSIDE TRIM

### Standard

990NL-R/V  
990TP-R/V  
990DT  
110NL-MD  
991K-R/V  
992L-R/V

### Optional

990EO  
696NL-R/V  
696TP-R/V  
696DT  
697NL-R/V  
697TP-R/V  
697DT  
KP992L-R/V  
994L-R/V  
110NL-WD  
392-7

For complete outside trim information, see pages 18-19.

## STRIKES AND FASTENERS

Device is furnished with standard 299 strike in dull black finish. All necessary fasteners are included. Optional strikes and finishes are available. For strike applications, dimensions, and minimum door stile information refer to pages 22, 23.

A combination of fasteners are included for surface mounting and through bolting to trim on  $1\frac{3}{4}$ " (44mm) and  $2\frac{1}{4}$ " (57mm) thick doors.

## DEVICE OPTIONS

Electric latch retraction, page 24  
Pneumatic latch retraction, page 27  
Electric rim device, page 25  
Request to exit switch, page 26  
Latch bolt monitoring, page 26  
Signal switch, page 26  
Cylinder dogging, page 30  
Double cylinder, page 27

For How-To-Order Information on all devices, see page 35.



# VON DUPRIN®

## 98/99 Additional Information

### NOMENCLATURE

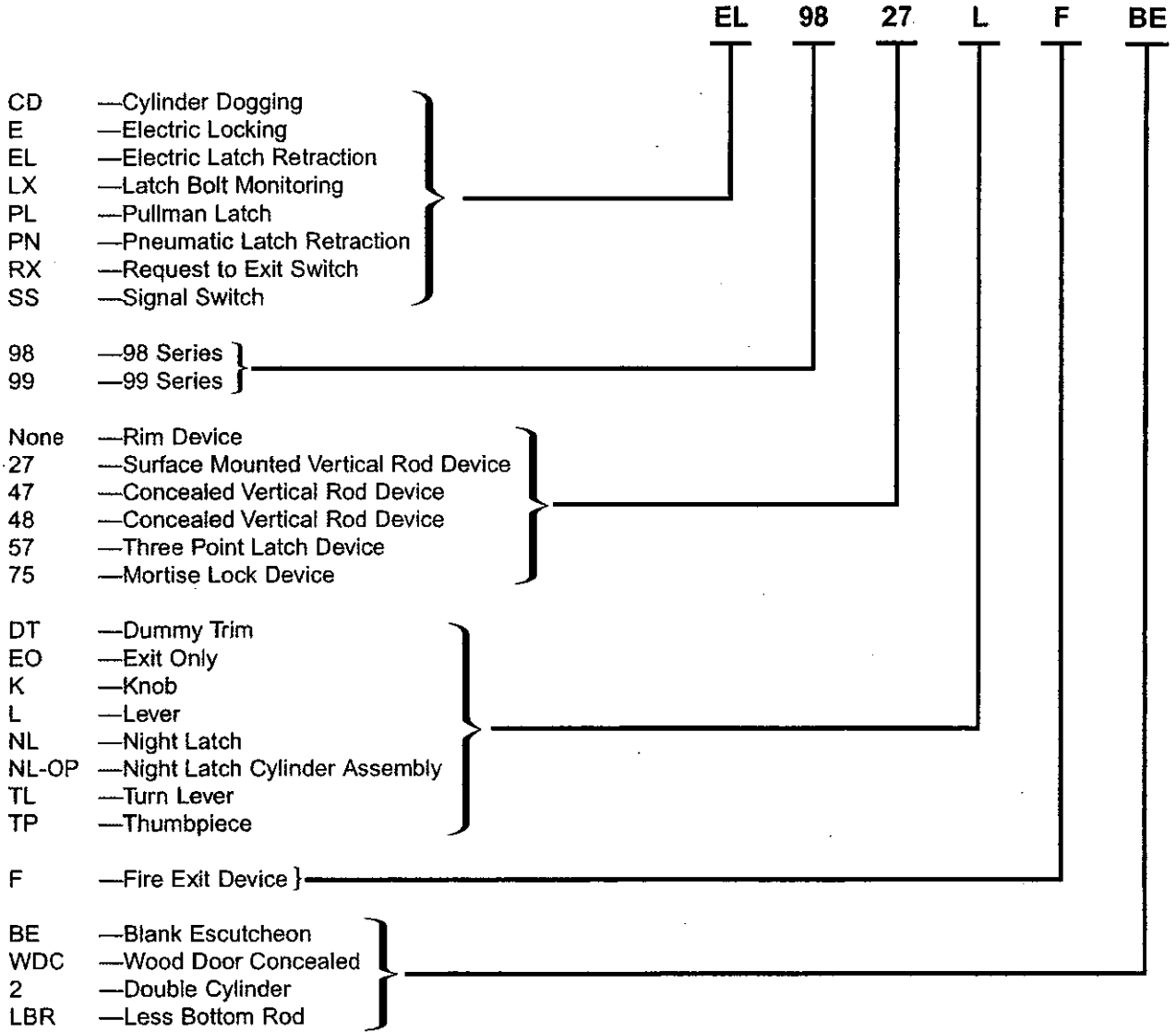

# VON DUPRIN®

## 98/99 Additional Information

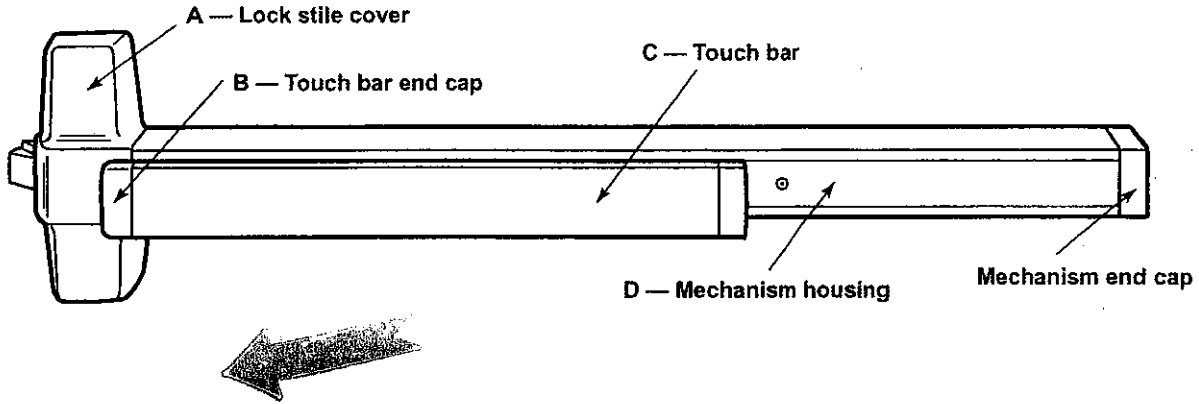

### FINISHES

Color*	US Number	BHMA Number	A, B, E	C	D
Brass, Polished	US3	BHMA605	Plated	Brass, Polished US3, BHMA605	Buffed Anodized
Brass, Satin	US4	BHMA606	Plated	Brass, Dull US4, BHMA606	Anodized
Bronze, Satin	US10	BHMA612	Plated/Anodized Bronze, Dull US10, BHMA612		Anodized
Chrome, Polished	US26	BHMA625	Plated	Stainless Steel, Polished US32, BHMA629	Buffed Anodized
Chrome, Satin	US26D	BHMA626	Plated	Stainless Steel, Satin US32D, BHMA630	Anodized
Stainless Steel, Satin	US32D	BHMA630	Stainless Steel	Stainless Steel, Satin US32D, BHMA630	Anodized
Aluminum, Anodized	US28	BHMA628	Painted	Stainless Steel, Satin US32D, BHMA630	Anodized
Duranodic Dark Bronze	313	—	Painted	Wood grain vinyl**	Anodized

**Touch Bar Options.** — Knurled — Black vinyl — Walnut grain vinyl — Embossed "Push", brass, bronze or stainless steel

\*US32D Finish — available on Series 98, consult factory.

\*\*US10B available, consult factory.

# VON DUPRIN® 98/99 Accessories

## DUMMY PUSH BAR



The 330 grooved and 350 smooth dummy push bars are designed as a companion unit for all 98 or 99 devices. The touch bar is rigid and non-functioning. A push/pull operation can be accomplished by using 990DT, 696DT, or 697DT trim.

### To order, specify:

1. 330 or 350.
2. Size, 3' or 4' (914mm or 1219mm).
3. Finish, see page 35.

## CYLINDER DOGGING — CD



Cylinder dogging is available on all 98/99 devices to replace the standard hex key dogging. Furnished, not installed. Unit requires a standard 1 1/4" (32mm) mortise cylinder.

### To order, specify:

1. Prefix CD, example CD99NL.

## CYLINDER DOGGING KIT — CDK

For field conversion, a cylinder dogging conversion kit is available. Order: 33/99CDK or 35/98CDK, specify finish.

## HEX KEY DOGGING KIT — HDK

For field conversion, a hex key dogging conversion kit is available. Order: 33/99HDK or 35/98HDK, specify finish.

## GLASS BEAD KIT

Glass bead conversion kits are available for all 99 Series devices for use on doors with raised glass beads. Each kit consists of 1/4" (6mm) shim sets.

### To order, specify:

1. 99GBK.
2. Device type (rim, mortise, surface vertical and concealed vertical rod.)
3. Wood door, when used with concealed vertical.

## COVER PLATES KIT — 997 KIT

For 99 rim device, kit contains inside and outside plates for hinge stile cutouts, an inside plate for the lock stile, and necessary screws. Plates are designed to cover cutouts required by most existing exit device installations. Specify finish.

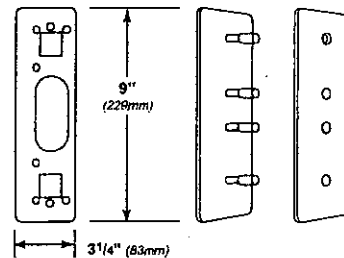

## CYLINDERS

Cylinders are not furnished with device or trim and must be specified when ordering. Rim, surface vertical rod, and concealed vertical rod exit devices use rim type cylinders. Mortise lock exit devices and series 370 controls use mortise type cylinders.

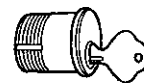

Mortise - 3215 (Schlage B502-191 cam)

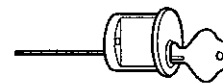
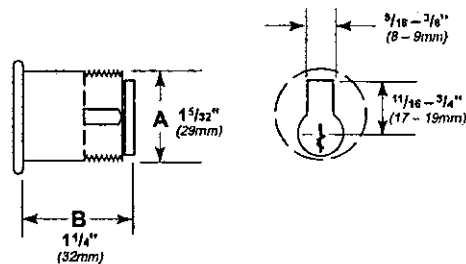

Rim - 3216

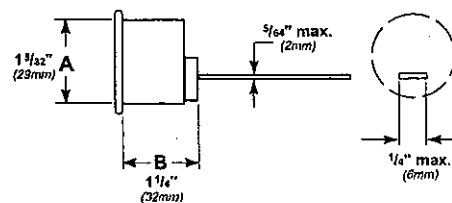

**SUPER SMOOTHEE®  
SURFACE MOUNTED CLOSER**

Specify finish (F), hand (H), size (S), and cylinder function (C) where indicated.

**CYLINDER**

4040-3071                      Cylinder Assembly                      F,S,C  
 SIZE: 1  
 4041-3071 cylinder adjustable from size 1 thru 6.  
 CYLINDER FUNCTION: Regular, Delay.  
 -3071 regular cylinder provides all normal functions.  
 -3071DA cylinder provides delayed closing action from maximum opening until approximately 70°.

**INDIVIDUAL PARTS**

Parts for 4040-72	Cover	
Parts for 4040-72LL	Lead Lined Cover	
4040-31	Cover Screw (2)	F
4040-163	Arm Inserts	F
4040-164	Screw Inserts (2)	F
4040-159	Arm Screw	F

**COVER**

4040-72	Standard Cover	F
	Includes (2) 4040-31, -163 and -164.	
4040-72LL	Lead Lined Cover	F
	Includes (2) 4040-31 -163 and -164.	
4040-72MC	Metal Cover	F,H
	Includes (2) 4040-31.	

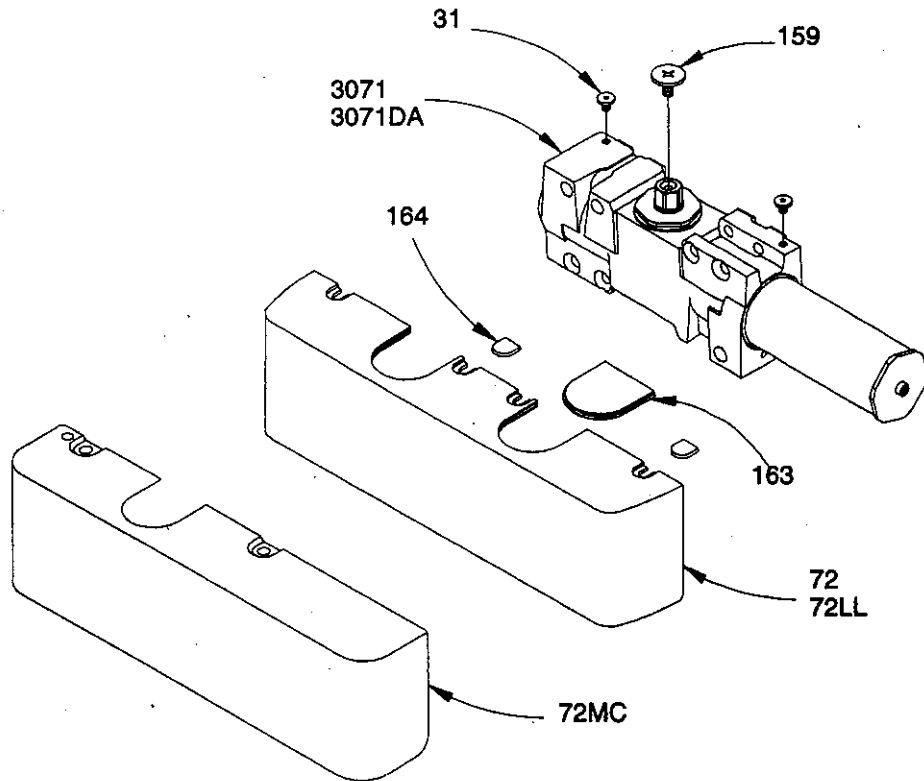

**SUPER SMOOTH™  
SURFACE MOUNTED CLOSER**

Specify finish (F) and hand (H) where indicated.

**COMPLETE ARM**

4040-3077EDA Extra Duty Arm  
Includes 4040-159 and -201.

F

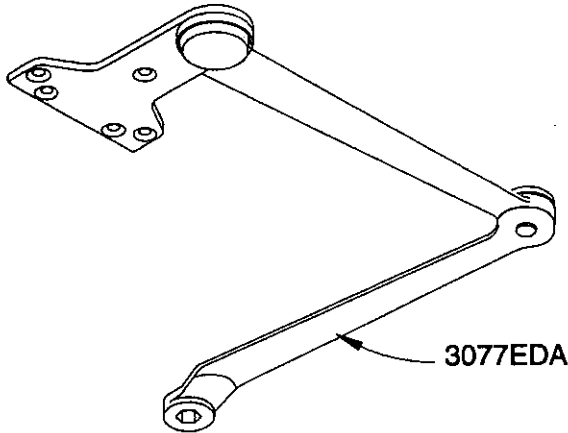

3077EDA

**COMPLETE ARM**

4040-3049EDA Extra Duty Arm  
Includes 4040-159.

F,H

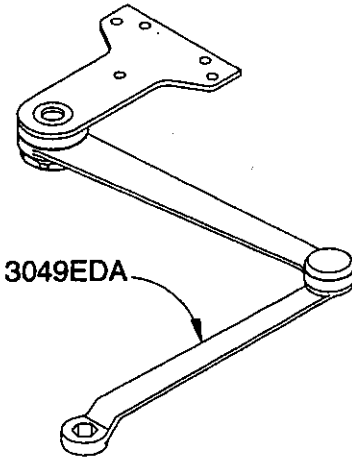

3049EDA

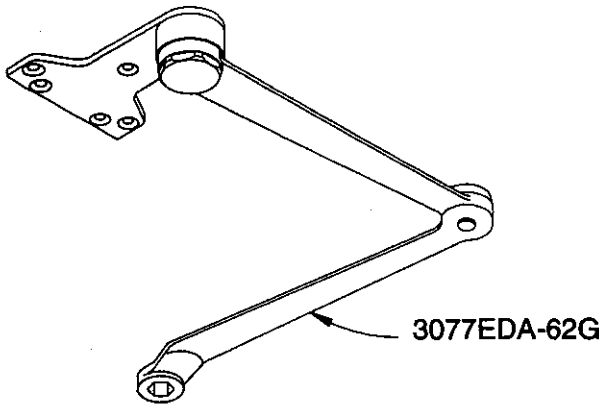

3077EDA-62G

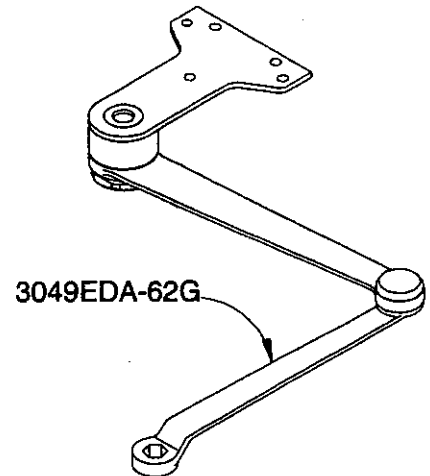

3049EDA-62G

**COMPLETE ARM**

4040-3077EDA-62G Extra Duty Arm  
Includes 4040-159 and -201.

F

**COMPLETE ARM**

4040-3049EDA-62G H Extra Duty Arm  
Includes 4040-159.

F,H

**SUPER SMOOTHEE®  
SURFACE MOUNTED CLOSER**

Specify finish (F) and hand (H) where indicated.

**COMPLETE ARM**

4040-3077CNS Cush-N-Stop Arm  
Includes 4040-159.

F

**COMPLETE ARM**

4040-3049CNS H Cush-N-Stop Arm  
Includes 4040-159.

F

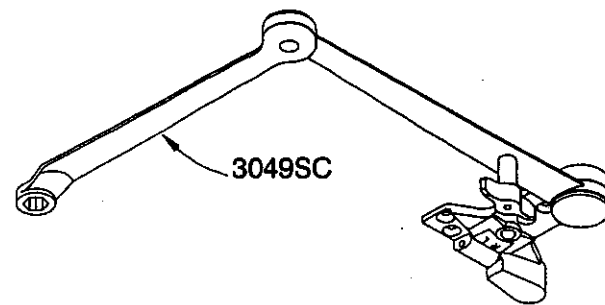
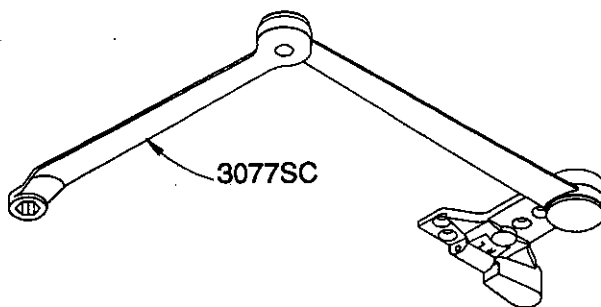
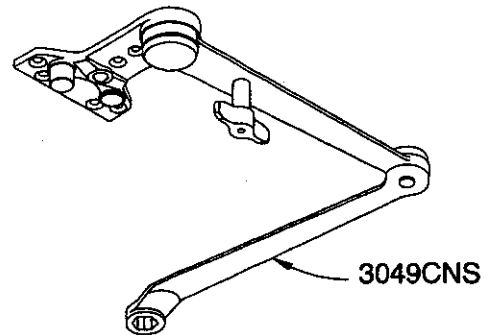
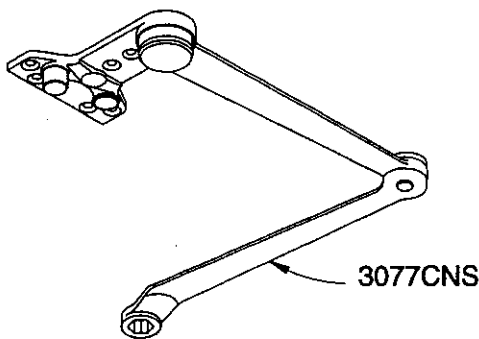

**COMPLETE ARM**

4040-3077SC Spring Cush Arm  
Includes 4040-159.

F

**COMPLETE ARM**

4040-3049SC H Spring Cush Arm  
Includes 4040-159.

F

## HEAVY DUTY 9 SERIES Surface Mount - Interior or Exterior Doors

### Standard Features

- Surface mounted
- Non-handed
- Slide track design
- For use on exterior or interior doors
- Recommended for high traffic, heavy abuse installations
- Heavy shock absorber spring provides 5°-7° compression before dead stop
- On/off knob on hold open models
- Stop, friction stay or hold open function
- Complete screw packet allows for installation in wood or metal door and frame
- For security areas torx screws, optional
- Standard architectural finishes
- Non-metal slide block and shock block
- 110° maximum opening
- 1-3/4" minimum door thickness
- LS option available for doors being used with electromechanical closers and floor closers with dead stop
- Mount on pull side of door use bracket 5458 LH or 5459 RH

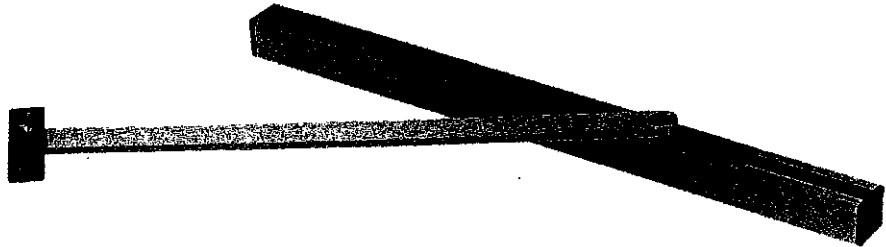
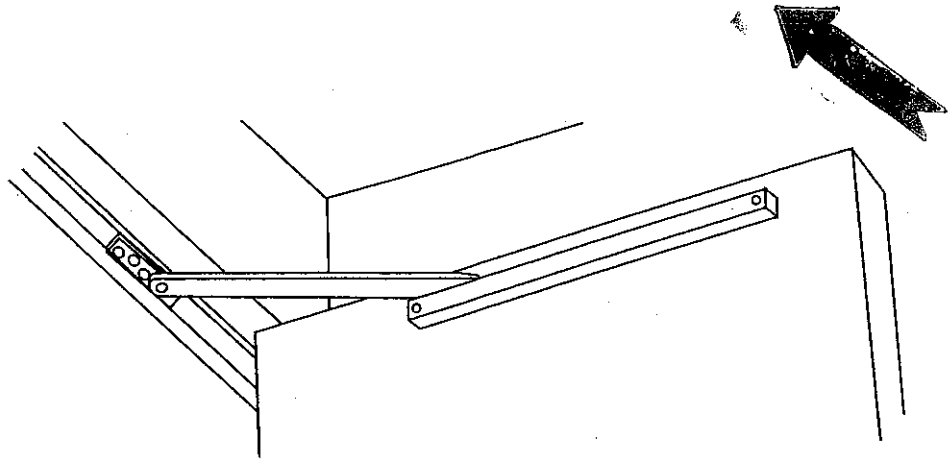

### Door Opening Chart (in inches)

### Model Number

Butts Offset Pivots	Center Hung Pivots	Friction	H.O.	Stop
*24 - 28	25-1/2-30	9-116	9-126	9-136
28-1/16-33	30-1/16-36	9-216	9-226	9-236
33-1/16-38	36-1/16-41	9-316	9-326	9-336
38-1/16-43	41-1/16-46	9-416	9-426	9-436
43-1/16-48	46-1/16-50	9-516	9-526	9-536

\*Butt hung only on this size door.

ANSI No.			
Shipping Weight	Friction	H.O.	Stop
4.5 lbs.	----	C02511	C02541





## Doorplates

Kickplates are an attractive means of protecting a door surface from scuffing due to heavy traffic. A range of heights is available to provide protection from damage by floor cleaning operations, stretchers, industrial carts and trucks. Plates are available in all architectural finishes plus a variety of plastic materials.

### Standard Features:

- All Plates individually packed with screws.
- Stainless Steel 18-8 Phillips head sheet metal screws plated to match.
- Nominal Thickness: Metal Plates - .050", Plastic Plates - .125".
- All Architectural Finishes available up to 48" x 48" except US26D (626) which has a maximum height of 12".
- Westinghouse Micarta® Plastic Laminate is in stock in the following colors: #90M52 Gray, #52M33 Sand, #92M16 Pearl Black, #90M21 Chocolate Brown, #92M90 Cool White. B4E is standard.
- Kydex 160 Heavy Duty PVC/Acrylic Alloy Plastic is stocked in the following colors. #72010 Chocolate Brown, #52001 Pewter Gray, #52000 Calcutta Black, #72005 Beige, #72047 Cocoa.
- Clear Acrylic Plastic. B4E is standard.
- Compliance with BHMA ANSI A156.6 Standards:  
Metal Armorplate = J101  
Metal Kickplate = J102  
Metal Mopplate = J103  
Plastic Armorplate = J105  
Plastic Kickplate = J106  
Plastic Mopplate = J107.

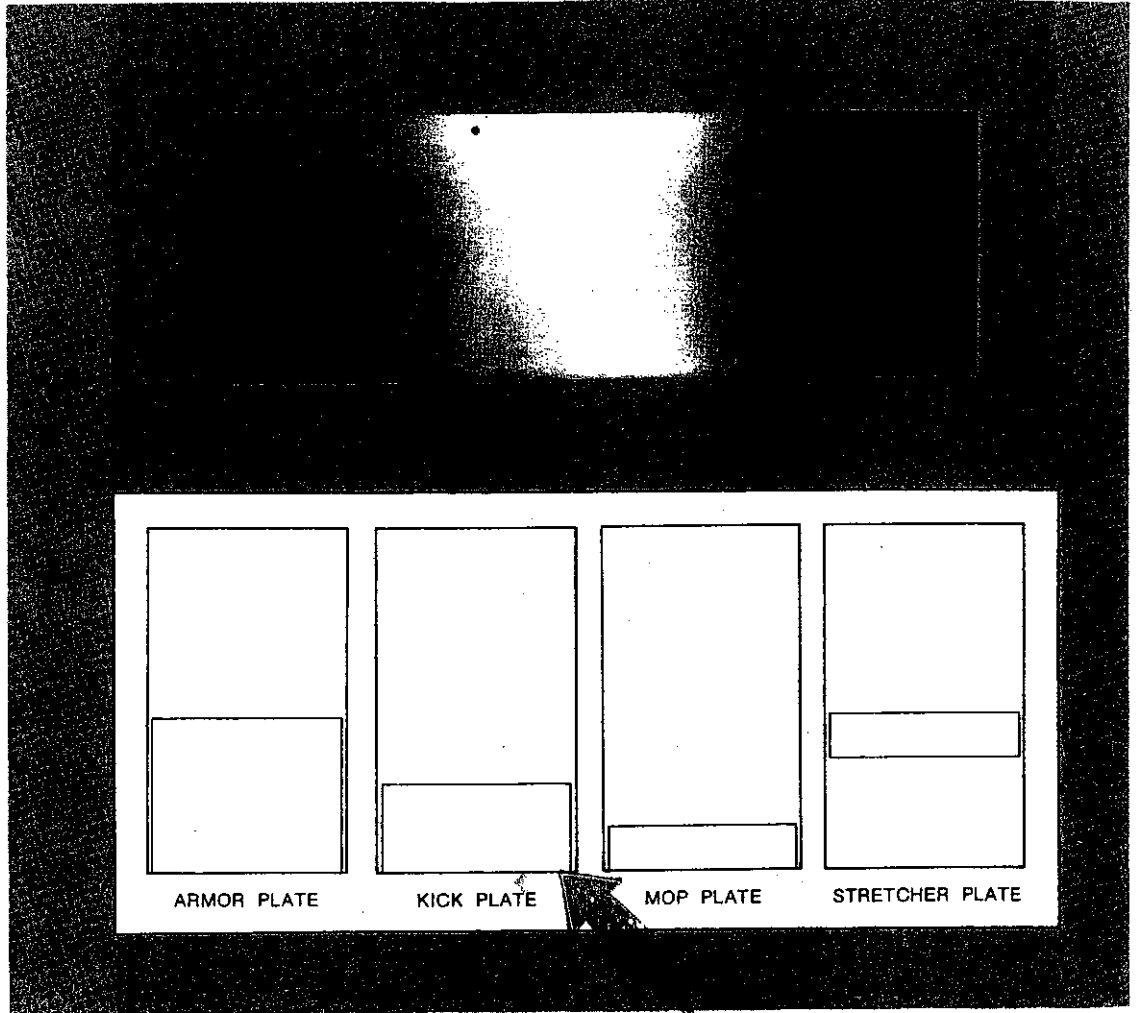

Doorplates are commonly used for protective purposes; for best protection mount plates flush with the bottom of the door. If plates are used primarily for aesthetic reasons (i.e. Brass Kickplates), it may be desirable to mount them up to 1" from the bottom of the door.

### Optional Features:

- Beveled 3 or 4 edges, specify "B3E" or "B4E".
- Machine Screws or Spanner Head Screws.
- Cut outs for Locks, Louvers, or Windows.
- Stainless Steel is available in the following gauges: US20(.038"), US18(.050"), US16(.062"), US11(.125").
- Aluminum, Brass, and Bronze are available in the following gauges: B&S16(.050"), B&S14(.064"), .125", .188".

**Ordering instructions:** Specify Rockwood Kickplate Height x Width x Finish Code x Thickness. Add Any Options such as B3E.

- Weight: Metal 8" x 34" = 4.0 lbs., Plastic 8" x 34" = 1.9 lbs.

# ROCKWOOD

## U. L. Listed Flush and Surface Bolts

#550 and #555 flush bolts are listed for use on A, B, C, D, and E labeled metal doors. Standard rod length is 12". Other lengths are available to order. #554 rabbet piece is designed to fill the mortise gap in rabbeted doors when using our #555. Rabbeted strikes and guides are quoted on request.

#557 flush bolt is U.L. listed for all types of labeled wood fire doors. Door strength is maintained by a reinforcing plate. Simple installation instructions are enclosed in each box. Please specify if door thickness is other than 1 3/4".

#580 and #581 heavy duty surface bolts are U. L. listed for use on the inactive leaf of a pair of labeled fire doors. The bolt is 1/4" thick x 3/4" wide with 1 3/16" throw. It is packed with both top and bottom strike and ms and sms. Sex bolts available, please specify when ordering.

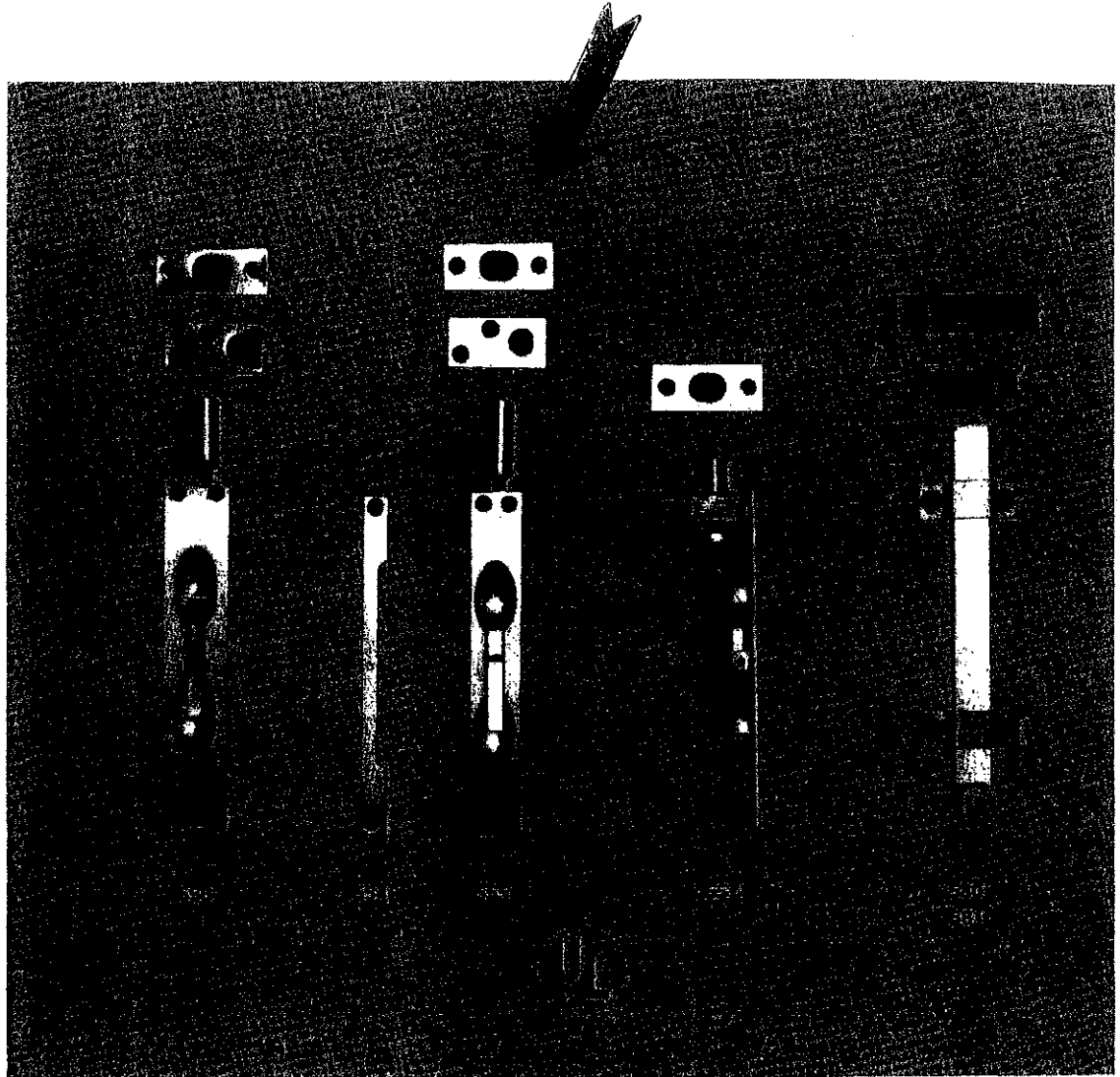

No.	Size	Finishes	Weight	ANSI
550	6 3/4" x 1 1/4"	all architectural	1.7 lbs./2	*****
554	6 3/4" x 1/2"	all architectural	4.1 lbs./10	w/555 L14101
555	6 3/4" x 1"	all architectural	1.5 lbs./2	L14251,L14081
557	6 3/4" x 1"	all architectural	1.7 lbs./2	*****
580	8" bolt	zinc, bronze, chrome, brass	5.3 lbs./5	L84161
581	12" bolt	zinc, bronze, chrome	6.8 lbs./5	*****

# ROCKWOOD

## 1600 Series Coordinators

This non-handed coordinator (with companion filler) is designed to become an integral part of the door frame and when painted with the frame becomes virtually invisible. It is engineered to prevent damage in case of abnormal force against the door that is held open. Stock sizes available for quick shipment are #1660 (60" opening), #1672 (72" opening), and #1696 (96" opening).

Fillers are usually supplied pre-cut from the factory. Note: If "S" dimension is other than 1/2", advise the factory.

The 1600 Series coordinators are manufactured in three different housing lengths to coordinate the full range of door sizes:

- **1600 Series**—for jamb opening widths (A + B dimension) from 54" through 96". E dimension, 52".
- **NX1600 Series**—for jamb opening widths (A + B dimension) from 44" through 76". E dimension, 42".
- **L1600 Series**—for unusual widths and special conditions (minimum jamb opening: 66"). E dimension, 60".

### Determining Coordinator Item Number:

Active door widths A plus inactive door width B equals the last two or three digits of all 1600 Series coordinator item numbers. See examples at bottom right.

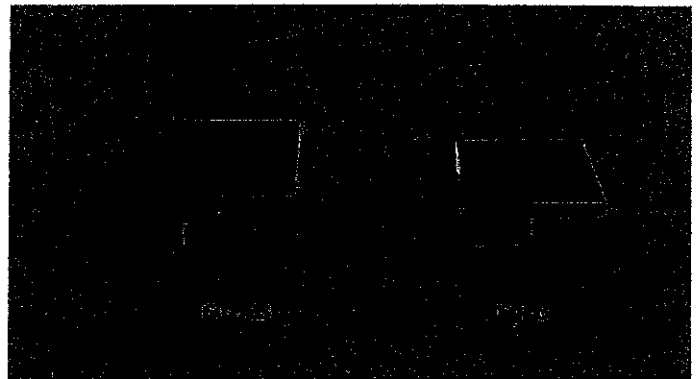
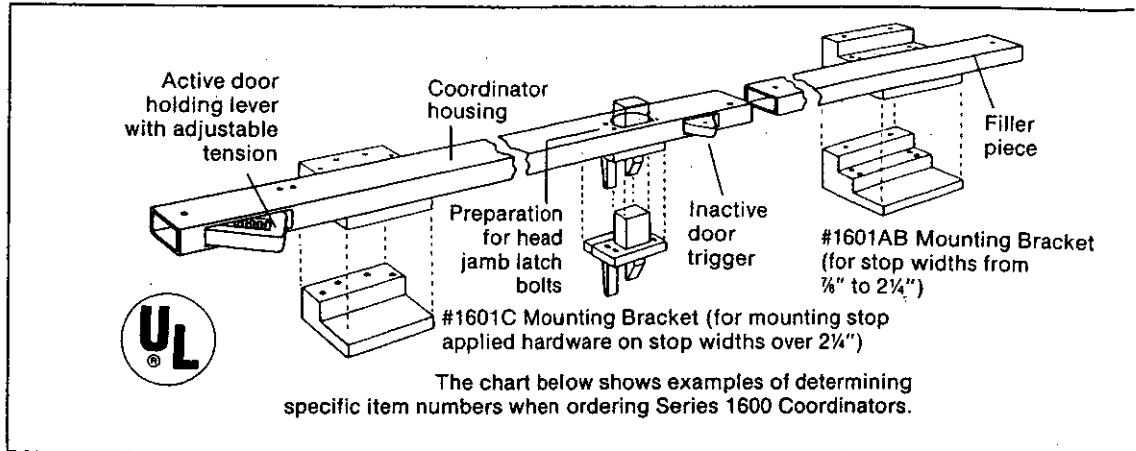

## Carry Bars

#1100 carry bars are recommended for use on all openings with astragals except when the inactive door is equipped with automatic flush bolts. Carry bars are available in standard architectural finishes as well as prime coat steel.

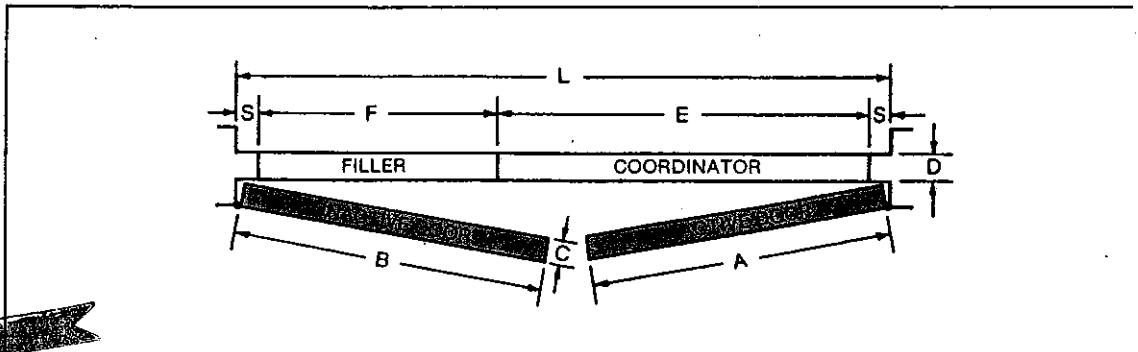

## Mounting Brackets

#1601AB and #1601C mounting brackets are used for stop applied hardware. Their use prevents the inadvertent disabling of the coordinator by fasteners passing through the housing.

Range of Sizes	Series No.	Door Leaf Active (Dim. A)	Widths Inactive (Dim. B)	Sum of Dim. A + B	Item No. Equals Series No. Plus Sum A + B
54" thru 96" (Dim. A + B)	16	36" 42"	36" 18"	72" 60"	1672 1660
44" thru 76" (Dim. A + B)	NX16	24" 36"	24" 12"	48" 48"	NX1648 NX1648
66" (Min. jamb opening) or greater	L16	54" 52"	42" 52"	96" 104"	L1696 L16104

# ROCKWOOD

## 1842/1942 Automatic Flush Bolts

The #1842 is U.L. listed for use on the inactive leaf of a pair of A, B, C, D, and E labeled metal doors. The #1942 is U.L. listed for use on the inactive leaf of a pair of B, C, D, and E labeled wood covered composite doors. The patented non-handed cam triggering device is the heart of this smooth-acting mechanism; only five pounds of force is required to drive a pair of bolts allowing door closing devices to perform at maximum efficiency. An override feature prevents damage to doors or bolts should the bolt heads be prevented from penetrating either the top or bottom strikes. The bolts are adjustable for unusual clearance or conditions and have a thermal lock that automatically locks the inactive door under high heat conditions due to fire. Sold in pairs.

## 1845/1945 Combination Flush Bolts

The combination flush bolt uses one automatic flush bolt for the bottom of the door and a constant self-latching flush bolt for the top of the door. When the active leaf is opened, the bottom automatic flush bolt is opened. However the inactive leaf stays latched at the top until it is manually released by depressing the plunger on the bolt face. The top bolt engages each time the inactive door is closed. The #1845 is U.L. listed for use on A, B, C, D, and E labeled metal doors. The #1945 is U.L. listed for use on B, C, D, and E labeled wood covered composite doors. Sold in sets.

## Dust Proof Strike

#1880 dust proof strike is designed specifically for use with our automatic flush bolts. Use it wherever dirt clogging a strike hole is a problem.

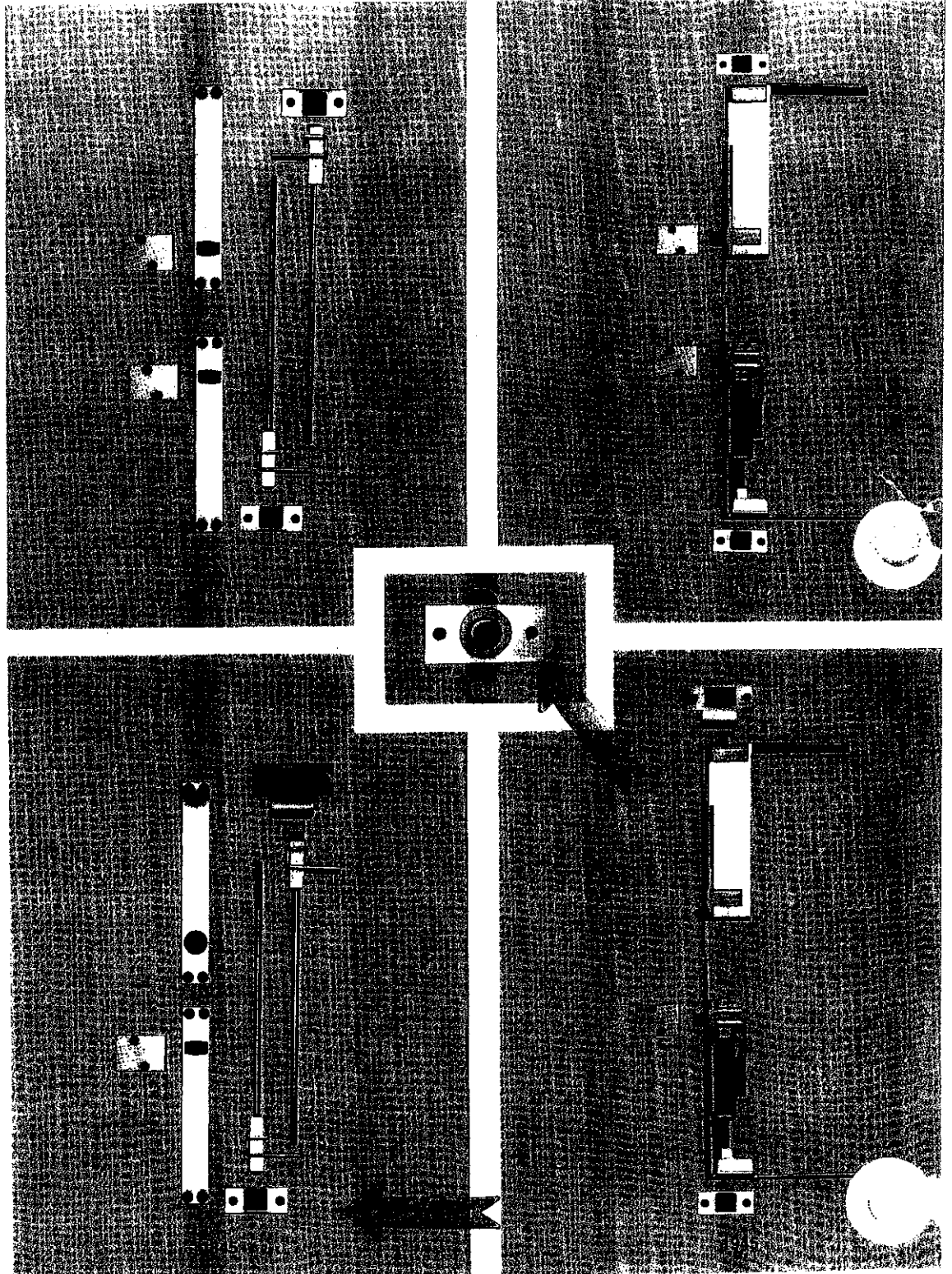

# ROCKWOOD

## Gate Latch, Door Guard & Silencers

Our #600 and #602 secret gate latch is single acting, reversible and supplied with a dummy knob.

Our #603 and #604 security door guards are easier to use than a chain door guard and eliminates the marring of the door frame caused by chain door guards.

The #605 edge guard is designed to protect the door or frame from marring when used in conjunction with a #603 or 604 door guard.

The #608 and #609 are rubber door silencers for metal and wood frames respectively.

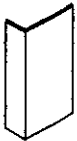

605



608



609

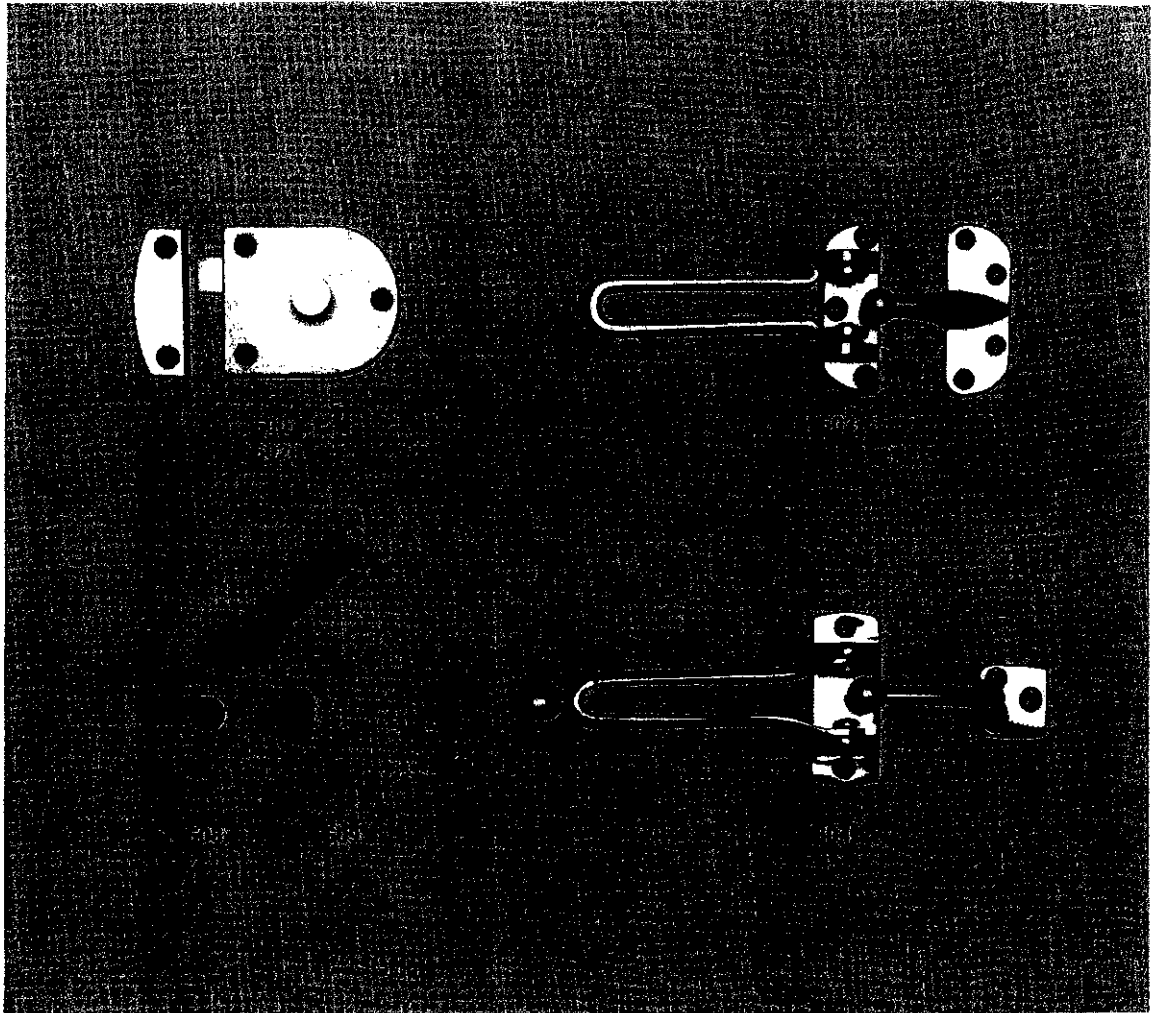

No.	Material	Size	Finishes	Weight	ANSI
600	Aluminum	Case: 2" x 2 3/4"	Sprayed Aluminum	1.5 lbs./6	*****
		Strike: 2" x 2 3/4"	Brass, Bronze, Black		
602	Brass	Case: 2" x 2 3/4"	Dull Brass, Bronze	3.4 lbs./6	*****
		Strike: 2" x 2 3/4"	Dull Chrome		
603	Aluminum	Jamb Plate: 29/32" x 2 1/2"	Dull Chrome	4.2 lbs./10	L33042
		Strike Plate: 31/32" x 2 1/2"	Polished Brass, Antique Brass		
604	Brass	Jamb Plate: 1 1/16" x 29/16"	Polished Brass	4.4 lbs./10	L13042
		Strike Plate: 1 1/16" x 1 1/16"	Dull Chrome		
605	Brass	1 1/8" x 1" x 1/2" return	same as above	0.3 lbs./10	*****
608	Gray Rubber	1/2" diameter x 5/8"		1.3 lbs./500	L03011
609	Gray Rubber	3/8" x 3/4"		1.3 lbs./500	L03021

# ROCKWOOD

## Wall Bumpers

#400 - #405 feature a solid forged brass housing with a concealed in the bumper attachment. The backplate fully distributes the impact of the door to prevent damage to the wall.

#406 - #411 are wrought preassembled wall bumpers with concealed-in-the-bumper fastening. All of these Rockwood wall bumpers feature a non-yellowing low durometer rubber bumper that softly cushions the door knob. And the metal backplate is designed to distribute the impact of door contact to protect the wall surface.

See page F7 for Poly Pack box quantities.

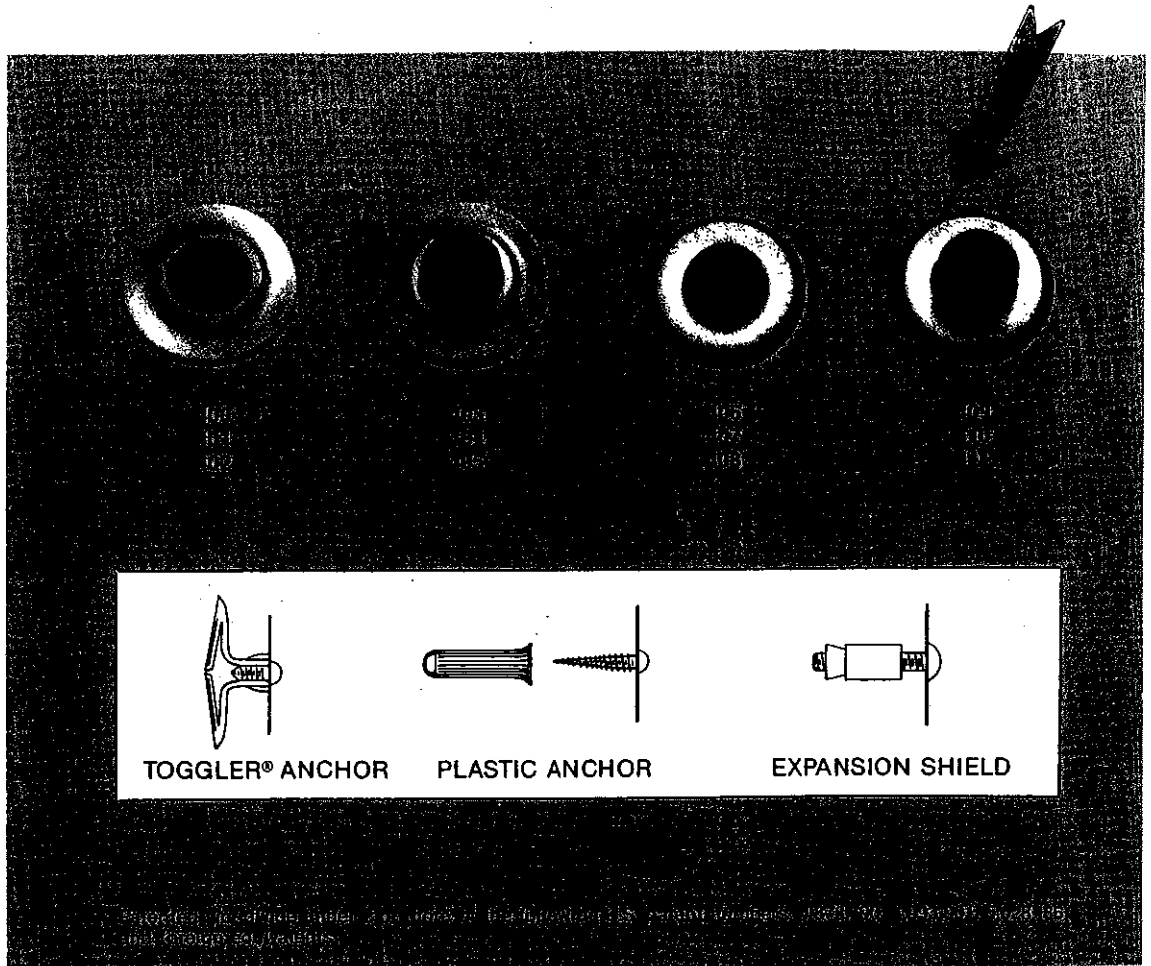

No.	Bumper	Fastener	Size	Weight	ANSI
400	convex	sms and Togglor®	2 1/8" diameter	3.3 lbs./10	L12101
401	convex	ws and anchor	3/4" projection	3.3 lbs./10	L12101
402	convex	ms and exp. shield		3.3 lbs./10	L12101
403	concave	sms and Togglor®		3.3 lbs./10	L12251
404	concave	ws and anchor		3.3 lbs./10	L12251
405	concave	ms and exp. shield		3.3 lbs./10	L12251
406	convex	sms and Togglor®	2 1/8" diameter	1.8 lbs./10	L22101, L52101
407	convex	ws and anchor	3/4" projection	1.8 lbs./10	L22101, L52101
408	convex	ms and exp. shield		1.8 lbs./10	L22101, L52101
409	concave	sms and Togglor®		1.8 lbs./10	L22251, L52251
410	concave	ws and anchor		1.8 lbs./10	L22251, L52251
411	concave	ms and exp. shield		1.8 lbs./10	L22251, L52251

## Push Plates

Push plates are available in all architectural finishes, clear plastic and Westinghouse Micarta® laminate plastic. The most popular variations and sizes are shown on this page, but any size may be obtained by special order. Push plates are supplied with phillips oval head stainless steel sheet metal screws, plated to match. #70, #71 and #75 have four beveled edges; #73 and #74 have square edges on the sides and rounded edges on top and bottom, with four beveled edges available as a no cost option.

**Standard sizes:**

- A = 3" x 12"
- B = 3½" x 15"
- C = 4" x 16"
- E = 6" x 16"
- F = 8" x 16"

To order, specify plate number followed by size designation and finish, i.e. 70B US32D or for non-standard size 70 (width x height) and finish.

**OPTIONAL FEATURES:**

**Adhesive mounting.** Specify push plate number "x scotch mount." The push plate will have a 1/16" thick double face foam tape applied to the back side and will have no screw holes.

**Engraving.** On plates 4" wide or wider it is possible to engrave "PUSH", "PULL", "MEN" or "WOMEN". Please indicate the copy you require and see page A12 for standard engraving location.

**Cylinder and turn knob cutouts.** Specify the push plate number "x C/C" for cut for cylinder and "x C/TK" for cut for turn knob. See page A12 for standard locations and sizes.

**Rounded corners.** Specify plate number "x RC".

**Two rounded corners.** Specify plate number "x 2RC".

**Rounded ends.** Specify plate number "x RE".

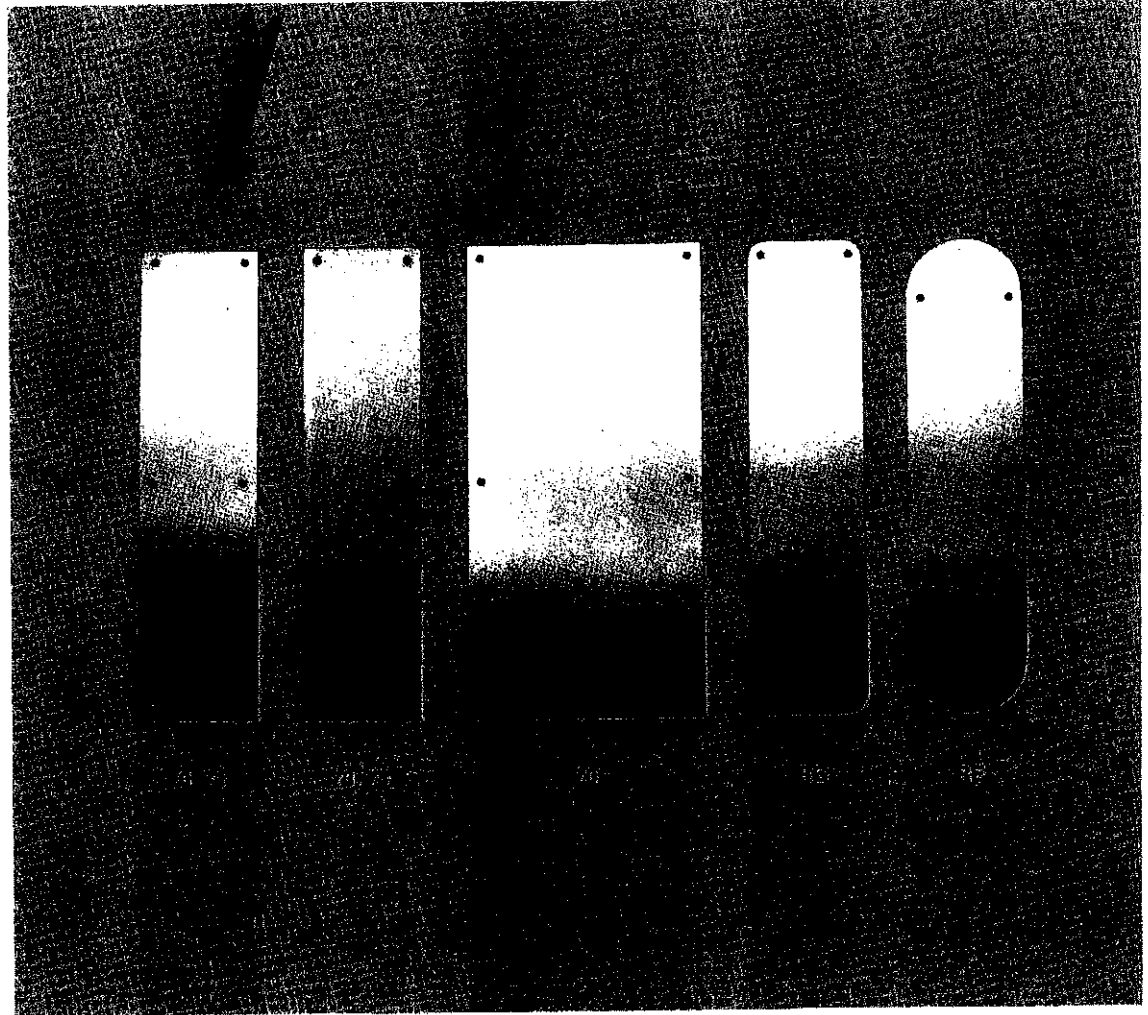

No.	Material	Weight*	ANSI	Suffix For End Modifications
70	.050 wrought	1.0 lbs.	J301	RC = rounded corners
71	.062 wrought	1.2 lbs.	J301	2RC = 2 rounded corners (not shown)
73	.125 wrought	2.2 lbs.	J304	RE = rounded ends
74	.188 wrought	3.8 lbs.	J304	
75	.125 plastic	.5 lbs.	J304	

\*For 4" x 16"

# BF SERIES DOOR PULLS

This selection of door pulls provides the 2 1/2" clearance we recommend for the upper limb impaired. Push plates are available for door protection as well as for indicating which side of the door to push on.

## RECOMMENDED LOCATIONS ON DOOR:

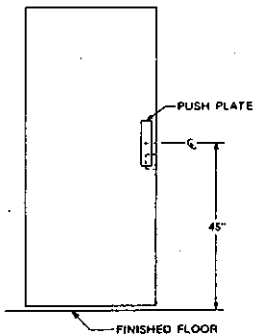
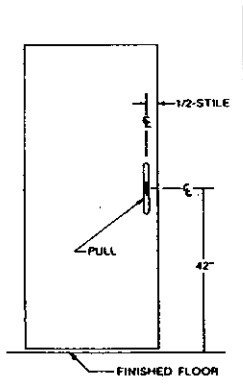

See standards quoted  
on back 4.13.9

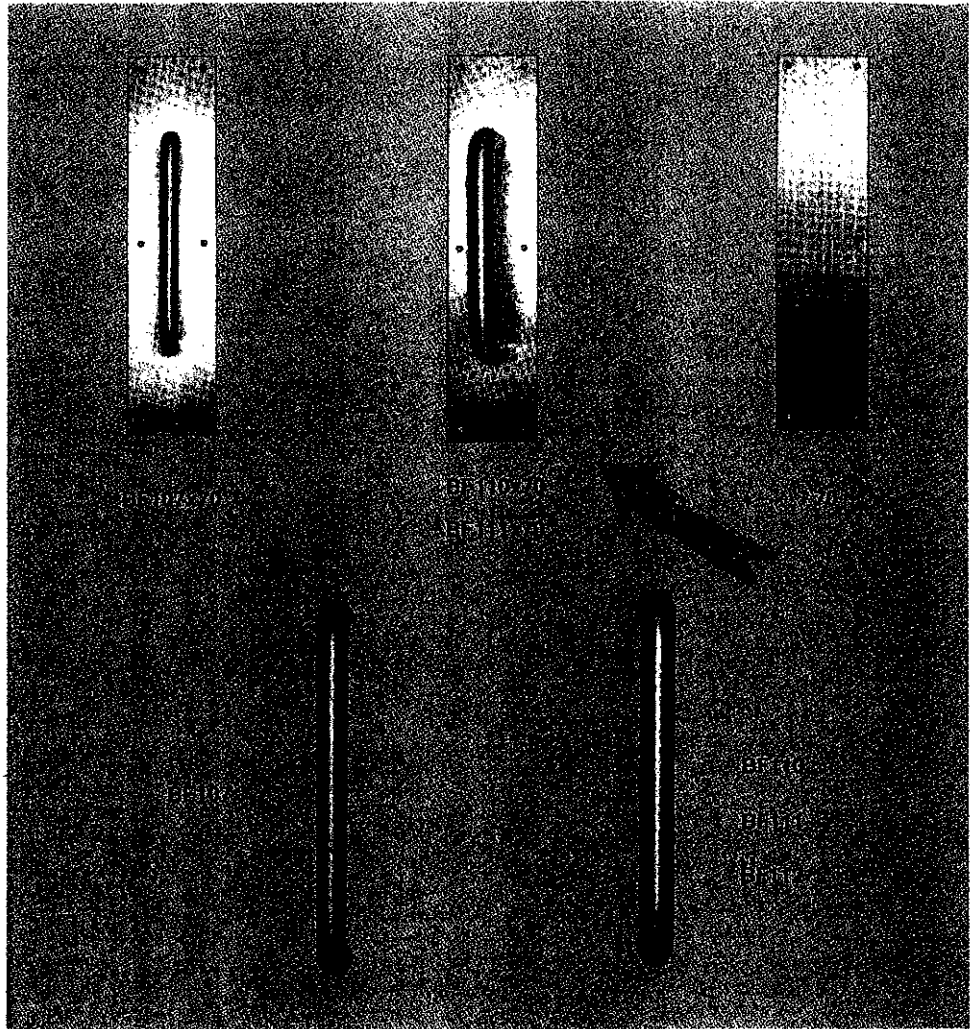

No.	Material	CTC	Overall	Projection	Clearance	Base
BF107	3/4" diameter	8"	8 3/4"	3 1/4"	2 1/2"	3/4"
BF110	1" diameter	8"	9"	3 1/2"	2 1/2"	1"
BF111	1" diameter	10"	11"	3 1/2"	2 1/2"	1"
BF112	1" diameter	12"	13"	3 1/2"	2 1/2"	1"

# BF690 SERIES TACTILE SIGNAGE

BF690M    BF690W    BF690R  
10 1/2" high    12" high    12" high

Economical molded plastic sign is adhesive mounted in blue with raised letters and braille translation. Offers complete compliance in an inexpensive sign.

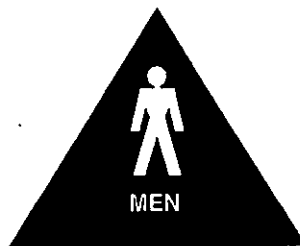

BF690M



BF690W



BF690R



1-800-328-0953

# Sill Protection

WEATHERSTRIPS & THRESHOLDS

M15A  
M15C  
M15D  
M15G

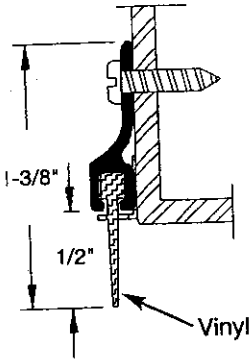

M35A  
M35C  
M35D  
M35G

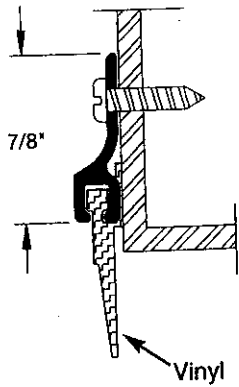

323A  
323B  
323C  
323D  
323G

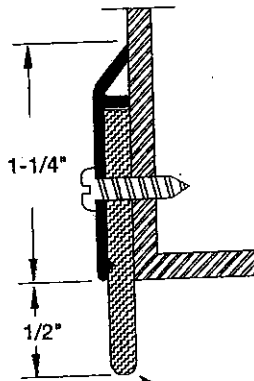

362A  
362B  
362C  
362D  
362G

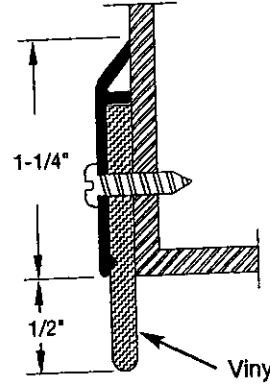

377C  
377D  
377G

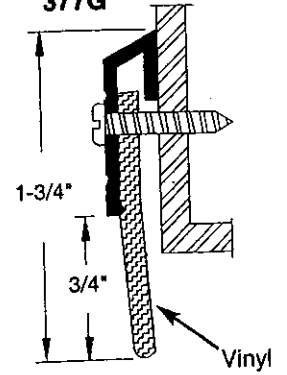

DB469C  
DB469D  
DB469G

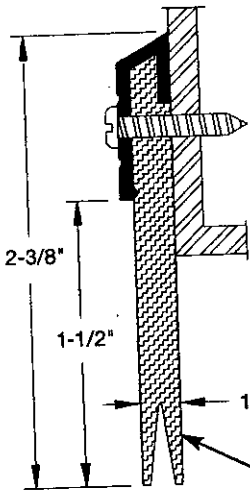

602C  
602D  
602G

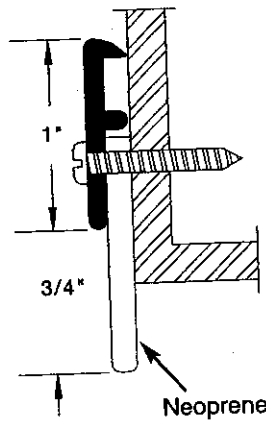

603C  
603D  
603G

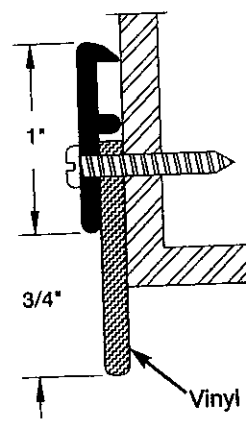

772A  
772B  
772C  
772D  
772G

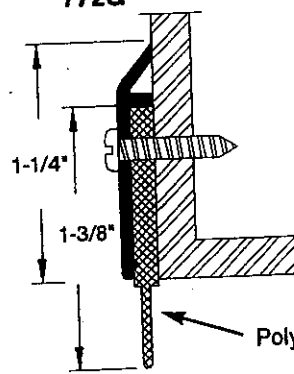

773A  
773C  
773D  
773G

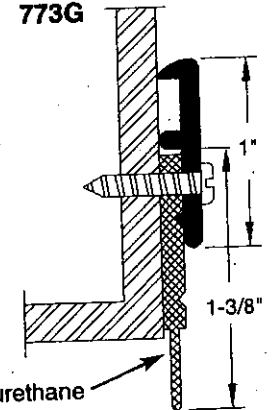

805A  
805C  
805D  
805G

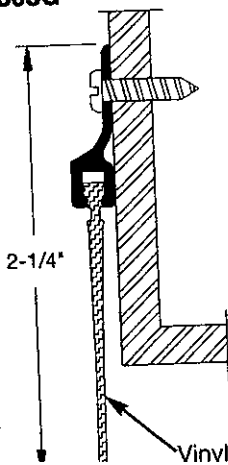

806A  
806C  
806D  
806G

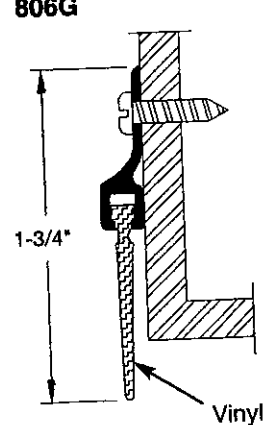

810C  
810D  
810G

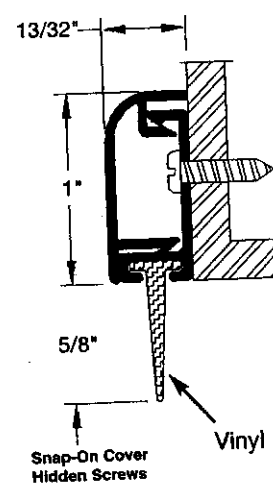

825A  
825C  
825D  
825G

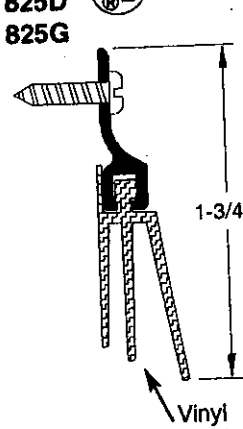

967C  
967D

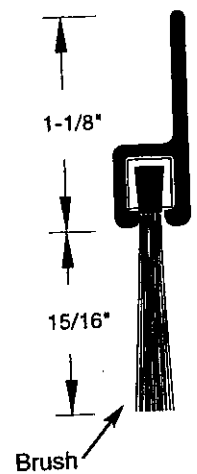

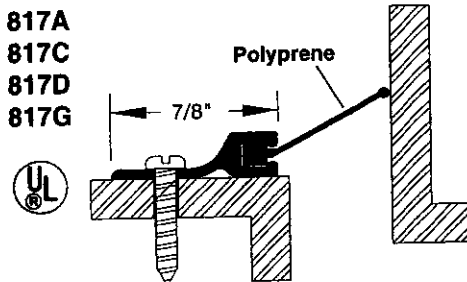
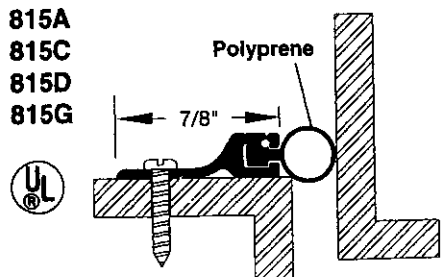
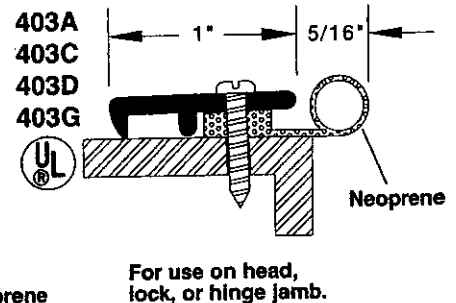
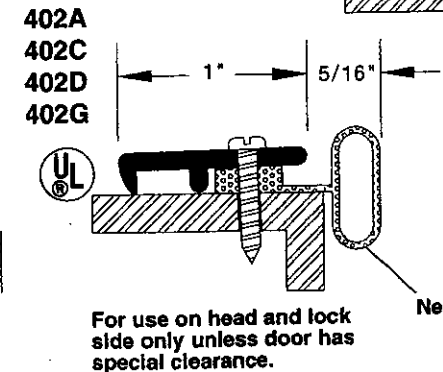
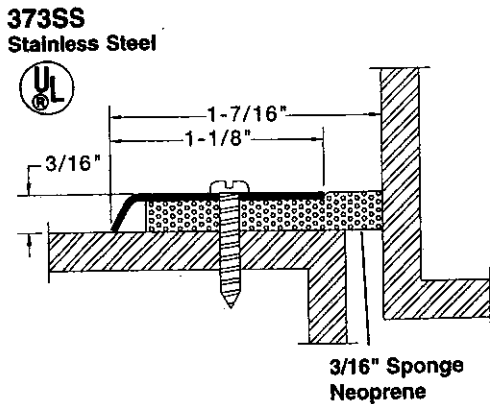
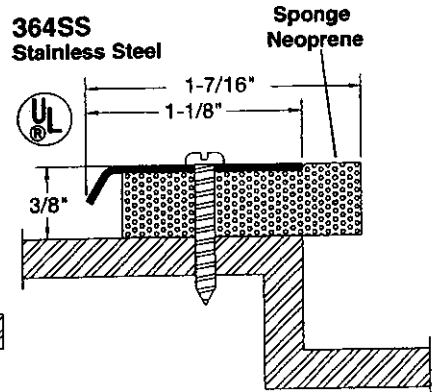
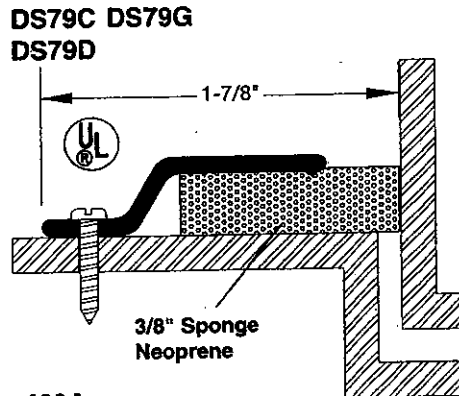
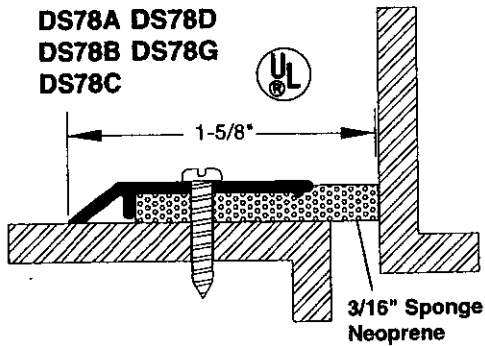
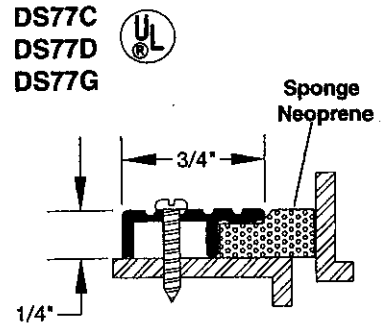
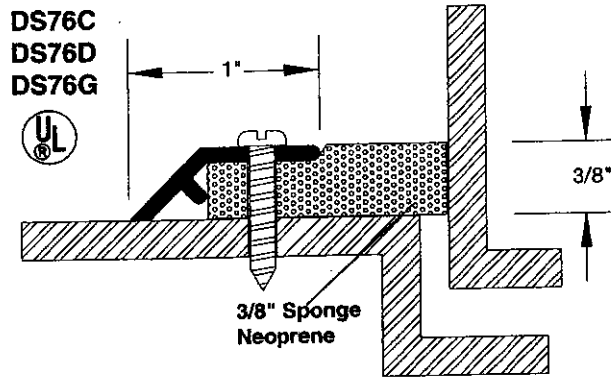
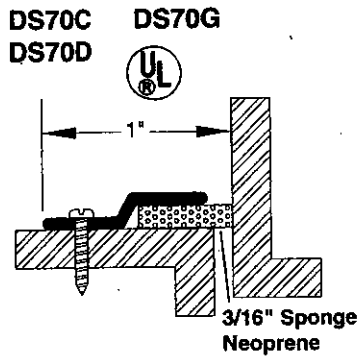
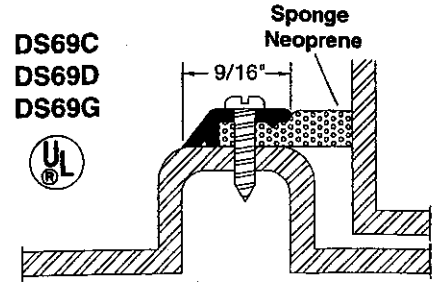
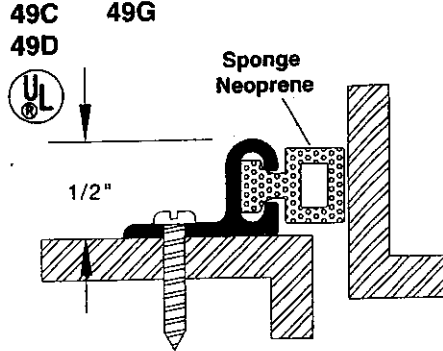
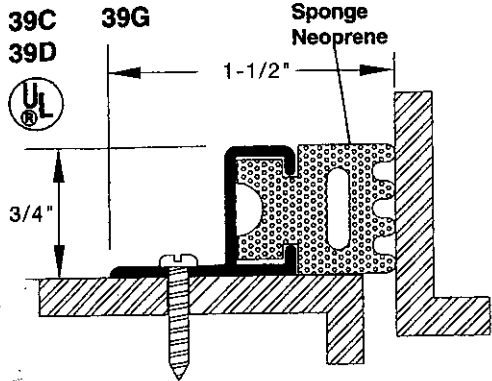

**Finish Designations:**

A	Aluminum mill finish
B	Architectural bronze (brass)
C	Clear anodized aluminum
D	Dark bronze anodized aluminum
G	Gold anodized aluminum

# Saddle Thresholds

S225A

S225B

S225D

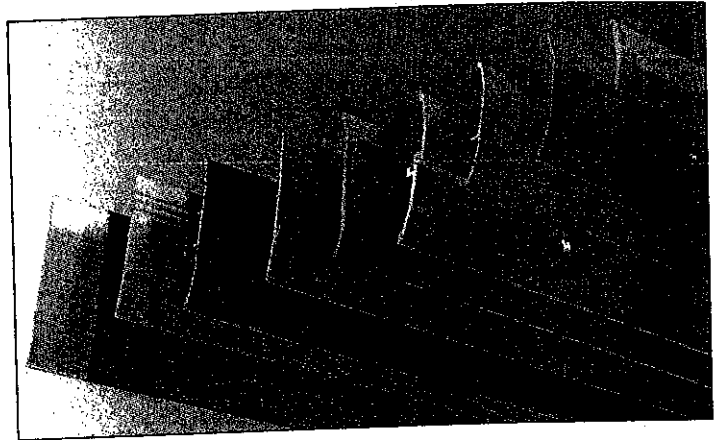
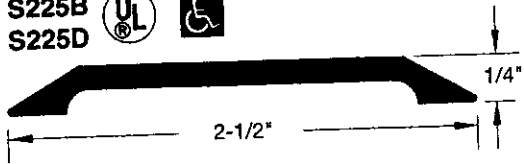

S263A

S263B

S263D

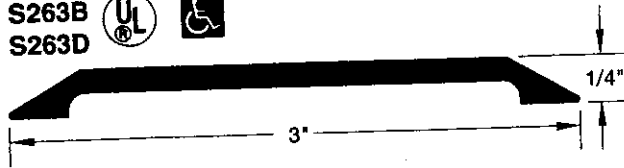

S404A

S404B

S404D

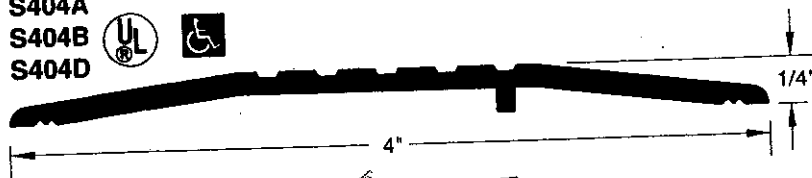

S405A

S405D

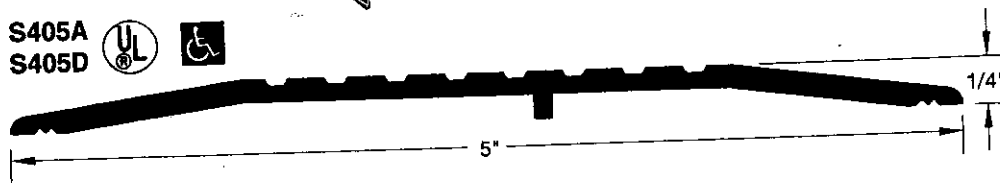

S803A

S803D

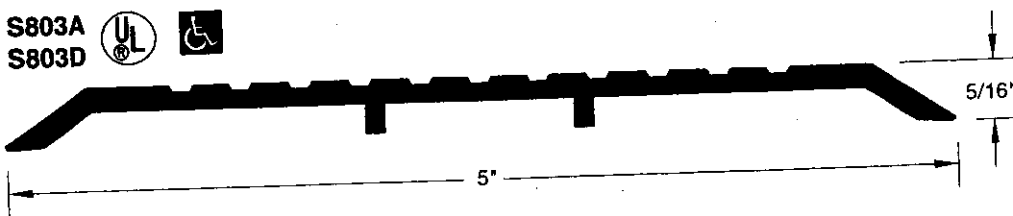

S406A

S406D

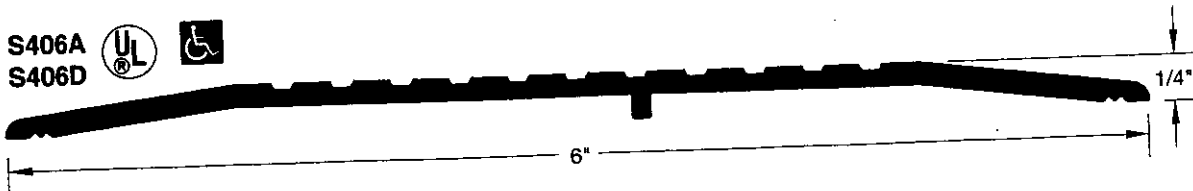

S407A

S407B

S407D

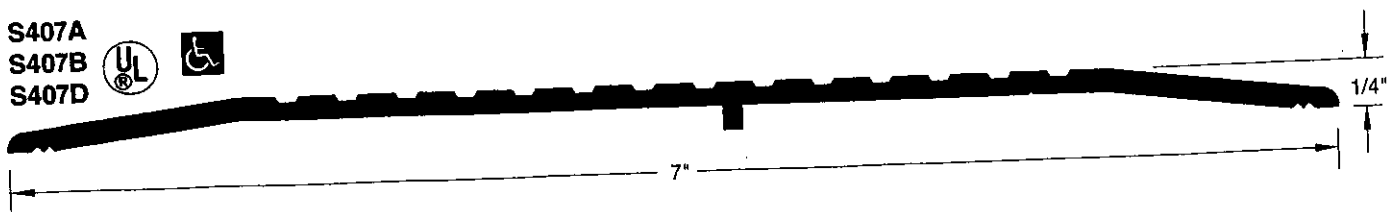

**Finish Designations:**

- A Aluminum mill finish
- B Architectural bronze (brass)
- D Dark bronze anodized aluminum
- PG Perfect Grit abrasive

S483A S483B S483D

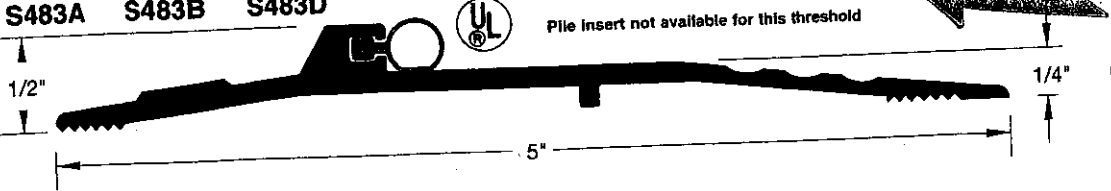

INSERT OPTIONS FOR S483 AND S257

- U — polyurethane
- V — vinyl
- PR — polyprene

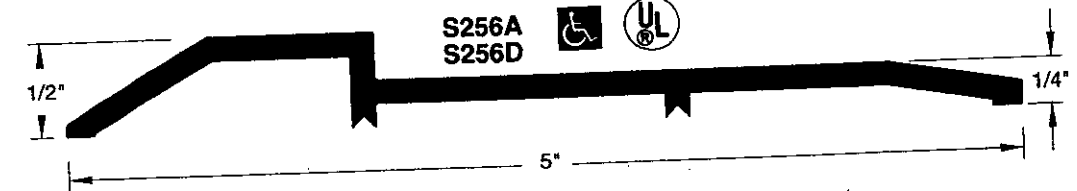
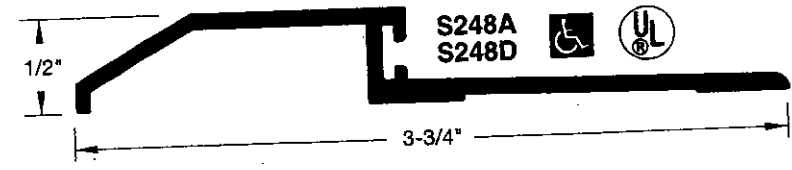
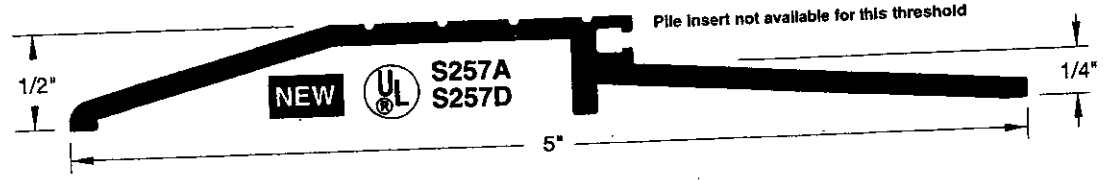

**Finish Designations:**

- A Aluminum mill finish
- B Architectural bronze (brass)
- D Dark bronze anodized aluminum
- PG Perfect Grit abrasive

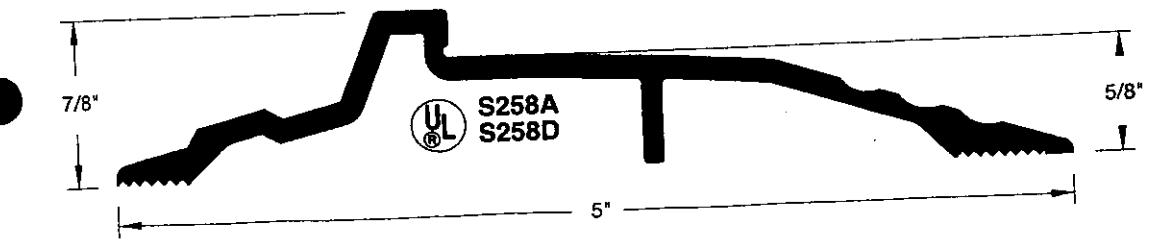
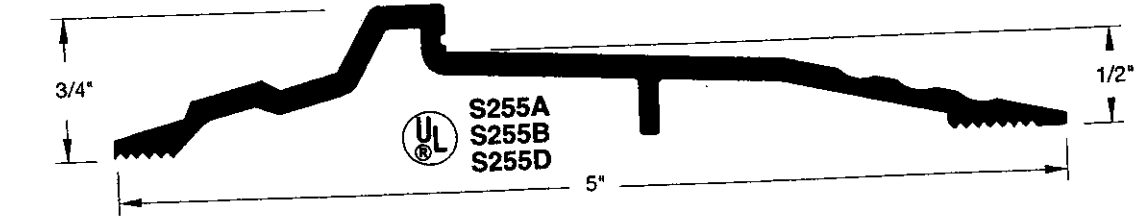
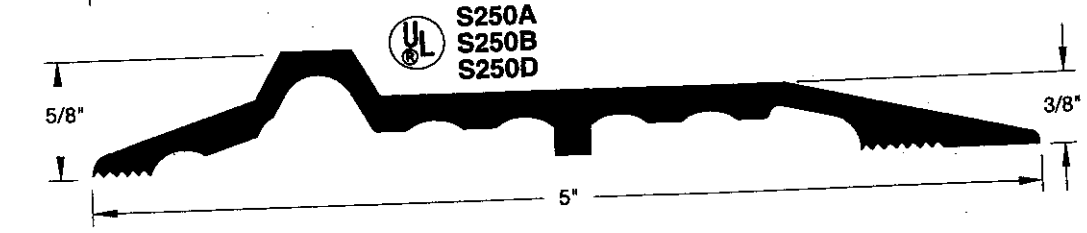
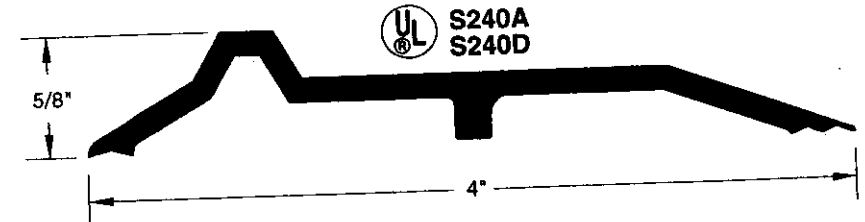

**SECTION 100040  
ACCESS DOORS AND FRAMES**

**PART 1 - GENERAL**

**1.1 SUMMARY**

- A. Section Includes:
  - 1. Access doors and frames for walls and ceilings.

**1.2 ACTION SUBMITTALS**

- A. Product Data: For each type of product.
  - 1. Include construction details, fire ratings, materials, individual components and profiles, and finishes.
- B. Shop Drawings:
  - 1. Include plans, elevations, sections, details, and attachments to other work.
  - 2. Detail fabrication and installation of access doors and frames for each type of substrate.
- C. Samples: For each door face material, at least 3 by 5 inches in size, in specified finish.
- D. Product Schedule: Provide complete access door and frame schedule, including types, locations, sizes, latching or locking provisions, and other data pertinent to installation.

**PART 2 - PRODUCTS**

**2.1 PERFORMANCE REQUIREMENTS**

- A. Fire-Rated Access Doors and Frames: Units complying with NFPA 80 that are identical to access door and frame assemblies tested for fire-test-response characteristics according to the following test method and that are listed and labeled by UL or another testing and inspecting agency acceptable to authorities having jurisdiction:
  - 1. NFPA 252 or UL 10B for fire-rated access door assemblies installed vertically.
  - 2. NFPA 288 for fire-rated access door assemblies installed horizontally.

**2.2 ACCESS DOORS AND FRAMES FOR WALLS AND CEILINGS**

- A. Manufacturers: Subject to compliance with requirements, available manufacturers offering products that may be incorporated into the Work include, but are not limited to, the following:
  - 1. Access Panel Solutions.

2. Acudor Products, Inc.
3. Alfab, Inc.
4. Babcock-Davis.
5. Cendrex Inc.
6. Elmdor/Stoneman Manufacturing Co.; Div. of Acorn Engineering Co.
7. Jensen Industries; Div. of Broan-Nutone, LLC.
8. J. L. Industries, Inc.; Div. of Activar Construction Products Group.
9. Karp Associates, Inc.
10. Larsen's Manufacturing Company.
11. Maxam Metal Products Limited.
12. Metropolitan Door Industries Corp.
13. MIFAB, Inc.
14. Milcor Inc.
15. Nystrom, Inc.
16. Williams Bros. Corporation of America (The).

B. Source Limitations: Obtain each type of access door and frame from single source from single manufacturer.

C. Flush Access Doors with Concealed Flanges:

1. Assembly Description: Fabricate door to fit flush to frame. Provide frame with concealed flange installation.
2. Locations: Wall and ceiling.
3. Door Size: Refer to Mechanical Drawings or as required for each access application.
4. Uncoated Steel Sheet for Door: Nominal 0.060 inch, 16 gage.
  - a. Finish: Factory finish. Color to match adjacent finish color.
5. Frame Material: Same material and thickness as door.
6. Hinges: Manufacturer's standard.
7. Hardware: Lock.

D. Fire-Rated, Flush Access Doors with Concealed Flanges:

1. Assembly Description: Fabricate door to fit flush to frame, with a core of mineral-fiber insulation enclosed in sheet metal. Provide self-latching door with automatic closer and interior latch release. Provide frame with concealed flange installation.
2. Locations: Wall.
3. Fire-Resistance Rating: Not less than that of adjacent construction.
4. Temperature-Rise Rating: 450 deg F at the end of 30 minutes.
5. Uncoated Steel Sheet for Door: Nominal 0.036 inch, 20 gage.
  - a. Finish: Factory finish. Color to match adjacent finish color.
6. Frame Material: Same material, thickness, and finish as door.
7. Hinges: Manufacturer's standard.
8. Hardware: Lock.

E. Hardware:

1. Lock: Cylinder.

## 2.3 MATERIALS

- A. Steel Plates, Shapes, and Bars: ASTM A 36.
- B. Steel Sheet: Uncoated or electrolytic zinc coated, ASTM A 879, with cold-rolled steel sheet substrate complying with ASTM A 1008, Commercial Steel (CS), exposed.
- C. Frame Anchors: Same type as door face.
- D. Inserts, Bolts, and Anchor Fasteners: Hot-dip galvanized steel according to ASTM A 153 or ASTM F 2329.

## 2.4 FABRICATION

- A. General: Provide access door and frame assemblies manufactured as integral units ready for installation.
- B. Metal Surfaces: For metal surfaces exposed to view in the completed Work, provide materials with smooth, flat surfaces without blemishes. Do not use materials with exposed pitting, seam marks, roller marks, rolled trade names, or roughness.
- C. Doors and Frames: Grind exposed welds smooth and flush with adjacent surfaces. Furnish attachment devices and fasteners of type required to secure access doors to types of supports indicated.
  1. Provide mounting holes in frames for attachment of units to metal framing.
  2. Provide mounting holes in frame for attachment of masonry anchors.
- D. Latching Mechanisms: Furnish number required to hold doors in flush, smooth plane when closed.
  1. For cylinder locks, furnish two keys per lock and key all locks alike.

## 2.5 FINISHES

- A. Comply with NAAMM's "Metal Finishes Manual for Architectural and Metal Products" for recommendations for applying and designating finishes.
- B. Protect mechanical finishes on exposed surfaces from damage by applying a strippable, temporary protective covering before shipping.
- C. Appearance of Finished Work: Noticeable variations in same piece are not acceptable. Variations in appearance of adjoining components are acceptable if they are within the range of approved Samples and are assembled or installed to minimize contrast.
- D. Steel Finishes:

1. Factory Prime: Apply manufacturer's standard, fast-curing, lead- and chromate-free, universal primer immediately after surface preparation and pretreatment.
2. Factory Finish: Immediately after cleaning and pretreating, apply manufacturer's standard two-coat, baked-on finish consisting of prime coat and thermosetting topcoat, with a minimum dry-film thickness of 1 mil for topcoat.

## PART 3 - EXECUTION

### 3.1 EXAMINATION

- A. Examine substrates for compliance with requirements for installation tolerances and other conditions affecting performance of the Work.
- B. Proceed with installation only after unsatisfactory conditions have been corrected.

### 3.2 INSTALLATION

- A. Comply with manufacturer's written instructions for installing access doors and frames.
- B. Install doors flush with adjacent finish surfaces or recessed to receive finish material.

### 3.3 ADJUSTING

- A. Adjust doors and hardware, after installation, for proper operation.
- B. Remove and replace doors and frames that are warped, bowed, or otherwise damaged.

\*\* END OF SECTION \*\*



**SECTION 10050**  
**WINDOW LIGHT KITS**

PART 1 - GENERAL

1.1 WINDOW LIGHT KITS

- A. Light kits are required in all occupied office spaces and should be equipped with School Guard Glass.

**\*\* END OF SECTION \*\***

## **SECTION 100060**

### **SECTIONAL DOORS**

#### **PART 1 - GENERAL**

##### **1.1 SUMMARY**

###### **A. Section includes:**

1. Insulated Sectional Overhead Doors.
2. Electric Operators and Controls.
3. Operating Hardware, tracks, and support.

###### **B. Related Requirements:**

1. Section 24 - Cast-In-Place Concrete: Prepared opening in concrete. Execution requirements for placement of anchors in concrete wall construction.
2. Section 24 – Unit Masonry Assemblies: Prepared opening in masonry. Execution requirements for placement of anchors in masonry wall construction.
3. Section 24 – Joint Sealants: Perimeter sealant and backup materials.
4. Section 10 – Door Hardware: Cylinder locks.
5. Section 24 – High Performance Coatings: Field painting.
6. Section 18 – Raceway and Boxes: Empty conduit from control station to door operator.
7. Section 18 – Wiring Connections: Electrical service to door operator.

##### **1.2 REFERENCES**

- A. ANSI/DASMA 102 - American National Standard Specifications for Sectional Overhead Type Doors.

##### **1.3 DESIGN/PERFORMANCE REQUIREMENTS**

- A. Wind Loads: Design and size components to withstand loads caused by pressure and suction of wind acting normal to plane of wall as calculated in accordance with applicable code.
  1. Design pressure of 27 lb/sq ft acting inward and outward.
- B. Wiring Connections: Requirements for electrical characteristics.
  1. 115 volts, single phase, 60 Hz.
- C. Single-Source Responsibility: Provide doors, tracks, motors, and accessories from one manufacturer for each type of door. Provide secondary components from source acceptable to manufacturer of primary components.

#### 1.4 ACTION SUBMITTALS

- A. Product Data: Manufacturer's data sheets on each product to be used, including:
  - 1. Preparation instructions and recommendations.
  - 2. Storage and handling requirements and recommendations.
  - 3. Installation methods.
- B. Shop Drawings: Indicate plans and elevations including opening dimensions and required tolerances, connection details, anchorage spacing, hardware locations, and installation details.
- C. Manufacturer's Certificates: Certify products meet or exceed specified requirements.
- D. Operation and Maintenance Data.

#### 1.5 QUALITY ASSURANCE

- A. Manufacturer Qualifications: Company specializing in manufacturing products specified in this section with minimum five years documented experience.
- B. Installer Qualifications: Authorized representative of the manufacturer with minimum five years documented experience.
- C. Products Requiring Electrical Connection: Listed and classified by Underwriters Laboratories, Inc. acceptable to authority having jurisdiction as suitable for purpose specified.

#### 1.6 DELIVERY, STORAGE, AND HANDLING

- A. Store products in manufacturer's unopened labeled packaging until ready for installation.
- B. Protect materials from exposure to moisture until ready for installation.
- C. Store materials in a dry, ventilated weathertight location.

#### 1.7 PROJECT CONDITIONS

- A. Pre-Installation Conference: Convene a pre-installation conference just prior to commencement of field operations, to establish procedures to maintain optimum working conditions and to coordinate this work with related and adjacent work.

#### 1.8 WARRANTY

- A. Warranty: Manufacturer's limited door and operators System warranty for 10 year against delamination of polyurethane foam from steel face and all other components for 3 years or 20,000 cycles, whichever comes first.

## PART 2 - PRODUCTS

### 2.1 MANUFACTURERS

- A. Acceptable Manufacturer: Overhead Door Corp., 2501 S. State Hwy. 121, Suite 200, Lewisville, TX 75067. ASD. Tel. Toll Free: (800) 275-3290. Phone: (469) 549-7100. Fax: (972) 906-1499. Web Site: [www.overheaddoor.com](http://www.overheaddoor.com). E-mail: [info@overheaddoor.com](mailto:info@overheaddoor.com).
- B. Requests for substitutions will be considered in accordance with provisions of Section 012500.

### 2.2 INSULATED SECTIONAL OVERHEAD DOORS

- A. Insulated Steel Sectional **Overhead Doors: 599 Series Thermacore** Insulated Steel Doors by Overhead Door Corporation. Units shall have the following characteristics:
  - 1. Door Assembly: Metal/foam/metal sandwich panel construction, with PVC thermal break and weather-tight ship-lap meeting joints.
    - a. Panel Thickness: 2 inches.
    - b. Exterior Surface: Flush, textured.
    - c. Exterior Steel: .015 inch, hot-dipped galvanized.
    - d. End Stiles: 16 gauge with thermal break.
    - e. Spring Counterbalance: Sized to weight of the door, with a helically wound, oil tempered torsion spring mounted on a steel shaft; cable drum of diecast aluminum with high strength galvanized aircraft cable. Sized with a minimum 7 to 1 safety factor.
      - 1. High cycle spring: 50,000 cycles.
    - f. Insulation: CFC-free and HCFC-free polyurethane, fully encapsulated.
    - g. Thermal Values: R-value of 17.50; U-value of 0.057.
    - h. Air Infiltration: 0.08 cfm at 15 mph; 0.08 cfm at 25 mph.
    - i. High-Usage Package: Provide high-usage package.
    - j. Full Glazed Aluminum Sash Panels:
      - 1. 1/2 inch Low E Insulated glazing.
  - 2. Finish and Color: Two coat baked-on polyester.
    - a. Interior color, tan.
    - b. Exterior color, tan.
  - 3. Windload Design: Provide to meet the Design/Performance requirements specified.
  - 4. Hardware: Galvanized steel hinges and fixtures. Ball bearing rollers with hardened steel races.
  - 5. Lock:
    - a. Keyed lock with interlock switch for automatic operator.
  - 6. Weatherstripping:

- a. EPDM bulb-type strip at bottom section.
  - b. Flexible Jamb seals.
  - c. Flexible Header seal.
7. Track: Provide track as recommended by manufacturer to suit loading required and clearances available.
- a. Size: 2 inch.
  - b. Type: Standard lift, low headroom.
8. Electric Motor Operation: Provide UL listed 1/2 HP electric operator, to move door in either direction at not less than 2/3 foot nor more than 1 foot per second. Operator shall meet UL325/2010 requirements for continuous monitoring of safety devices.
- a. Entrapment Protection: Required for momentary contact.
    - 1. Electric sensing edge monitored to meet UL 325/2010.
    - 2. Photoelectric sensors monitored to meet UL 325/2010.
  - b. Operator Controls:
    - 1. Push-button and key operated control stations with open, close, and stop buttons.
    - 2. Flush mounting.
    - 3. Both interior and exterior location.

## PART 3 - EXECUTION

### 3.1 EXAMINATION

- A. Do not begin installation until openings have been properly prepared.
- B. Verify wall openings are ready to receive work and opening dimensions and tolerances are within specified limits.
- C. Verify electric power is available and of correct characteristics.
- D. If preparation is the responsibility of another installer, notify Owner of unsatisfactory preparation before proceeding.

### 3.2 PREPARATION

- A. Clean surfaces thoroughly prior to installation.
- B. Prepare surfaces using the methods recommended by the manufacturer for achieving the best result for the substrate under the project conditions.

### 3.3 INSTALLATION

- A. Install overhead doors and track in accordance with approved shop drawings and the manufacturer's printed instructions.
- B. Coordinate installation with adjacent work to ensure proper clearances and allow for maintenance.
- C. Anchor assembly to wall construction and building framing without distortion or stress.
- D. Securely brace door tracks suspended from structure. Secure tracks to structural members only.
- E. Fit and align door assembly including hardware.
- F. Coordinate installation of electrical service. Complete power and control wiring from disconnect to unit components.

### 3.4 CLEANING AND ADJUSTING

- A. Adjust door assembly to smooth operation and in full contact with weatherstripping.
- B. Clean doors, frames and glass.
- C. Remove temporary labels and visible markings.

### 3.5 PROTECTION

- A. Do not permit construction traffic through overhead door openings after adjustment and cleaning.
- B. Protect installed products until completion of project.
- C. Touch-up, damaged coatings and finishes and repair minor damage before Substantial Completion.

\*\* END OF SECTION \*\*

**SECTION 100070  
ALUMINUM FRAMED  
ENTRANCES AND STOREFRONTS**

**PART 1 - GENERAL**

**1.1 RELATED DOCUMENTS**

- A. Drawings and general provisions of the Contract, including General and Supplementary Conditions and Division 01 Specification Sections, apply to this Section.

**1.2 SUMMARY**

- A. Section Includes:
  - 1. Exterior and interior manual swing entrance doors and door frame units.

**1.3 DEFINITIONS**

- A. ADA/ABA Accessibility Guidelines: U.S. Architectural & Transportation Barriers Compliance Board's "Americans with Disability Act (ADA) and Architectural Barriers Act (ABA) Accessibility Guidelines for Buildings and Facilities."

**1.4 PERFORMANCE REQUIREMENTS**

- A. General Performance: Aluminum framed systems shall withstand the effects of the following performance requirements without exceeding performance criteria or failure due to defective manufacture, fabrication, installation, or other defects in construction:
  - 1. Movements of supporting structure indicated on Drawings including, but not limited to, story drift and deflection from uniformly distributed and concentrated live loads.
  - 2. Dimensional tolerances of building frame and other adjacent construction.
  - 3. Failure includes the following:
    - a. Deflection exceeding specified limits.
    - b. Thermal stresses transferring to building structure.
    - c. Framing members transferring stresses, including those caused by thermal and structural movements to glazing.
    - d. Glazing-to-glazing contact.
    - e. Noise or vibration created by wind and by thermal and structural movements.
    - f. Loosening or weakening of fasteners, attachments, and other components.
    - g. Sealant failure.
    - h. Failure of operating units.
- B. Delegated Design: Design aluminum framed systems, including comprehensive engineering analysis by a qualified professional engineer, using performance requirements and design criteria indicated.

- C. Structural Loads:
1. Wind Loads:
  2. Seismic Loads:
  3. Blast Loads:
- D. Deflection of Framing Members:
1. Deflection Normal to Wall Plane: Limited to  $1/175$  of clear span for spans up to 13 feet 6 inches and to  $1/240$  of clear span plus  $1/4$  inch for spans greater than 13 feet 6 inches or an amount that restricts edge deflection of individual glazing lites to  $3/4$  inch, whichever is less.
  2. Deflection Parallel to Glazing Plane: Limited to  $L/360$  of clear span or  $1/8$  inch, whichever is smaller.
- E. Structural Test Performance: Provide aluminum framed systems tested according to ASTM E 330 as follows:
1. When tested at positive and negative wind-load design pressures, systems do not evidence deflection exceeding specified limits.
  2. When tested at 150 percent of positive and negative wind-load design pressures, systems, including anchorage, do not evidence material failures, structural distress, and permanent deformation of main framing members exceeding 0.2 percent of span.
  3. Test Durations: As required by design wind velocity, but not fewer than 10 seconds.
- F. Story Drift: Provide aluminum framed systems that accommodate design displacement of adjacent stories indicated.
1. Design Displacement:
  2. Test Performance: Meet criteria for passing, based on building occupancy type, when tested according to AAMA 501.4 at design displacement and 1.5 times design displacement.
- G. Air Infiltration: Provide aluminum framed systems with maximum air leakage through fixed glazing and framing areas of 0.06 cfm/sq. ft. of fixed wall area when tested according to ASTM E 283 at a minimum static-air-pressure difference of 1.57 lbf/sq. ft.
- H. Water Penetration under Static Pressure: Provide aluminum framed systems that do not evidence water penetration through fixed glazing and framing areas when tested according to ASTM E 331 at a minimum static-air-pressure difference of 20 percent of positive wind-load design pressure, but not less than 6.24 lbf/sq. ft.
- I. Water Penetration under Dynamic Pressure: Provide aluminum framed systems that do not evidence water leakage through fixed glazing and framing areas when tested according to AAMA 501.1 under dynamic pressure equal to 20 percent of positive wind-load design pressure, but not less than 6.24 lbf/sq. ft.
1. Maximum Water Leakage: No uncontrolled water penetrating aluminum framed systems or water appearing on systems' normally exposed interior surfaces from sources other than condensation. Water leakage does not include water controlled by flashing and



gutters that is drained to exterior and water that cannot damage adjacent materials or finishes.

- J. Thermal Movements: Provide aluminum framed systems that allow for thermal movements resulting from the following maximum change (range) in ambient and surface temperatures. Base engineering calculation on surface temperatures of materials due to both solar heat gain and nighttime-sky heat loss.
  - 1. Temperature Change (Range): 120 deg F, ambient; 180 deg F, material surfaces.
  - 2. Test Performance: No buckling; stress on glass; sealant failure; excess stress on framing, anchors, and fasteners; or reduction of performance when tested according to AAMA 501.5.
    - a. High Exterior Ambient-Air Temperature: That which produces an exterior metal-surface temperature of 180 deg F.
    - b. Low Exterior Ambient-Air Temperature: 0 deg F.
  - 3. Interior Ambient-Air Temperature: 75 deg F.
- K. Condensation Resistance: Provide aluminum framed systems with fixed glazing and framing areas having condensation-resistance factor (CRF) of not less than 53 when tested according to AAMA 1503.
- L. Thermal Conductance: Provide aluminum framed systems with fixed glazing and framing areas having an average U-factor of not more than 0.57 Btu/sq. ft. x h x deg F when tested according to AAMA 1503.
- M. Sound Transmission: Provide aluminum framed systems with fixed glazing and framing areas having the following sound-transmission characteristics:
  - 1. Sound Transmission Class (STC): Minimum 30 STC when tested for laboratory sound transmission loss according to ASTM E 90 and determined by ASTM E 413.
- N. Structural Sealant: Capable of withstanding tensile and shear stresses imposed by aluminum framed systems without failing adhesively or cohesively. When tested for preconstruction adhesion and compatibility, cohesive failure of sealant shall occur before adhesive failure.
  - 1. Adhesive failure occurs when sealant pulls away from substrate cleanly, leaving no sealant material behind.
  - 2. Cohesive failure occurs when sealant breaks or tears within itself but does not separate from each substrate because sealant-to-substrate bond strength exceeds sealant's internal strength.
- O. Structural-Sealant Joints: Designed to produce tensile or shear stress of less than 20 psi.

## 1.5 ACTION SUBMITTALS

- A. Product Data: For each type of product indicated. Include construction details, material descriptions, dimensions of individual components and profiles, and finishes for aluminum framed systems.

- B. Shop Drawings: For aluminum framed systems. Include plans, elevations, sections, details, and attachments to other work.
  - 1. Include details of provisions for system expansion and contraction and for drainage of moisture in the system to the exterior.
  - 2. For entrance doors, include hardware schedule and indicate operating hardware types, functions, quantities, and locations.
- C. Samples for Verification: For each type of exposed finish required, in Manufacturer's standard sizes.
- D. Fabrication Sample: Of each vertical-to-horizontal intersection of aluminum framed systems, made from 12-inch lengths of full-size components and showing details of the following:
  - 1. Joinery, including concealed welds.
  - 2. Anchorage.
  - 3. Expansion provisions.
  - 4. Glazing.
  - 5. Flashing and drainage.
- E. Other Action Submittals:
  - 1. Entrance Door Hardware Schedule: Prepared by or under the supervision of supplier, detailing fabrication and assembly of entrance door hardware, as well as procedures and diagrams. Coordinate final entrance door hardware schedule with doors, frames, and related work to ensure proper size, thickness, hand, function, and finish of entrance door hardware.
- F. Delegated Design Submittal: For aluminum framed systems indicated to comply with performance requirements and design criteria, including analysis data signed and sealed by the qualified professional engineer responsible for their preparation.
  - 1. Detail fabrication and assembly of aluminum framed systems.
  - 2. Include design calculations.

## 1.6 INFORMATIONAL SUBMITTALS

- A. Qualification Data: For qualified Installer and testing agency.
- B. Seismic Qualification Certificates: For aluminum framed systems, accessories, and components, from Manufacturer.
  - 1. Basis for Certification: Indicate whether withstand certification is based on actual test of assembled components or on calculation.
- C. Welding certificates.
- D. Preconstruction Test Reports: For sealant.

- E. Product Test Reports: Based on evaluation of comprehensive tests performed by a qualified testing agency, for aluminum framed systems, indicating compliance with performance requirements.
- F. Source quality-control reports.
- G. Quality Control Program for Structural Sealant Glazed System: Include reports.
- H. Field quality-control reports.
- I. Warranties: Sample of special warranties.

#### 1.7 CLOSEOUT SUBMITTALS

- A. Maintenance Data: For aluminum framed systems to include in maintenance manuals.

#### 1.8 QUALITY ASSURANCE

- A. Installer Qualifications: Manufacturer's authorized representative who is trained and approved for installation of units required for this Project.
- B. Testing Agency Qualifications: Qualified according to ASTM E 699 for testing indicated.
- C. Engineering Responsibility: Prepare data for aluminum framed systems, including Shop Drawings, based on testing and engineering analysis of Manufacturer's standard units in systems similar to those indicated for this Project.
- D. Quality Control Program for Structural Sealant Glazed System: Develop quality control program specifically for Project. Document quality-control procedures and verify results for aluminum framed systems. Comply with ASTM C 1401 recommendations including, but not limited to, system material-qualification procedures, preconstruction sealant-testing program, procedures for system fabrication and installation, and intervals of reviews and checks.
- E. Product Options: Information on Drawings and in Specifications establishes requirements for systems' aesthetic effects and performance characteristics. Aesthetic effects are indicated by dimensions, arrangements, alignment, and profiles of components and assemblies as they relate to sightlines, to one another, and to adjoining construction. Performance characteristics are indicated by criteria subject to verification by one or more methods including preconstruction testing, field testing, and in-service performance.
  - 1. Do not revise intended aesthetic effects, as judged solely by Owner, except with Owner's approval. If revisions are proposed, submit comprehensive explanatory data to Owner for review.
- F. Pre-construction Sealant Testing: For structural sealant glazed systems, perform sealant Manufacturer's standard tests for compatibility with and adhesion of each material that will come in contact with sealants and each condition required by aluminum framed systems.
  - 1. Test a minimum five samples each of metal, glazing, and other material.
  - 2. Prepare samples using techniques and primers required for installed systems.

3. For materials that fail tests, determine corrective measures necessary to prepare each material to ensure compatibility with and adhesion of sealants including, but not limited to, specially formulated primers. After performing these corrective measures on the minimum number of samples required for each material, retest materials.
- G. Accessible Entrances: Comply with applicable provisions in the U.S. Architectural & Transportation Barriers Compliance Board's ADA-ABA Accessibility Guidelines and ICC/ANSI A117.1.
  - H. Source Limitations for Aluminum framed Systems: Obtain from single source from single Manufacturer.
  - I. Structural Sealant Glazing: Comply with ASTM C 1401, "Guide for Structural Sealant Glazing" for design and installation of structural-sealant-glazed systems.
  - J. Structural Sealant Joints: Design reviewed and approved by structural-sealant Manufacturer.
  - K. Welding Qualifications: Qualify procedures and personnel according to AWS D1.2, "Structural Welding Code - Aluminum."
  - L. Mockups: Build mockups to verify selections made under sample submittals and to demonstrate aesthetic effects and set quality standards for fabrication and installation.
    1. Build mockup of typical wall area.
    2. Field testing shall be performed on mockups according to requirements in "Field Quality Control" Article.
    3. Approval of mockups does not constitute approval of deviations from the Contract Documents contained in mockups unless Owner specifically approves such deviations in writing.
    4. Approved mockups may become part of the completed Work if undisturbed at time of Substantial Completion.
  - M. Pre-installation Conference: Conduct conference at Project site.

## 1.9 PROJECT CONDITIONS

- A. Field Measurements: Verify actual locations of structural supports for aluminum framed systems by field measurements before fabrication and indicate measurements on Shop Drawings.

## 1.10 WARRANTY

- A. Special Warranty: Manufacturer's standard form in which Manufacturer agrees to repair or replace components of aluminum framed systems that do not comply with requirements or that fail in materials or workmanship within specified warranty period.
  1. Failures include, but are not limited to, the following:
    - a. Structural failures including, but not limited to, excessive deflection.
    - b. Noise or vibration caused by thermal movements.

- c. Deterioration of metals, metal finishes, and other materials beyond normal weathering.
  - d. Adhesive or cohesive sealant failures.
  - e. Water leakage through fixed glazing and framing areas.
  - f. Failure of operating components.
2. Warranty Period: **5 years** from date of Substantial Completion.

#### 1.11 MAINTENANCE SERVICE

##### A. Entrance Door Hardware:

- 1. Maintenance Tools and Instructions: Furnish a complete set of specialized tools and maintenance instructions as needed for Owner's continued adjustment, maintenance, and removal and replacement of entrance door hardware.
- 2. Initial Maintenance Service: Beginning at Substantial Completion, provide six months' full maintenance by skilled employees of entrance door hardware Installer. Include quarterly preventive maintenance, repair or replacement of worn or defective components, lubrication, cleaning, and adjusting as required for proper entrance door hardware operation at rated speed and capacity. Provide parts and supplies the same as those used in the manufacture and installation of original equipment.

### PART 2 - PRODUCTS

#### 2.1 MANUFACTURERS

- A. Basis-of-Design Storefront Product: Subject to compliance with requirements, provide **YKK AP America Inc YES 45 TU** Series Storefront or comparable product by one of the following:
  - 1. Kawneer.
  - 2. US Aluminum, Division of CR Lawrence.
  - 3. Old Castle Building Envelope.
- B. Basis-of-Design Entrance Product: Subject to compliance with requirements, provide **YKK AP America Inc 35D** Series Medium Stile Swing Doors with 10" Bottom Rail (coordinate medium stile with hardware supplied) or comparable product by one of the following:
  - 1. Kawneer.
  - 2. US Aluminum, Division of CR Lawrence.
  - 3. Old Castle Building Envelope.

#### 2.2 MATERIALS

- A. Aluminum: Alloy and temper recommended by Manufacturer for type of use and finish indicated.
  - 1. Sheet and Plate: ASTM B 209.
  - 2. Extruded Bars, Rods, Profiles, and Tubes: ASTM B 221.

3. Extruded Structural Pipe and Tubes: ASTM B 429.
  4. Structural Profiles: ASTM B 308.
  5. Welding Rods and Bare Electrodes: AWS A5.10.
- B. Steel Reinforcement: Manufacturer's standard zinc-rich, corrosion-resistant primer, complying with SSPC-PS Guide No. 12.00; applied immediately after surface preparation and pretreatment. Select surface preparation methods according to recommendations in SSPC-SP COM and prepare surfaces according to applicable SSPC standard.
1. Structural Shapes, Plates, and Bars: ASTM A 36.
  2. Cold-Rolled Sheet and Strip: ASTM A 1008.
  3. Hot-Rolled Sheet and Strip: ASTM A 1011.

## 2.3 FRAMING SYSTEMS

- A. Framing Members: Manufacturer's standard extruded-aluminum framing members of thickness required and reinforced as required to support imposed loads.
1. Construction: Thermally broken.
  2. Glazing System: Retained mechanically with gaskets on four sides.
  3. Glazing Plane: Center.
- B. Brackets and Reinforcements: Manufacturer's standard high strength aluminum with non-staining, nonferrous shims for aligning system components.
- C. Fasteners and Accessories: Manufacturer's standard corrosion-resistant, non-staining, non-bleeding fasteners and accessories compatible with adjacent materials.
1. Use self-locking devices where fasteners are subject to loosening or turning out from thermal and structural movements, wind loads, or vibration.
  2. Reinforce members as required to receive fastener threads.
  3. Use exposed fasteners with countersunk Phillips screw heads, finished to match framing system, fabricated from stainless steel.
- D. Concrete and Masonry Inserts: Hot-dip galvanized cast-iron, malleable-iron, or steel inserts, complying with ASTM A 123 or ASTM A 153.
- E. Concealed Flashing: Dead-soft, 0.018-inch thick stainless steel, ASTM A 240 of type recommended by Manufacturer.
- F. Shim Supports: Custom continuous pre-finished aluminum shim supports attached to aluminum frame to retain secondary sealant application specified in Section 079200. Shim support to be mechanically attached to main aluminum frame member at head, jambs, and sill on all aluminum frames to support secondary compression sealant.
- G. Framing System Gaskets and Sealants: Manufacturer's standard, recommended by Manufacturer for joint type.
1. Sealants used inside the weatherproofing system shall have a VOC content of 250 g/L or less when calculated according to 40 CFR 59, Subpart D (EPA Method 24).

2. Sealants used inside the weatherproofing system shall comply with the testing and product requirements of the California Department of Health Services' "Standard Practice for the Testing of Volatile Organic Emissions from Various Sources Using Small-Scale Environmental Chambers."

## 2.4 GLAZING SYSTEMS

- A. Glazing: As specified in Division 24 Section "Glazing."
- B. Glazing Gaskets: Manufacturer's standard compression types; replaceable, molded or extruded, of profile and hardness required to maintain watertight seal.
- C. Spacers and Setting Blocks: Manufacturer's standard elastomeric type.
- D. Bond Breaker Tape: Manufacturer's standard TFE-fluorocarbon or polyethylene material to which sealants will not develop adhesion.
- E. Glazing Sealants: For structural-sealant-glazed systems, as recommended by Manufacturer for joint type, and as follows:
  1. Structural Sealant: ASTM C 1184, single-component neutral-curing silicone formulation that is compatible with system components with which it comes in contact, specifically formulated and tested for use as structural sealant and approved by a structural-sealant Manufacturer for use in aluminum framed systems indicated.
    - a. Sealants used inside the weatherproofing system shall have a VOC content of 100 g/L or less when calculated according to 40 CFR 59, Subpart D (EPA Method 24).
    - b. Sealants used inside the weatherproofing system shall comply with the testing and product requirements of the California Department of Health Services' "Standard Practice for the Testing of Volatile Organic Emissions from Various Sources Using Small-Scale Environmental Chambers."
    - c. Color: Black.
  2. Weather-seal Sealant: ASTM C 920 for Type S, Grade NS, Class 25, Uses NT, G, A, and O; single-component neutral-curing formulation that is compatible with structural sealant and other system components with which it comes in contact; recommended by structural-sealant, weather-seal-sealant, and aluminum framed-system Manufacturers for this use.
    - a. Sealants used inside the weatherproofing system shall have a VOC content of 250 g/L or less when calculated according to 40 CFR 59, Subpart D (EPA Method 24).
    - b. Sealants used inside the weatherproofing system shall comply with the testing and product requirements of the California Department of Health Services' "Standard Practice for the Testing of Volatile Organic Emissions from Various Sources Using Small-Scale Environmental Chambers."
    - c. Color: Matching structural sealant.

## 2.5 ENTRANCE DOOR SYSTEMS

- A. Entrance Doors: Manufacturer's standard glazed entrance doors for manual-swing operation.
  - 1. Door Construction: 2-3/8 inch overall thickness, with minimum 0.125 inch thick, extruded-aluminum tubular rail and stile members. Mechanically fasten corners with reinforcing brackets that are deeply penetrated and fillet welded or that incorporate concealed tie rods.
    - a. Thermal Construction: High-performance plastic connectors separate aluminum members exposed to the exterior from members exposed to the interior.
  - 2. Door Design: Medium stile; 3-1/2-inch nominal width.
    - a. Accessible Doors: Smooth surfaced for width of door in area within 10 inches above floor or ground plane.
  - 3. Glazing Stops and Gaskets: Square, snap-on, extruded-aluminum stops and preformed gaskets.
    - a. Provide non-removable glazing stops on outside of door.
- B. Entrance Door Hardware: As specified in Section 10 "Door Hardware."

## 2.6 ENTRANCE DOOR HARDWARE

- A. General: Provide entrance door hardware and entrance door hardware sets indicated in door and frame schedule.
  - 1. Entrance Door Hardware Sets: Provide quantity, item, size, finish or color indicated.
  - 2. Opening Force Requirements:
    - a. Egress Doors: Not more than 15 lbf to release the latch and not more than 30 lbf to set the door in motion and not more than 15 lbf to open the door to its minimum required width.
    - b. Accessible Interior Doors: Not more than 5 lbf to fully open door.

## 2.7 STOREFRONT SYSTEM

- A. General: Manufacturer's standard extruded aluminum sections and components for complete storefront system.

## 2.8 ACCESSORY MATERIALS

- A. Joint Sealants: For installation at perimeter of aluminum framed systems, as specified in Division 24 Section "Joint Sealants."
  - 1. Sealants used inside the weatherproofing system shall have a VOC content of 250 g/L or less when calculated according to 40 CFR 59, Subpart D (EPA Method 24).



2. Sealants used inside the weatherproofing system shall comply with the testing and product requirements of the California Department of Health Services' "Standard Practice for the Testing of Volatile Organic Emissions from Various Sources Using Small-Scale Environmental Chambers."

- B. Bituminous Paint: Cold-applied, asphalt-mastic paint complying with SSPC-Paint 12 requirements except containing no asbestos; formulated for 30-mil thickness per coat.

## 2.9 FABRICATION

- A. Form or extrude aluminum shapes before finishing.
- B. Weld in concealed locations to greatest extent possible to minimize distortion or discoloration of finish. Remove weld spatter and welding oxides from exposed surfaces by de-scaling or grinding.
- C. Framing Members, General: Fabricate components that, when assembled, have the following characteristics:
  1. Profiles that are sharp, straight, and free of defects or deformations.
  2. Accurately fitted joints with ends coped or mitered.
  3. Means to drain water passing joints, condensation within framing members, and moisture migrating within the system to exterior.
  4. Physical and thermal isolation of glazing from framing members.
  5. Accommodations for thermal and mechanical movements of glazing and framing to maintain required glazing edge clearances.
  6. Provisions for field replacement of glazing from exterior.
  7. Fasteners, anchors, and connection devices that are concealed from view to greatest extent possible.
- D. Mechanically Glazed Framing Members: Fabricate for flush glazing without projecting stops.
- E. Structural Sealant Glazed Framing Members: Include accommodations for using temporary support device to retain glazing in place while structural sealant cures.
- F. Storefront Framing: Fabricate components for assembly using shear block system.
- G. Entrance Door Frames: Reinforce as required to support loads imposed by door operation and for installing entrance door hardware.
  1. At exterior doors, provide compression weather stripping at fixed stops.
  2. At interior doors, provide silencers at stops to prevent metal-to-metal contact. Install three silencers on strike jamb of single-door frames and two silencers on head of frames for pairs of doors.
- H. Entrance Doors: Reinforce doors as required for installing entrance door hardware.
  1. At exterior doors, provide weather sweeps applied to door bottoms.

- I. Entrance Door Hardware Installation: Factory install entrance door hardware to the greatest extent possible. Cut, drill, and tap for factory-installed entrance door hardware before applying finishes.
- J. After fabrication, clearly mark components to identify their locations in Project according to Shop Drawings.

## 2.10 ALUMINUM FINISHES

- A. **Clear Anodic Finish:** AAMA 611, AA-M12C22A41, Class I, 0.018 mm or thicker.

## PART 3 - EXECUTION

### 3.1 EXAMINATION

- A. Examine areas and conditions, with Installer present, for compliance with requirements for installation tolerances and other conditions affecting performance of the Work.
- B. Proceed with installation only after unsatisfactory conditions have been corrected.

### 3.2 INSTALLATION

- A. General:
  - 1. Comply with Manufacturer's written instructions.
  - 2. Do not install damaged components.
  - 3. Fit joints to produce hairline joints free of burrs and distortion.

4. Rigidly secure non-movement joints.
5. Install anchors with separators and isolators to prevent metal corrosion and electrolytic deterioration.
6. Seal joints watertight unless otherwise indicated.

B. Metal Protection:

1. Where aluminum will contact dissimilar metals, protect against galvanic action by painting contact surfaces with primer or applying sealant or tape, or by installing nonconductive spacers as recommended by Manufacturer for this purpose.
2. Where aluminum will contact concrete or masonry, protect against corrosion by painting contact surfaces with bituminous paint.

C. Install components to drain water passing joints, condensation occurring within framing members, and moisture migrating within the system to exterior.

D. Set continuous sill members and flashing in full sealant bed as specified in Section 24 Section "Joint Sealants" to produce weather-tight installation.

E. Install components plumb and true in alignment with established lines and grades, and without warp or rack.

F. Install glazing as specified in Section 24 "Glazing."

G. Entrance Doors: Install doors to produce smooth operation and tight fit at contact points.

1. Exterior Doors: Install to produce weather-tight enclosure and tight fit at weather stripping.
2. Field Installed Entrance Door Hardware: Install surface mounted entrance door hardware according to entrance door hardware Manufacturers' written instructions using concealed fasteners to greatest extent possible.

H. Install perimeter joint sealants as specified in Section 24 "Joint Sealants" to produce weather-tight installation.

### 3.3 ERECTION TOLERANCES

A. Install aluminum framed systems to comply with the following maximum erection tolerances:

1. Location and Plane: Limit variation from true location and plane to 1/8 inch in 12 feet; 1/4 inch over total length.
2. Alignment:
  - a. Where surfaces abut in line, limit offset from true alignment to 1/16 inch.
  - b. Where surfaces meet at corners, limit offset from true alignment to 1/32 inch.

B. Diagonal Measurements: Limit difference between diagonal measurements to 1/8 inch.

### 3.4 FIELD QUALITY CONTROL

- A. Testing Agency: **Engage** a qualified independent testing and inspecting agency to perform field tests and inspections.
- B. Testing Services: Testing and inspecting of representative areas to determine compliance of installed systems with specified requirements shall take place as follows and in successive phases as indicated on Drawings. Do not proceed with installation of the next area until test results for previously completed areas show compliance with requirements.
  - 1. Air Infiltration: Areas shall be tested for air leakage of 1.5 times the rate specified for laboratory testing under "Performance Requirements" Article, but not more than 0.09 cfm/sq. ft., of fixed wall area when tested according to ASTM E 783 at a minimum static-air-pressure difference of 6.24 lbf/sq. ft.
  - 2. Water Penetration: Areas shall be tested according to ASTM E 1105 at a minimum uniform and cyclic static-air-pressure difference of 0.67 times the static-air-pressure difference specified for laboratory testing under "Performance Requirements" Article, but not less than 4.18 lbf/sq. ft., and shall not evidence water penetration.
  - 3. Water Spray Test: Before installation of interior finishes has begun, a minimum area of 75 feet by 1 story of aluminum framed systems designated by Owner shall be tested according to AAMA 501.2 and shall not evidence water penetration.
- C. Repair or remove work if test results and inspections indicate that it does not comply with specified requirements.
- D. Additional testing and inspecting, at Contractor's expense, will be performed to determine compliance of replaced or additional work with specified requirements.
- E. Aluminum framed assemblies will be considered defective if they do not pass tests and inspections.
- F. Prepare test and inspection reports.

### 3.5 ADJUSTING

- A. Adjust operating entrance door hardware to function smoothly as recommended by Manufacturer.
  - 1. For entrance doors accessible to people with disabilities, adjust closers to provide a 3-second closer sweep period for doors to move from a 70-degree open position to 3 inches from the latch, measured to the leading door edge.

\*\* END OF SECTION \*\*

**SECTION 100080  
FIRE RATED ENTRANCES  
AND STOREFRONTS**

**PART 1 - GENERAL**

**1.1 Summary**

**A. Section Includes:**

1. Fire rated curtain wall system, including perimeter trims, stools, accessories, shims and anchors, and perimeter sealing of curtain wall framing.

**B. Related Sections include the following:**

1. Section 10 "Aluminum Framed Entrances and Storefronts" for entrances installed in non-rated applications.
2. Section 10 "Door Hardware" for door hardware for all entrances.
3. Section 24 "Glazing" for glazing in fire rated applications.

**1.2 REFERENCES**

**A. American Architectural Manufacturers Association (AAMA)**

1. AAMA 501.1-2005: Standard Test Method for Water Penetration of Windows, Curtain Walls, and Doors Using Dynamic Pressure
2. AAMA 501.2-2003: Quality Assurance and Diagnostic Water Leakage Field Check of Installed Storefronts, Curtain Walls, and Sloped Glazing Systems
3. AAMA 501.4-2000 (Revised 2001): Recommended Static Test Method for Evaluating Curtain Wall and Storefront Systems Subjected to Seismic and Wind Induced Interstory Drifts
4. AAMA 501.5-2005: Test Method for Thermal Cycling of Exterior Walls
5. AAMA 506-2000 (Revised 2003): Voluntary Specifications for Hurricane Impact and Cycle Testing of Fenestration Products
6. AAMA 1503-1998: Voluntary Test Method for Thermal Transmittance and Condensation Resistance of Windows, Doors and Glazed Wall Sections
7. AAMA 2603-2002 - Voluntary Specification, Performance Requirements and Test Procedures for Pigmented Organic Coatings on Aluminum Extrusions and Panels.
8. AAMA 2604-2005 - Voluntary Specification, Performance Requirements and Test Procedures for High Performance Organic Coatings on Aluminum Extrusions and Panels.
9. AAMA 2605-2005 - Voluntary Specification, Performance Requirements and Test Procedures for Superior Performing Organic Coatings on Aluminum Extrusions and Panels.

**B. American Society for Testing and Materials (ASTM):**

1. Fire safety related:
  - a. ASTM E119: Methods for Fire Tests of Building Construction and Materials.

- b. ASTM E2074-00: Standard Test Method for Fire Tests of Door Assemblies, Including Positive Pressure Testing of Side-Hinged and Pivoted Swinging Door Assemblies.
  - c. ASTM E2010-01: Standard Test Method for Positive Pressure Fire Tests of Window Assemblies.
- 2. Material related
  - a. ASTM A 1008 - Standard Specification for Steel, Sheet, Cold-Rolled, Carbon, Structural, High-Strength, Low Alloy, and High-Strength Low-Alloy with Improved Formability, Solution Hardened, and Bake Hardenable; 2007.
  - b. ASTM A 1011 - Standard Specification for Steel, Sheet and Strip, Hot-Rolled, Carbon, Structural, High-Strength Low-Alloy and High-Strength Low-Alloy with Improved Formability, and Ultra-High Strength; 2006b.
- 3. Exterior related
  - a. ASTM E 283-04: Test Method for Determining the Rate of Air Leakage through Exterior Windows, Curtain Walls, and Doors under Specified Pressure Differences across the Specimen
  - b. ASTM E 330-02: Test Method for Structural Performance of Exterior Windows, Doors, Skylights and Curtain Walls by Uniform Static Air Pressure Difference Procedure A
  - c. ASTM E 331-04: Test Method for Water Penetration of Exterior Windows, Skylights, Doors, and Curtain Walls by Uniform Static Air Pressure Difference
  - d. ASTM E 783-02: Test Method for Field Measurement of Air Leakage through Installed Exterior Windows and Doors
  - e. ASTM E 1105-00: Test Method for Field Determination of Water Penetration of Installed Exterior Windows, Skylights, Doors, and Curtain Walls by Uniform or Cyclic Static Air Pressure Difference
- 4. Sound related:
  - a. ASTM E 90-04: Test Method for Laboratory Measurement of Airborne Sound Transmission Loss of Building Partitions and Elements
  - b. ASTM E 413-04: Standard Classification for Rating Sound Insulation
- C. American Welding Society (AWS)
  - 1. AWS D1.3 - Structural Welding Code - Sheet Steel; 2007
- D. Builders Hardware Manufacturers Association, Inc
  - 1. BHMA A156 - American National Standards for door hardware; 2006 (ANSI/BHMA A156).
- E. National Fire Protection Association (NFPA):
  - 1. NFPA 80: Fire Doors and Windows.
  - 2. NFPA 251: Fire Tests of Building Construction & Materials
  - 3. NFPA 252: Fire Tests of Door Assemblies
  - 4. NFPA 257: Fire Test of Window Assemblies

- F. Underwriters Laboratories, Inc. (UL):
  - 1. UL 9: Fire Tests of Door Assemblies
  - 2. UL 10 B: Fire Tests of Door Assemblies
  - 3. UL 10 C: Positive Pressure Fire Tests of Window & Door Assemblies
  - 4. UL 263: Fire tests of Building Construction and Materials
- G. Uniform Building Code
  - 1. UBC 7-2 (1997) - Fire Tests of Door Assemblies, Parts I and II
  - 2. UBC 7-4 (1997) - Fire Tests of Window Assemblies
- H. American National Standards Institute (ANSI):
  - 1. ANSI Z97.1: Standard for Safety Glazing Materials Used in Buildings
- I. Consumer Product Safety Commission (CPSC):
  - 1. CPSC 16 CFR 1201: Safety Standard for Architectural Glazing Materials
- J. American Society of Civil Engineers (ASCE)
  - 1. ASCE 7 - Minimum Design Loads for Buildings and Other Structures;; 2005

### 1.3 PERFORMANCE REQUIREMENTS

- A. System Description:
  - 1. Steel fire rated glazed curtain wall system, outside glazed pressure plate, cover cap format.
  - 2. Face Width: 2 3/8 inch.
  - 3. Water Drainage:
    - a. System is vertically weeped. No joint plugs or weep holes at horizontal mullions. Horizontal gaskets are notched and received by vertical gaskets.
- B. Structural Loads:
  - 1. Uniform Wind Load: ASTM E 330; Static air design load of 40 psf applied in positive and negative direction; no deflection in excess of L/175 of span of any framing member at design load.
  - 2. At structural test load equal to 1.5 times specified design load, no glass breakage or permanent set in the framing members in excess of 0.2% of their clear spans shall occur.
- C. Air Infiltration: ASTM E 283; Air infiltration rate shall not exceed 0.06 cfm/ft<sup>2</sup> at a static air pressure differential of 6.24 psf.
- D. Water Resistance, (static): ASTM E 331; No leakage at a static air pressure differential of 30 psf as defined in AAMA 501.

- E. Water Resistance, (dynamic): AAMA 501.1; No leakage at an air pressure differential of 30 psf as defined in AAMA 501.
- F. Thermal Movements: Provide steel fire rated glazed curtain-wall systems that allow for thermal movements resulting from the following maximum change (range) in ambient and surface temperatures. Base engineering calculation on surface temperatures of materials due to both solar heat gain and nighttime-sky heat loss.
  - 1. Temperature Change (Range): 120 deg F, ambient; 180 deg F, material surfaces.

#### 1.4 SUBMITTALS

- A. Product Data: Include construction details, material descriptions, dimensions of individual components and profiles, and finishes for each type of product indicated.
- B. Shop Drawings: Prepared by or under the supervision of a qualified professional engineer detailing fabrication and assembly of steel fire rated glazed curtain-wall systems.
  - 1. Include structural analysis data signed and sealed by the qualified professional engineer responsible for their preparation.
- C. Samples for Initial Selection: For units with factory-applied color finishes.

#### 1.5 QUALITY ASSURANCE

- A. Installer Qualifications: Installer experienced (as determined by contractor) to perform work of this section who has specialized in the installation of work similar to that required for this project and who is acceptable to product Manufacturer.
  - 1. Engineering Responsibility: Preparation of data for glazed curtainwall systems including the following:
    - a. Shop Drawings based on testing and engineering analysis of Manufacturer's standard units in assemblies similar to those indicated for this Project and submission of reports of tests performed on Manufacturer's standard assemblies.
    - b. Shop Drawings and comprehensive engineering analysis by a qualified professional engineer.
- B. Manufacturer Qualifications: Manufacturer capable of providing field service representation during construction, approving acceptable installer and approving application method.
- C. Pre-Installation Meetings: Conduct pre-installation meeting to verify project requirements, substrate conditions, Manufacturer's installation instructions, and Manufacturer's warranty requirements.

#### 1.6 DELIVERY, STORAGE, AND HANDLING

- A. Ordering: Comply with Manufacturer's ordering instructions and lead-time requirements to avoid construction delays.



- B. Packing, Shipping, Handling, and Unloading: Deliver materials in Manufacturer's original, unopened, undamaged containers with identification labels intact.
- C. Storage and Protection: Store materials protected from exposure to harmful weather conditions. Handle material and components to avoid damage. Protect curtainwall material against damage from elements, construction activities, and other hazards before, during and after curtainwall installation.

## 1.7 PROJECT CONDITIONS

- A. Field Measurements: Verify actual locations of structural supports for steel fire rated glazed curtain-wall systems by field measurements before fabrication and indicate measurements on Shop Drawings.
  - 1. Established Dimensions: Where field measurements cannot be made without delaying the Work, establish dimensions and proceed with fabricating steel fire rated glazed curtain-wall systems without field measurements. Coordinate construction to ensure that actual dimensions correspond to established dimensions.

## 1.8 WARRANTY

- A. Assembly Warranty: Manufacturer's standard form in which Manufacturer agrees to repair or replace components of steel fire rated glazed curtain-wall systems that do not comply with requirements or that deteriorate as defined in this Section within specified warranty period.
  - 1. Failures include, but are not limited to, the following:
    - a. Structural failures including, but not limited to, excessive deflection.
    - b. Noise or vibration caused by thermal movements.
    - c. Deterioration of metals, metal finishes, and other materials beyond normal weathering.
    - d. Water leakage.
    - e. Failure of operating components to function normally.
  - 2. Provide **Firelite** glass supplier's limited five year warranty from the date of shipment from the factory.
- B. Finish Warranty: Manufacturer's standard form in which Manufacturer agrees to repair or replace components on which finishes fail within specified warranty period. Warranty does not include normal weathering.
  - 1. Warranty Period: **2 years** from date of substantial completion.

## PART 2 - PRODUCTS

### 2.6 PRODUCTS GENERAL

- A. Frame System: **Fireframes® Curtainwall Series 120M** fire rated steel frame system as supplied by **Technical Glass Products** 8107 Bracken Place SE, Snoqualmie, WA 98065 (800-426-0279) fax (800-451-9857) e-mail [sales@fireglass.com](mailto:sales@fireglass.com) web site <http://www.fireglass.com>.
- B. Entrance System: **Fireframes® Designer Series 90M** fire rated steel frame system as supplied by **Technical Glass Products** 8107 Bracken Place SE, Snoqualmie, WA 98065 (800-426-0279) fax (800-451-9857) e-mail [sales@fireglass.com](mailto:sales@fireglass.com) web site <http://www.fireglass.com>.
- C. Refer to attached Manufacturer’s catalog cut sheets of curtainwall and designer series products.
- D. Refer to Door Schedule for door and frame elevations.
- E. Substitutions: No substitutions allowed.

## 2.7 HARDWARE

- A. Provide complete hardware package included as part of the Fire Rated Entrance System from **TGP** except for Hardware listed in Section 087100 “Door Hardware”. Hardware provided as part of the **TGP** package to be compatible with fail safe hardware specified in Section 087100 and to match finish specified for other hardware in Section 087100. Fire Rated Entrance door system to operate in a fail safe mode. GC to provide all hardware and power required for a fail safe operation.

## 2.8 MATERIALS - GLASS

- A. Fire Rated Glazing: ASTM C 1036 and ASTM C 1048.
- B. Thickness of Glazing Material: 1 inch insulated **Firelite Plus, 90M** at doors and **120M** at curtainwall framing.
- C. Logo: Each piece of fire rated glazing shall be labeled with a permanent logo including name of product, manufacture, testing laboratory (UL), fire rating period, safety glazing standards, and date of manufacture.

## 2.9 MATERIALS –STEEL FRAMING

- A. Steel Curtainwall Framing System **120 min.**
  - 1. Steel Frame: Profiled steel tubing permanently joined with steel bolts.
  - 2. Steel Pressure Plates: Formed stainless steel pressure plate with dimensions recommended by Manufacturer to securely hold glazing material in place.
- B. Aluminum: Alloy and temper recommended by Manufacturer for type of use and finish indicated.
  - 1. Extruded Bars, Rods, Shapes, and Tubes: ASTM B 221.
- C. Steel Reinforcement: With Manufacturer’s standard corrosion resistant primer complying with SSPC-PS Guide No. 12.00 applied immediately after surface preparation and pretreatment.

Select surface preparation methods according to recommendations in SSPC-SP COM and prepare surfaces according to applicable SSPC standard.

1. Structural Shapes, Plates, and Bars: ASTM A 36.
  2. Cold-Rolled Sheet and Strip: ASTM A 611.
  3. Hot-Rolled Sheet and Strip: ASTM A 570.
- D. Brackets and Reinforcements: Manufacturer's standard high-strength materials with non-staining, non-ferrous shims for aligning system components.
- E. Fasteners and Accessories: Manufacturer's standard corrosion-resistant, non-staining, non-bleeding fasteners and accessories compatible with adjacent materials.
1. Where fasteners are subject to loosening or turn out from thermal and structural movements, wind loads, or vibration, use self-locking devices.
  2. Reinforce members as required to receive fastener threads.
- F. Anchors: Three-way adjustable anchors that accommodate fabrication and installation tolerances in material and finish compatible with adjoining materials and recommended by Manufacturer.
1. Concrete and Masonry Inserts: Hot-dip galvanized cast-iron, malleable-iron, or steel inserts complying with ASTM A 123 or ASTM A 153 requirements.
- G. Concealed Flashing: Manufacturer's standard corrosion-resistant, non-staining, non-bleeding flashing compatible with adjacent materials.

## 2.10 ACCESSORIES

- A. Exposed Fasteners: Use fasteners fabricated from Type 304 stainless steel.
- B. Glazing Gaskets:
1. Exterior Applications: ASTM C 864; extruded EPDM rubber that provides for silicone adhesion.
  2. Interior Applications: Glaze Firelite glass with approved pure silicone sealant.

- C. Intumescent Tape: As supplied by frame Manufacturer.
- D. Setting Blocks: Calcium silicate.
- E. Perimeter Anchors: Steel or 316 Stainless steel when exposed.
- F. Flashings: As recommended by Manufacturer; same material and finish as cover caps.
- G. Silicone Sealant: One-Part Low Modulus, High Movement-Capable Sealant: Type S; Grade NS; Class 25 with additional movement capability of 100 percent in extension and 50 percent in compression (total 150 percent); Use (Exposure) NT; Uses (Substrates) M, G, A, and O as applicable. (Use-O joint substrates include: Metal factory-coated with a high-performance coating; galvanized steel; ceramic tile.)
  - 1. Available Products:
    - a. Dow Corning **790** - Dow Corning Corp.
- H. Intumescent Caulk: Single component, latex-based, intumescent caulk designed to stop passage of fire, smoke, and fumes through fire rated separations; permanently flexible after cure; will not support mold growth; flame spread/smoke developed 10/10.
  - 1. Available Products:
    - a. Firetemp CI - John-Manville.

## 2.11 SLAG-WOOL-FIBER/ROCK-WOOL-FIBER INSULATION

- A. Available Manufacturers:
  - 1. Fibrex Insulations Inc.
  - 2. Owens Corning.
  - 3. Thermafiber.
- B. Unfaced, Slag-Wool-Fiber/Rock-Wool-Fiber Board Insulation: ASTM C 612, maximum flame-spread and smoke-developed indexes of 15 and 0, respectively; passing ASTM E 136 for combustion characteristics; and of the following nominal density and thermal resistivity:
  - 1. Nominal density of 4 lb/cu. ft., Types IA and IB, thermal resistivity of 4 deg F x h x sq. ft./Btu x in. at 75 deg F.
  - 2. Fiber Color: Regular color, unless otherwise indicated.

## 2.12 FABRICATION

- A. General:
  - 1. Fabricate components per Manufacturer's installation instructions and with minimum clearances and shim spacing around perimeter of assembly, yet enabling installation and dynamic movement of perimeter seal.

2. Accurately fit and secure joints and corners. Make joints flush and weatherproof.
3. Prepare components to receive anchor devices.
4. Fabricate anchors.
5. Arrange fasteners and attachments to be concealed from view.

#### 2.13 FINISHES, GENERAL

- A. Comply with NAAMM's "Metal Finishes Manual for Architectural and Metal Products" for recommendations for applying and designating finishes.
- B. Appearance of Finished Work: Variations in appearance of abutting or adjacent pieces are acceptable. Noticeable variations in the same piece are not acceptable.

#### 2.14 INTERIOR STEEL FINISHES

- A. Color Coated Finish: Apply Manufacturer's standard powder coating finish system applied to factory assembled frames before shipping, complying with Manufacturer's written instructions for surface preparation including pretreatment, application, and minimum dry film thickness.
  1. Color and Gloss: To be **selected by Owner** from Manufacturer's full range to match finish color selected for other aluminum window and door products specified elsewhere.

#### 2.15 ALUMINUM FINISHES

- A. Finish designations prefixed by AA comply with the system established by the Aluminum Association for designating aluminum finishes.
- B. High-Performance Organic Finish (2-Coat Fluoropolymer): AA-C12C40R1x (Chemical Finish: cleaned with inhibited chemicals; Chemical Finish: conversion coating; Organic Coating: Manufacturer's standard 2-coat, thermocured system consisting of specially formulated inhibitive primer and fluoropolymer color topcoat containing not less than 70 percent polyvinylidene fluoride resin by weight). Prepare, pretreat, and apply coating to exposed metal surfaces to comply with AAMA 2604 and 2605 and with coating and resin Manufacturers' written instructions.
  1. Color and Gloss: To be **selected by Owner** from Manufacturer's full range to match finish color selected for other aluminum window and door products specified elsewhere.

### PART 3 - EXECUTION

#### 3.6 EXAMINATION

- A. Site Verification of Conditions: Verify substrate conditions (which have been previously installed under other sections) are acceptable for product installation in accordance with Manufacturer's instructions. Verify openings are sized to receive curtain wall system and sill plate is level in accordance with Manufacturer's acceptable tolerances.

1. Field Measurements: Verify actual measurements/openings by field measurements before fabrication; show recorded measurements on shop drawings. Coordinate field measurements, fabrication schedule with construction progress to avoid construction delays.

### 3.7 INSTALLATION

- A. General: Install curtain wall systems plumb, level, and true to line, without warp or rack of frames with Manufacturer's prescribed tolerances and installation instructions. Provide support and anchor in place.
- B. Install fireframe system by a specialty contractor with appropriate experience qualifications; and in strict accordance with the approved shop drawings. Employ experienced mechanics familiar with this type of specialized work.
- C. Glazing: Glass shall be outside glazed and held in place with stainless steel pressure plates anchored to the mullion using stainless steel fasteners spaced no greater than 12-inches on center.
- D. Install glazing in strict accordance with fire resistant glazing material Manufacturer's specifications. Field cutting or tampering is not permissible.
- E. Firmly pack perimeter of framing system to rough opening with mineral wool fire stop insulation or appropriately rated intumescent sealant.

### 3.8 FIELD QUALITY CONTROL

- A. Field Tests: Owner shall select curtain wall units to be tested as soon as a representative portion of the project has been installed, glazed, perimeter caulked and cured. Conduct tests for air infiltration and water penetration with Manufacturer's representative present. Tests not meeting specified performance requirements and units having deficiencies should be corrected as part of the contract amount.
  1. Testing: Testing shall be performed per AAMA 503 by a qualified independent testing agency. Refer to Division 1 Testing Section for payment of testing and testing requirements.
  2. Air Infiltration Tests: Conduct tests in accordance with ASTM E 783. Allowable air infiltration shall not exceed 1.5 times the amount indicated in the performance requirements or 0.09 cfm/ft<sup>2</sup>, which ever is greater.
  3. Water Infiltration Tests: Conduct tests in accordance with ASTM E 1105. No uncontrolled water leakage is permitted when tested at a static test pressure of two-thirds the specified water penetration pressure but not less than 8 psf.
- B. Manufacturer's Field Services: Upon Owner's request, provide Manufacturer's field service consisting of product use recommendations and periodic site visit for inspection of product installation in accordance with Manufacturer's instructions.

### 3.9 PROTECTION AND CLEANING

- A. Protection: Protect installed product's finish surfaces from damage during construction. Protect steel fire rated glazed curtainwall system from damage from grinding and polishing compounds, plaster, lime, acid, cement, or other harmful contaminants.
  - 1. Cleaning: Repair or replace damaged installed products. Clean installed products in accordance with Manufacturer's instructions prior to owner's acceptance. Remove construction debris from project site and legally dispose of debris.

\*\* END OF SECTION \*\*

## **SECTION 100081 AUTOMATIC ENTRANCES**

### **PART 1 - GENERAL**

#### **1.1 RELATED DOCUMENTS**

- A. Drawings and general provisions of the Contract, including General and Supplementary Conditions and Division 01 Specification Sections, apply to this Section.

#### **1.2 SUMMARY**

##### **A. Section Includes:**

1. **Double slide** unit, with fixed sidelights for main entrances with breakout panels for emergency egress.
2. Provide **Card Access** for **Door 100-2** only. Blackboard Card Reader and Card Reader accessories by Owner.

##### **B. Related Sections:**

1. Division 07 Section "Joint Sealants."
2. Division 08 Sections "Aluminum Curtainwalls"
3. Division 08 Section "Door Hardware."
4. Division 08 Section "Glazing."
5. Division 26 Section for electrical wiring.

#### **1.3 DEFINITIONS**

- A. **Activation Device:** Device that, when actuated, sends an electrical signal to the door operator to open the door.
- B. **Safety Device:** Device that, to avoid injury, prevents a door from opening or closing.

#### **1.4 PERFORMANCE REQUIREMENTS**

- A. **General:** Provide automatic entrance door systems that have the following capabilities based on testing Manufacturer's standard units in assemblies similar to those indicated for this project:
  1. **Operating Temperature Range:** Provide automatic entrance door operators capable of operating between minus 20 deg F and plus 120 deg F.
  2. **Structural Performance:** Provide automatic entrance doors capable of withstanding the effects of gravity loads and the following loads and stresses within limits and under conditions indicated:



- a. Basic Wind Speed: As indicated in miles per hour at 33 feet above grade. Determine wind loads and resulting design pressures applicable to Project according to the following, based on mean roof heights above grade as indicated on Drawings:
  1. Wind Loads: ASCE 7, "Minimum Design Loads for Buildings and Other Structures": Section 6.4.2, "Analytic Procedure."

## 1.5 SUBMITTALS

- A. Submit Letter of Conformance in accordance with Section 013300 with the following supporting data:
  1. Product Data: Include construction details, material descriptions, access control, dimensions of individual components and profiles, and finishes for automatic entrance doors.
  2. Product Certificates: Signed by Manufacturers of automatic entrance doors certifying that products furnished comply with emergency exit door requirements.
  3. Maintenance Data: For door operators and control systems to include in Maintenance Manuals specified in Division 01. Include instructions on how to perform safety tests, and the name, address, and telephone number of nearest authorized service representative.
- B. Shop Drawings: Include plans, elevations, sections, details, hardware mounting heights, and attachments to other Work including curtainwall system.
  1. For installed products indicated to comply with design loads, include structural analysis data signed and sealed by the qualified professional engineer responsible for their preparation.
  2. Wiring Diagrams: Detail wiring for power, signal, and access control systems and differentiate between Manufacturer installed and field installed wiring.

## 1.6 QUALITY ASSURANCE

- A. Installer Qualifications: Manufacturer's authorized representative, with certificate issued by AAADM, who is trained for installation and maintenance of units required for this Project.
- B. Manufacturer Qualifications: A qualified manufacturer with a manufacturing facility certified under ISO 9001.
- C. Manufacturer shall have in place a national service dispatch center providing 24 hours a day, 7 days a week, emergency call back service.
  1. Travel time from Installer's place of business to Project site.
- D. Source Limitations: Obtain automatic entrance doors through one source from a single Manufacturer.
- E. Welding Standards: Comply with AWS D1.2, Structural Welding Code for Aluminum.

- F. ANSI/BHMA Standard: ANSI/BHMA A156.10, "Power Operated Pedestrian Doors."
- G. Electrical Components, Devices and Accessories: Listed and labeled as defined in NFPA 70, Article 100, by a testing agency acceptable to authorities having jurisdiction, and marked for intended use.
- H. Emergency Exit Door Requirements: Comply with requirements of authorities having jurisdiction for automatic entrance doors serving as a required means of egress.

#### 1.7 PROJECT CONDITIONS

- A. Field Measurements: Verify automatic entrance door openings by field measurements before fabrication and indicate measurements on Shop Drawings. Coordinate fabrication schedule with construction progress to avoid delaying the Work.

#### 1.8 COORDINATION

- A. Coordinate size and location of recesses in concrete floors for recessed sliding tracks. Concrete, reinforcement, and formwork requirements are specified in Division 03 Section "Cast-in-Place Concrete."
- B. Electrical System Rough-In: Coordinate layout and installation of automatic entrance door assemblies with connections to power supplies and security access control system.

#### 1.9 WARRANTY

- A. General Warranty: Special warranty specified in this Article shall not deprive Owner of other rights Owner may have under other provisions of the Contract Documents and shall be in addition to, and run concurrent with, other warranties made by Contractor under requirements of the Contract Documents.
- B. Special Warranty: Written warranty, executed by Manufacturer agreeing to repair or replace components of the automatic entrance door system that fail in materials or workmanship within specified warranty period. Failures include, but are not limited to, the following:
  - 1. Lateral deflection of glass lite edges in excess of 1/175 of their length or 3/4 inch, whichever is less.
  - 2. Excessive air leakage.
  - 3. Faulty operation of operators and hardware.
  - 4. Deterioration of metals, metal finishes, and other materials beyond normal weathering.
- C. Warranty Period: **Two years** from date of Substantial Completion.

#### 1.10 MAINTENANCE SERVICE

- A. Maintenance: Beginning at Substantial Completion, provide 12 months' full maintenance by skilled employees of automatic entrance door Installer. Include bi-annual planned and preventive maintenance, repair or replacement of worn or defective components, lubrication,

cleaning, and adjusting as required for proper entrance door operation at rated speed and capacity. Provide parts and supplies as used in the manufacture and installation of original equipment.

1. Perform maintenance, including emergency callback service, during normal working hours.

## PART 2 - PRODUCTS

### 2.1 AUTOMATIC ENTRANCES

#### A. Product and Manufacturer:

1. **Dura-Glide Series 2000** (or equivalent as required by code) bi-parting doors with 8" head, with access control by Stanley Access Technologies, Division of The Stanley Black & Decker, (860-677-2861).
  - a. Exterior Unit: **Dura-Glide Series 2000** bi-parting doors with 8" head with double bevel continuous threshold, set in full bed of silicone sealant.
  - b. Interior Unit: **Dura-Glide Series 2000** bi-parting doors with 8" head, with access control package (Door 100-2).
  - c. 2" Narrow Stile.
  - d. 10" Bottom Rails.
  - e. 4" Muntin (required for access control package).
  - f. 12'-0" Wide x 7'-8" High Unit provides 5'-0" wide x 7'-0" high nominal clear opening.
  - g. 1" Insulated Tinted Tempered Glazing, Refer to Section 088000.
  - h. Jamb mounting within curtainwall opening.
  - i. No Substitutions permitted. The Stanley Dura-Glide Series 2000 is the same door installed in other buildings on campus and the owner wants to maintain the same Maintenance contract for all doors.

### 2.2 AUTOMATIC SLIDING ENTRANCE SYSTEM

#### A. System shall consist of sliding aluminum doors and sidelights, header, operator, cylinders, actuating controls, and directional motion sensors.

1. Exterior with half-beveled threshold complying with ADA and ANSI A117.1.
2. Interior with electronic access control fail secure lock, panic exit device on active door leaves and surface mounted threshold. Provide Manufacturer's standard switch to allow an exit only "night-time" mode to engage the electronic access lock system or control by Owner's Blackboard system.
3. Coordinate access control with Owner's Blackboard access control system and other hardware components specified in Section 087100.
4. Provide **Card Access** for **Door 100-2** only with auto lock package. Blackboard Card Reader and Card Reader accessories by Owner.

5. Provide **emergency key over-ride** to access door 100-2 if Card Reader becomes inactive.
  6. Provide conduit from Doors **100-2** and **200-2** to Telecommunications Room 102 for Owner's Blackboard control wiring for door sensor operation control (open during the day, closed at night with card Access over-ride for Door 100-2 only).
- B. Automatic Sliding Door System: The system shall consist of sliding aluminum doors, sidelights, header, operator, and actuating controls. All components shall be factory assembled in the header, adjusted and tested.
- C. Sliding Aluminum Doors: Provide door units to dimension heights and widths with corresponding glazing as shown on Drawings with standard narrow stile. Door holders shall be provided for all panels to control the doors as they swing in the direction of egress. All door panels shall have security glass stops. All doors shall have intermediate rails. Double slide door systems shall include a two-point lock securing the lead edges of the door stiles together and to the hanger assembly.
- D. Door Operation: Shall be double slide directional operation. In compliance with NFPA 101, the sliding door panels shall allow "breakout" to the full open position to provide instant egress at any point in the door's movement. To allow safe egress, automatic operation shall be discontinued when the sliding panel is in the "breakout" mode. Doors and sidelights shall be sized to prevent pinch points at meeting stiles.
1. Safety Search Circuitry: Shall be provided which will recycle the doors when an object is encountered during the closing cycle. The circuitry shall search for that object on the next closing cycle by reducing the door speed at the position the object was previously encountered and will continue to close in check speed until the doors are fully closed, at which time the doors will reset to normal speed. If the obstruction is encountered again, the doors shall come to a full stop. The door shall remain stopped until the obstruction is removed and an operate signal is given, resetting the door to its normal speed.
  2. The doors shall be provided with a "Fail Secure Electric Carriage Lock" in the header to prevent the doors from sliding in the night mode. This device shall not interfere with emergency breakout function and shall be connected to the Owner's Blackboard access control system.
  3. Coordinate access control with Owner's Blackboard access control system and other hardware components specified in Section 087100.
- E. The doorway activation and safety device shall be:
1. **X-Zone** by Optex
  2. The sensor shall be factory-installed on the header. The interior door sensing device shall be disabled (night mode) by a keyed control switch or the Owner's Blackboard access control system.
- F. Interior Door **100-2** to be activated from exterior during night-mode by remote Blackboard card reader furnished by Owner.
- G. Install automatic entrance system in curtainwall system specified in Section 0844100.
- H. Glazing: Refer to Section 088000. Match adjacent curtainwall and ribbon window systems glazing.

## 2.3 MATERIALS

- A. Aluminum: Alloy and temper recommended by Manufacturer for type of use and finish indicated.
  - 1. Extruded Bars, Rods, Profiles, and Tubes: ASTM B 221.
  - 2. Sheet and Plate: ASTM B 209.
  - 3. Welding Rods and Bare Electrodes: AWS A5.10.
- B. Sealants and Joint Fillers: Refer to Section 079200 Joint Sealants.
- C. Bituminous Paint: Cold applied, asphalt mastic paint complying with SSPC-Paint 12 requirements, except containing no asbestos; formulated for 30-mil thickness per coat.

## 2.4 COMPONENTS

- A. Framing Members: Manufacturer's standard extruded aluminum, minimum 0.125 inch thick and reinforced as required to support imposed loads.
- B. Stile and Rail Doors: Manufacturer's standard 1-3/4-inch-thick glazed extruded aluminum doors. Mechanically fasten corners with reinforcing brackets that are welded or incorporate concealed tie-rods that span full length of top and bottom rails.
- C. Sidelights: Manufacturer's standard 1-3/4-inch-deep sidelights extruded aluminum tubular stile and rail members matching door design.
- D. Headers: Fabricated from extruded aluminum and extending full width of automatic entrance door units to conceal door operators, carrier assemblies, and roller tracks. Provide hinged or removable access panels for service and adjustment of door operators and controls. Secure panels to prevent unauthorized access.
- E. Carrier Assemblies and Overhead Roller Tracks: Manufacturer's standard carrier assembly that allows vertical adjustment; consisting of nylon or delrin covered ball-bearing-center steel wheels operating on a continuous roller track, or ball-bearing-center steel wheels operating on a nylon or delrin covered continuous roller track. Support doors from carrier assembly by cantilever and pivot assembly.
- F. Threshold: Manufacturer's standard threshold members and bottom-guide track system, with stainless-steel ball-bearing-center roller wheels. Set threshold in continuous bed of silicone sealant in compliance with ADA and ANSI A117.1.
- G. Brackets and Reinforcements: Manufacturer's standard high strength aluminum with non-staining, non-ferrous shims for aligning system components.
- H. Fasteners and Accessories: Manufacturer's standard corrosion resistant, non-staining, non-bleeding fasteners and accessories compatible with adjacent materials.
- I. Emergency Breakaway Sign: BHMA A156.10; red background with 1-inch high contrasting letters with the words "IN EMERGENCY PUSH TO OPEN."

## 2.5 FABRICATION

- A. General: Fabricate automatic entrance door system components to designs, sizes, and thicknesses specified and to comply with indicated standards.
- B. Prefabrication: Provide automatic entrance doors as prefabricated assemblies. Complete fabrication, assembly, finishing, hardware application, and other work before shipment to Project site.
  - 1. Do not drill and tap for surface mounted hardware items until time of installation at Project site.
  - 2. Perform fabrication operations, including cutting, fitting, forming, drilling, and grinding of metalwork in manner that prevents damage to exposed finish surfaces. For hardware, perform these operations before applying finishes.
  - 3. Form shapes with sharp profiles, straight and free of defects or deformations, before finishing.
  - 4. Prepare components to receive concealed fasteners and anchor and connection devices.
  - 5. Fabricate components with accurately fitted joints with ends coped or mitered to produce hairline joints free of burrs and distortion.

## 2.6 FINISHES

- A. High Performance Organic Coating.
- B. Fluoropolymer Type: Factory applied two-coat 70% Kynar resin by Arkema or 70% Hylar resin by Solvay Solexis. Fluoropolymer based coating system, Polyvinylidene Fluoride (PVF-2), applied in accordance with Manufacturer's installation procedures and meeting AAMA 2605 specifications and matching curtainwall finishing system.
- C. Color: To be **selected by Architect** from Custom metallic coating color matching curtainwall color with Manufacturer's **15 year** warranty.
- D. Finishes Testing: Apply 0.5% solution NaOH, sodium hydroxide to small area of finished sample area; leave in place for sixty minutes; lightly wipe off NaOH; Do not clean area further. Submit samples with test area noted on each sample.

## PART 3 - EXECUTION

### 3.1 INSPECTION

- A. Automatic entrance door installer to examine areas and conditions where automatic entrances are installed and notify the General Contractor in writing of conditions detrimental to the proper functioning of the entrance and the timely completion of the work. Do not proceed with the work until unsatisfactory conditions have been corrected in a manner acceptable to the installer.

### 3.2 INSTALLATION

- A. Comply with Manufacturer's specifications and recommendations. Set units plumb, level, and true. Fit frame joints to produce hairline joints free of burrs and distortion. Rigidly secure non-movement joints. Seal joints watertight.
  - 1. Where aluminum will contact dissimilar metals, protect against galvanic action by painting contact surfaces with primer or by applying sealant or tape recommended by Manufacturer for this purpose.
  - 2. Where aluminum will contact concrete or masonry, protect against corrosion by painting contact surfaces with bituminous paint.
- B. Sealants:
  - 1. Set framing members, thresholds, bottom guide track system, and flashings in full bed of silicone sealant.
  - 2. Seal perimeter of framing members with sealant. Refer to Section 079200 Joint Sealants.

### 3.3 ADJUST AND CLEAN

- A. After repeated operation of completed installation, readjust door operators and controls for optimum operating condition.
- B. Clean glass and aluminum surfaces promptly after installation.
- C. Advise General Contractor of protective treatment and other precautions required through the remainder of the construction period to ensure that automatic entrances will be without damage or deterioration (other than normal weathering) at the time of acceptance.
- D. Readjust door operators and controls after repeated operation of completed installation equivalent to three days' use by normal traffic (100 to 300 cycles).
- E. Lubricate hardware, operating equipment, and other moving parts.

\*\* END OF SECTION \*\*

## **SECTION 101000 DOOR HARDWARE**

### **PART 1 - GENERAL**

#### **1.1 SUMMARY**

**A. Section includes:**

1. Mechanical door hardware for the following:
  - a. Swinging doors.
  - b. Sliding doors.
  - c. Folding doors.
2. Cylinders for door hardware specified in other Sections.
3. Electrified door hardware.

**B. Related Sections:**

1. Section 10 "Hollow Metal Doors and Frames" for astragals provided as part of labeled fire-rated assemblies and for door silencers provided as part of hollow-metal frames.
2. Section 10 "Access Doors and Frames" for access door hardware, including cylinders.
3. Section 10 "Sectional Doors" for door hardware provided as part of overhead door assemblies.
4. Section 10 "Fire Rated Entrances and Storefronts" for door hardware provided as part of fire-rated door assemblies.
5. Section 10 "Aluminum-Framed Entrances and Storefronts" for installation of entrance door hardware, including cylinders.

#### **1.2 ACTION SUBMITTALS**

**A. Product Data:** For each type of product indicated. Include construction and installation details, material descriptions, dimensions of individual components and profiles, and finishes.

**B. Shop Drawings:** Details of electrified door hardware, indicating the following:

1. Wiring Diagrams: For power, signal, and control wiring and including the following:
  - a. Details of interface of electrified door hardware and building safety and security systems.
  - b. Schematic diagram of systems that interface with electrified door hardware.
  - c. Point-to-point wiring.
  - d. Risers.
  - e. Elevations doors controlled by electrified door hardware.
2. Operation Narrative: Describe the operation of doors controlled by electrified door hardware.



- C. Samples for Initial Selection: For plastic protective trim units in each finish, color, and texture required for each type of trim unit indicated.
- D. Samples for Verification: For exposed door hardware of each type required, in each finish specified, prepared on Samples of size indicated below. Tag Samples with full description for coordination with the door hardware schedule. Submit Samples before, or concurrent with, submission of door hardware schedule.
  - 1. Sample Size: Full-size units or minimum 2-by-4-inch Samples for sheet and 4-inch long Samples for other products.
    - a. Full-size Samples will be returned to Contractor. Units that are acceptable and remain undamaged through submittal, review, and field comparison process may, after final check of operation, be incorporated into the Work, within limitations of keying requirements.
- E. Other Action Submittals:
  - 1. Door Hardware Schedule: Prepared by or under the supervision of Installer, detailing fabrication and assembly of door hardware, as well as installation procedures and diagrams. Coordinate final door hardware schedule with doors, frames, and related work to ensure proper size, thickness, hand, function, and finish of door hardware.
    - a. Submittal Sequence: Submit door hardware schedule concurrent with submissions of Product Data, Samples, and Shop Drawings. Coordinate submission of door hardware schedule with scheduling requirements of other work to facilitate the fabrication of other work that is critical in Project construction schedule.
    - b. Format: Comply with scheduling sequence and vertical format in DHI's "Sequence and Format for the Hardware Schedule." Double space entries, and number and date each page.
    - c. Format: Use same scheduling sequence and format and use same door numbers as in the Contract Documents.
    - d. Content: Include the following information:
      - 1) Identification number, location, hand, fire rating, size, and material of each door and frame.
      - 2) Locations of each door hardware set, cross-referenced to Drawings on floor plans and to door and frame schedule.
      - 3) Complete designations, including name and manufacturer, type, style, function, size, quantity, function, and finish of each door hardware product.
      - 4) Description of electrified door hardware sequences of operation and interfaces with other building control systems.
      - 5) Fastenings and other pertinent information.
      - 6) Explanation of abbreviations, symbols, and codes contained in schedule.
      - 7) Mounting locations for door hardware.
      - 8) List of related door devices specified in other Sections for each door and frame.
  - 2. Keying Schedule: Prepared by or under the supervision of Installer, detailing Owner's final keying instructions for locks. Include schematic keying diagram and index each key set to unique door designations that are coordinated with the Contract Documents.

### 1.3 INFORMATIONAL SUBMITTALS

- A. Qualification Data: For Architectural Hardware Consultant.
- B. Product Certificates: For electrified door hardware, from the manufacturer.
  - 1. Certify that door hardware approved for use on types and sizes of labeled fire-rated doors complies with listed fire-rated door assemblies.
- C. Product Test Reports: For compliance with accessibility requirements, based on evaluation of comprehensive tests performed by manufacturer and witnessed by a qualified testing agency, for door hardware on doors located in accessible routes.
- D. Warranty: Special warranty specified in this Section.

### 1.4 CLOSEOUT SUBMITTALS

- A. Maintenance Data: For each type of door hardware to include in maintenance manuals. Include final hardware schedule.

### 1.5 QUALITY ASSURANCE

- A. Installer Qualifications: Supplier of products and an employer of workers trained and approved by product manufacturers and an Architectural Hardware Consultant who is available during the course of the Work to consult with Contractor, Architect, and Owner about door hardware and keying.
  - 1. Warehousing Facilities: In Project's vicinity.
  - 2. Scheduling Responsibility: Preparation of door hardware and keying schedules.
  - 3. Engineering Responsibility: Preparation of data for electrified door hardware, including Shop Drawings, based on testing and engineering analysis of manufacturer's standard units in assemblies similar to those indicated for this Project.
- B. Architectural Hardware Consultant Qualifications: A person who is experienced in providing consulting services for door hardware installations that are comparable in material, design, and extent to that indicated for this Project and who is currently certified by DHI as follows:
  - 1. For door hardware, an Architectural Hardware Consultant (AHC).
- C. Source Limitations: Obtain each type of door hardware from a single manufacturer.
  - 1. Provide electrified door hardware from same manufacturer as mechanical door hardware, unless otherwise indicated. Manufacturers that perform electrical modifications and that are listed by a testing and inspecting agency acceptable to authorities having jurisdiction are acceptable.
- D. Fire-Rated Door Assemblies: Where fire-rated door assemblies are indicated, provide door hardware rated for use in assemblies complying with NFPA 80 that are listed and labeled by a qualified testing agency, for fire-protection ratings indicated, based on testing at positive pressure according to NFPA 252 or UL 10C, unless otherwise indicated.

- E. Smoke- and Draft-Control Door Assemblies: Where smoke- and draft-control door assemblies are required, provide door hardware that meet requirements of assemblies tested according to UL 1784 and installed in compliance with NFPA 105.
  - 1. Air Leakage Rate: Maximum air leakage of **0.3 cfm/sq. ft.** at the tested pressure differential of **0.3-inch wg** of water.
- F. Electrified Door Hardware: Listed and labeled as defined in NFPA 70, Article 100, by a testing agency acceptable to authorities having jurisdiction.
- G. Means of Egress Doors: Latches do not require more than **15 lbf** to release the latch. Locks do not require use of a key, tool, or special knowledge for operation.
- H. Accessibility Requirements: For door hardware on doors in an accessible route, comply with the U.S. Architectural & Transportation Barriers Compliance Board's ADA-ABA Accessibility Guidelines and ICC/ANSI A117.1.
  - 1. Provide operating devices that do not require tight grasping, pinching, or twisting of the wrist and that operate with a force of not more than **5 lbf**.
  - 2. Comply with the following maximum opening-force requirements:
    - a. Interior, Non-Fire-Rated Hinged Doors: **5 lbf** applied perpendicular to door.
    - b. Sliding or Folding Doors: **5 lbf** applied parallel to door at latch.
    - c. Fire Doors: Minimum opening force allowable by authorities having jurisdiction.
  - 3. Bevel raised thresholds with a slope of not more than 1:2. Provide thresholds not more than **1/2 inch** high.
  - 4. Adjust door closer sweep periods so that, from an open position of 70 degrees, the door will take at least 3 seconds to move to a point **3 inches** from the latch, measured to the leading edge of the door.
- I. Keying Conference: Cylinder cores by Owner.
- J. Preinstallation Conference: Conduct conference at Project site.
  - 1. Review and finalize construction schedule and verify availability of materials, Installer's personnel, equipment, and facilities needed to make progress and avoid delays.
  - 2. Inspect and discuss preparatory work performed by other trades.
  - 3. Inspect and discuss electrical roughing-in for electrified door hardware.
  - 4. Review sequence of operation for each type of electrified door hardware.
  - 5. Review required testing, inspecting, and certifying procedures.

## 1.6 DELIVERY, STORAGE, AND HANDLING

- A. Inventory door hardware on receipt and provide secure lock-up for door hardware delivered to Project site.
- B. Tag each item or package separately with identification coordinated with the final door hardware schedule, and include installation instructions, templates, and necessary fasteners with each item or package.

## 1.7 COORDINATION

- A. Coordinate layout and installation of floor-recessed door hardware with floor construction. Cast anchoring inserts into concrete.
- B. Installation Templates: Distribute for doors, frames, and other work specified to be factory prepared. Check Shop Drawings of other work to confirm that adequate provisions are made for locating and installing door hardware to comply with indicated requirements.
- C. Security: Coordinate installation of door hardware, keying, and access control with Owner's security consultant.
- D. Electrical System Roughing-In: Coordinate layout and installation of electrified door hardware with connections to power supplies and building safety and security systems.
- E. Existing Openings: Where hardware components are scheduled for application to existing construction or where modifications to existing door hardware are required, field verify existing conditions and coordinate installation of door hardware to suit opening conditions and to provide proper door operation.

## 1.8 WARRANTY

- A. Special Warranty: Manufacturer's standard form in which manufacturer agrees to repair or replace components of door hardware that fail in materials or workmanship within specified warranty period.
  - 1. Failures include, but are not limited to, the following:
    - a. Structural failures including excessive deflection, cracking, or breakage.
    - b. Faulty operation of doors and door hardware.
    - c. Deterioration of metals, metal finishes, and other materials beyond normal weathering and use.
  - 2. Warranty Period: Manufacturer standard warranty, unless otherwise indicated.
    - a. Exit Devices: Two years from date of Substantial Completion.
    - b. Manual Closers: 10 years from date of Substantial Completion.

## 1.9 MAINTENANCE SERVICE

- A. Maintenance Tools and Instructions: Furnish a complete set of specialized tools and maintenance instructions for Owner's continued adjustment, maintenance, and removal and replacement of door hardware.
- B. Maintenance Service: Beginning at Substantial Completion, provide six months' full maintenance by skilled employees of door hardware Installer. Include quarterly preventive maintenance, repair or replacement of worn or defective components, lubrication, cleaning, and adjusting as required for proper door and door hardware operation. Provide parts and supplies that are the same as those used in the manufacture and installation of original products.

## PART 2 - PRODUCTS

### 2.1 SCHEDULED DOOR HARDWARE

- A. Provide door hardware for each door as scheduled in Part 3 "Door Hardware Schedule" Article / on Drawings to comply with requirements in this Section.
  - 1. Door Hardware Sets: Provide quantity, item, size, finish or color indicated, and named manufacturers' products or approved products equivalent in function and comparable in quality to named products.
  - 2. Sequence of Operation: Provide electrified door hardware function, sequence of operation, and interface with other building control systems indicated.
- B. Designations: Requirements for design, grade, function, finish, size, and other distinctive qualities of each type of door hardware are indicated in Part 3 "Door Hardware Schedule" Article. Products are identified by using door hardware designations, as follows:
  - 1. Named Manufacturers' Products: Manufacturer and product designation are listed for each door hardware type required for the purpose of establishing minimum requirements. Manufacturers' names are abbreviated in Part 3 "Door Hardware Schedule" Article.
  - 2. References to BHMA Designations: Provide products complying with these designations and requirements for description, quality, and function.

### 2.2 HINGES

- A. Hinges: BHMA A156.1. Provide template-produced hinges for hinges installed on hollow-metal doors and hollow-metal frames.
  - 1. Manufacturers: Subject to compliance with requirements, provide products by one of the following:
    - a. Hager Companies.
    - b. IVES Hardware; an Ingersoll-Rand company.
    - c. McKinney Products Company; an ASSA ABLOY Group company.
    - d. Stanley Commercial Hardware; Div. of The Stanley Works.

### 2.3 CONTINUOUS HINGES

- A. Continuous, Gear-Type Hinges: Extruded-aluminum, pinless, geared hinge leaves joined by a continuous extruded-aluminum channel cap; with concealed, self-lubricating thrust bearings.
  - 1. Manufacturers: Subject to compliance with requirements, provide products by one of the following:
    - a. Roton.
    - b. Pemko.

## 2.4 MECHANICAL LOCKS AND LATCHES

- A. Lock Functions: As indicated in door hardware schedule.
- B. Lock Throw: Comply with testing requirements for length of bolts required for labeled fire doors, and as follows:
  - 1. Bored Locks: Minimum **1/2-inch** latchbolt throw.
- C. Lock Backset: **2-3/4 inches**, unless otherwise indicated.
- D. Lock Trim:
  - 1. Description: As indicated on Hardware Sets.
  - 2. Levers: Wrought.
    - a. Best 9K-3.
  - 3. Operating Device: Lever 15D.
- E. Strikes: Provide manufacturer's standard strike for each lock bolt or latchbolt complying with requirements indicated for applicable lock or latch and with strike box and curved lip extended to protect frame; finished to match lock or latch.
  - 1. Flat-Lip Strikes: For locks with three-piece antifriction latchbolts, as recommended by manufacturer.
- F. Bored Locks: BHMA A156.2; Grade 1; Series 4000.
  - 1. Manufacturers: Subject to compliance with requirements, provide products by the following:
    - a. Best Access Systems; Div. of Stanley Security Solutions, Inc.; **No substitution, Owner Standard**

## 2.5 MANUAL FLUSH BOLTS

- A. Manual Flush Bolts: BHMA A156.16; minimum **3/4-inch** throw; designed for mortising into door edge.
  - 1. Manufacturers: Subject to compliance with requirements, provide products by one of the following:
    - a. Burns Manufacturing Incorporated.
    - b. IVES Hardware; an Ingersoll-Rand company.
    - c. Rockwood.

## 2.6 AUTOMATIC AND SELF-LATCHING FLUSH BOLTS

- A. Automatic and Self-Latching Flush Bolts: BHMA A156.16; minimum 3/4-inch throw; designed for mortising into door edge.
  - 1. Basis-of-Design Product: Subject to compliance with requirements, provide product indicated on schedule or comparable product by one of the following:
    - a. IVES Hardware; an Ingersoll-Rand company.
    - b. Door Control Rockwood.

## 2.7 EXIT DEVICES AND AUXILIARY ITEMS

- A. Exit Devices and Auxiliary Items: BHMA A156.3.
  - 1. Basis-of-Design Product: Subject to compliance with requirements, provide product indicated on schedule:
    - a. Von Duprin; an Ingersoll-Rand company; **No substitution, Owner Standard**

## 2.8 LOCK CYLINDERS

- A. Lock Cylinders: Tumbler type, constructed from brass or bronze, stainless steel, or nickel silver.
  - 1. Basis-of-Design Product: Subject to compliance with requirements, provide product indicated on schedule.
    - a. Best Access Systems; Div. of Stanley Security Solutions, Inc.; **No substitution, Owner Standard**
    - b. Cores by Owner.
- B. Standard Lock Cylinders: Best, no Sub, cores by Owner.

## 2.9 KEYING

- A. By Owner.

## 2.10 OPERATING TRIM

- A. Operating Trim: BHMA A156.6; stainless steel, unless otherwise indicated.
  - 1. Basis-of-Design Product: Subject to compliance with requirements, provide product indicated on schedule or comparable product by one of the following:
    - a. Burns Manufacturing Incorporated.
    - b. IVES Hardware; an Ingersoll-Rand company.
    - c. Rockwood Manufacturing Company.

## 2.11 ACCESSORIES FOR PAIRS OF DOORS

- A. Coordinators: BHMA A156.3; consisting of active-leaf, hold-open lever and inactive-leaf release trigger; fabricated from steel with nylon-coated strike plates; with built-in, adjustable safety release; and with internal override.
- B. Astragals: BHMA A156.22.

## 2.12 SURFACE CLOSERS

- A. Surface Closers: BHMA A156.4; rack-and-pinion hydraulic type with adjustable sweep and latch speeds controlled by key-operated valves and forged-steel main arm. Comply with manufacturer's written recommendations for size of door closers depending on size of door, exposure to weather, and anticipated frequency of use. Provide factory-sized closers, adjustable to meet field conditions and requirements for opening force.
  - 1. Basis-of-Design Product: Subject to compliance with requirements, provide product indicated on schedule:
    - a. LCN Closers; an Ingersoll-Rand company; **No substitution, Owner Standard.**

## 2.13 MECHANICAL STOPS AND HOLDERS

- A. Wall- and Floor-Mounted Stops: BHMA A156.16; polished cast brass base metal.
  - 1. Basis-of-Design Product: Subject to compliance with requirements, provide product indicated on schedule or comparable product by one of the following:
    - a. Burns Manufacturing Incorporated.
    - b. IVES Hardware; an Ingersoll-Rand company.
    - c. Rockwood Manufacturing Company.

## 2.14 OVERHEAD STOPS AND HOLDERS

- A. Overhead Stops and Holders: BHMA A156.8.
  - 1. Basis-of-Design Product: Subject to compliance with requirements, provide product indicated on schedule or comparable product by one of the following:
    - a. Architectural Builders Hardware Mfg., Inc.
    - b. Glynn-Johnson; an Ingersoll-Rand company.
    - c. Rockwood Manufacturing Company.

## 2.15 DOOR GASKETING

- A. Door Gasketing: BHMA A156.22; air leakage not to exceed **0.50 cfm per foot** of crack length for gasketing other than for smoke control, as tested according to ASTM E 283; with resilient or



flexible seal strips that are easily replaceable and readily available from stocks maintained by manufacturer.

1. Basis-of-Design Product: Subject to compliance with requirements, provide product indicated on schedule:
  - a. National Guard Products.
  - b. Pemko Manufacturing Co.; an ASSA ABLOY Group company.
  - c. Reese Enterprises, Inc.

## 2.16 THRESHOLDS

- A. Thresholds: BHMA A156.21; fabricated to full width of opening indicated.

1. Basis-of-Design Product: Subject to compliance with requirements, provide product indicated on schedule:
  - a. National Guard Products.
  - b. Pemko Manufacturing Co.; an ASSA ABLOY Group company.
  - c. Reese Enterprises, Inc.

## 2.17 FABRICATION

- A. Manufacturer's Nameplate: Do not provide products that have manufacturer's name or trade name displayed in a visible location except in conjunction with required fire-rated labels and as otherwise approved by Owner.

1. Manufacturer's identification is permitted on rim of lock cylinders only.

- B. Base Metals: Produce door hardware units of base metal indicated, fabricated by forming method indicated, using manufacturer's standard metal alloy, composition, temper, and hardness. Furnish metals of a quality equal to or greater than that of specified door hardware units and BHMA A156.18.

- C. Fasteners: Provide door hardware manufactured to comply with published templates prepared for machine, wood, and sheet metal screws. Provide screws that comply with commercially recognized industry standards for application intended, except aluminum fasteners are not permitted. Provide Phillips flat-head screws with finished heads to match surface of door hardware, unless otherwise indicated.

1. Concealed Fasteners: For door hardware units that are exposed when door is closed, except for units already specified with concealed fasteners. Do not use through bolts for installation where bolt head or nut on opposite face is exposed unless it is the only means of securely attaching the door hardware. Where through bolts are used on hollow door and frame construction, provide sleeves for each through bolt.
2. Fire-Rated Applications:
  - a. Wood or Machine Screws: For the following:

- 1) Hinges mortised to doors or frames; use threaded-to-the-head wood screws for wood doors and frames.
  - 2) Strike plates to frames.
  - 3) Closers to doors and frames.
- b. Steel Through Bolts: For the following unless door blocking is provided:
- 1) Surface hinges to doors.
  - 2) Closers to doors and frames.
  - 3) Surface-mounted exit devices.
3. Spacers or Sex Bolts: For through bolting of hollow-metal doors.
  4. Fasteners for Wood Doors: Comply with requirements in DHI WDHS.2, "Recommended Fasteners for Wood Doors."
  5. Gasketing Fasteners: Provide noncorrosive fasteners for exterior applications and elsewhere as indicated.

## 2.18 FINISHES

- A. Provide finishes complying with BHMA A156.18 as indicated in door hardware schedule.
- B. Protect mechanical finishes on exposed surfaces from damage by applying a strippable, temporary protective covering before shipping.
- C. Appearance of Finished Work: Variations in appearance of abutting or adjacent pieces are acceptable if they are within one-half of the range of approved Samples. Noticeable variations in the same piece are not acceptable. Variations in appearance of other components are acceptable if they are within the range of approved Samples and are assembled or installed to minimize contrast.

## PART 3 - EXECUTION

### 3.1 EXAMINATION

- A. Examine doors and frames, with Installer present, for compliance with requirements for installation tolerances, labeled fire-rated door assembly construction, wall and floor construction, and other conditions affecting performance.
- B. Examine roughing-in for electrical power systems to verify actual locations of wiring connections before electrified door hardware installation.
- C. Proceed with installation only after unsatisfactory conditions have been corrected.

### 3.2 PREPARATION

- A. Steel Doors and Frames: For surface applied door hardware, drill and tap doors and frames according to ANSI/SDI A250.6.

- B. Wood Doors: Comply with DHI WDHS.5 "Recommended Hardware Reinforcement Locations for Mineral Core Wood Flush Doors."

### 3.3 INSTALLATION

- A. Mounting Heights: Mount door hardware units at heights to comply with the following unless otherwise indicated or required to comply with governing regulations.
  - 1. Standard Steel Doors and Frames: ANSI/SDI A250.8.
- B. Install each door hardware item to comply with manufacturer's written instructions. Where cutting and fitting are required to install door hardware onto or into surfaces that are later to be painted or finished in another way, coordinate removal, storage, and reinstallation of surface protective trim units with finishing. Do not install surface-mounted items until finishes have been completed on substrates involved.
  - 1. Set units level, plumb, and true to line and location. Adjust and reinforce attachment substrates as necessary for proper installation and operation.
  - 2. Drill and countersink units that are not factory prepared for anchorage fasteners. Space fasteners and anchors according to industry standards.
- C. Hinges: Install types and in quantities indicated in door hardware schedule but not fewer than the number recommended by manufacturer for application indicated or one hinge for every **30 inches** of door height, whichever is more stringent, unless other equivalent means of support for door, such as spring hinges or pivots, are provided.
- D. Intermediate Offset Pivots: Where offset pivots are indicated, provide intermediate offset pivots in quantities indicated in door hardware schedule but not fewer than one intermediate offset pivot per door and one additional intermediate offset pivot for every **30 inches** of door height greater than **90 inches**.
- E. Lock Cylinders: Install construction cores to secure building and areas during construction period.
  - 1. Owner to replace construction cores with permanent cores.
- F. Boxed Power Supplies: Locate power supplies as indicated or, if not indicated, above accessible ceilings. Verify location with Owner.
  - 1. Configuration: Provide one power supply for each door opening with electrified door hardware.
- G. Thresholds: Set thresholds for exterior doors and other doors indicated in full bed of sealant complying with requirements specified in Section 24 "Joint Sealants."
- H. Stops: Provide floor stops for doors unless wall or other type stops are indicated in door hardware schedule. Do not mount floor stops where they will impede traffic.
- I. Perimeter Gasketing: Apply to head and jamb, forming seal between door and frame.
- J. Meeting Stile Gasketing: Fasten to meeting stiles, forming seal when doors are closed.

- K. Door Bottoms: Apply to bottom of door, forming seal with threshold when door is closed.

### 3.4 FIELD QUALITY CONTROL

- A. Independent Architectural Hardware Consultant: Owner will engage a qualified independent Architectural Hardware Consultant to perform inspections and to prepare inspection reports.
  - 1. Independent Architectural Hardware Consultant will inspect door hardware and state in each report whether installed work complies with or deviates from requirements, including whether door hardware is properly installed and adjusted.

### 3.5 ADJUSTING

- A. Initial Adjustment: Adjust and check each operating item of door hardware and each door to ensure proper operation or function of every unit. Replace units that cannot be adjusted to operate as intended. Adjust door control devices to compensate for final operation of heating and ventilating equipment and to comply with referenced accessibility requirements.
  - 1. Spring Hinges: Adjust to achieve positive latching when door is allowed to close freely from an open position of 30 degrees.
  - 2. Electric Strikes: Adjust horizontal and vertical alignment of keeper to properly engage lock bolt.
  - 3. Door Closers: Adjust sweep period to comply with accessibility requirements and requirements of authorities having jurisdiction.
- B. Occupancy Adjustment: Approximately six months after date of Substantial Completion, Installer's Architectural Hardware Consultant shall examine and readjust each item of door hardware, including adjusting operating forces, as necessary to ensure function of doors, door hardware, and electrified door hardware.

### 3.6 CLEANING AND PROTECTION

- A. Clean adjacent surfaces soiled by door hardware installation.
- B. Clean operating items as necessary to restore proper function and finish.
- C. Provide final protection and maintain conditions that ensure that door hardware is without damage or deterioration at time of Substantial Completion.

### 3.7 DEMONSTRATION

- A. Engage a factory-authorized service representative to train Owner's maintenance personnel to adjust, operate, and maintain door hardware and door hardware finishes. Refer to Section 30 "Demonstration and Training."

### 3.8 DOOR HARDWARE SCHEDULE

#### A. Hardware Sets: List of manufacturers represented in the hardware sets:

1. Best Lock Corp. (BES)
2. Glynn-Johnson; an Ingersoll-Rand company (GLY)
3. Hager Companies (HAG)
4. LCN Closers; an Ingersoll-Rand company (LCN)
5. Pemko Manufacturing Co.; an ASSA ABLOY Group company (PEM)
6. Rockwood Manufacturing Company (ROC)
7. Roton (ROT)
8. Securitron Magnalock Corporation; an ASSA ABLOY Group company (SEC)
9. Steelcraft Mfg. (STE)
10. Von Duprin; an Ingersoll-Rand company (VON)

\*\* END OF SECTION \*\*

**SECTION 120010**  
**GENERAL PROVISIONS – MECHANICAL**

PART 1 - GENERAL

1.1 WORK INCLUDED

- A. Plumbing Work shall consist of the labor, materials and equipment required for installing the plumbing systems.
- B. Mechanical Work shall include the following Specification Sections and Drawings as outlined:

1. Specifications:

Section 200010	General Provisions – Mechanical
Section 120020	Plumbing Basic Materials
Section 120030	Plumbing Pipe and Pipe Fittings
Section 120040	Plumbing Piping Specialties
Section 120050	Plumbing Specialties
Section 120060	Plumbing Valves
Section 120070	Plumbing Supports and Anchors
Section 120080	Plumbing Insulation
Section 120110	Plumbing Pumps
Section 120120	Sanitary Drainage
Section 120130	Interceptors
Section 120140	Storm Drainage
Section 120150	Water Conditioning System
Section 120160	Water Heaters
Section 120170	Plumbing Fixtures
Section 120180	Special Piping Systems
Section 120190	Fuel Gas Piping and Specialties
Section 120200	Wiring of Plumbing Equipment

- C. Plumbing Work shall be bid as subcontracts in accordance with the bidding requirements.

## 1.2 TERMINOLOGY

- A. Wherever the term, “Contractor” is used in of the Specifications, it shall be interpreted to refer to the Contractor responsible for Work of these Divisions.
- B. Those responsible for Work covered by other portions of the Specification will be indicated by trade, such as Electrical Contractor, General Contractor, etc.

## 1.3 REFERENCE STANDARDS

- A. Portions or all of certain recognized industry or association standards referred to herein as being a requirement of these Specifications shall be considered as binding as though reproduced in full herein. Unless otherwise stated the referenced standard shall be the standard which is current as of the date of issuance of these Specifications. Reference may be made to standards either by full name or for the sake of brevity by letter designation only. The following is a list of the most commonly used standards, but is not all inclusive for these Specifications:

ABMA	American Bearing Manufacturers Association
ADA	Americans with Disabilities Act
AGA	American Gas Association
AMCA	Air Moving and Conditioning Association
ANSI	American National Standards Institute
API	American Petroleum Institute
ARI	American Refrigeration Institute
ASHRAE	American Society of Heating, Refrigerating and Air- Conditioning Engineers
ASME	American Society of Mechanical Engineers
ASSE	American Society of Sanitary Engineers
ASTM	American Society for Testing and Materials
AWS	American Welding Society
AWWA	American Water Works Association
CISPI	Cast Iron Soil Pipe Institute
FM	Factory Mutual Engineering Corporation
I-B-R	Institute of Boiler & Radiator Manufacturers
NEC	National Electrical Code
NEMA	National Electrical Manufacturers Association
NFPA	National Fire Protection Association
OSHA	Occupational Safety and Health Administration

PDI	Plumbing Drainage Institute
SMACNA	Sheet Metal and Air Conditioning Contractors National Association, Inc.
UL	Underwriters Laboratories, Inc.

#### 1.4 PERMITS AND INSPECTIONS

- A. Secure all permits and inspections required by applicable authorities and pay all costs in connection with the Work.
- B. Schedule all inspections required by applicable authorities. Certificates shall be in triplicate and shall be delivered to Owner.
- C. Piping work, specialties, or equipment shall not be concealed or covered until same have been tested and inspected by municipal inspector(s) and observed by Owner. Municipal inspector(s) record of inspections shall be delivered to Owner. Owner and municipal inspector's witnessing of tests shall not relieve Contractor of his responsibility for concealed piping work and specialties, nor for equipment to perform in accordance with Contract Documents.

#### 1.5 CODES AND STANDARDS

- A. Mechanical Work is subject to provisions of the Pennsylvania Uniform Construction Code and has been designed to be in compliance with the Code. Design aspect of the Project shall not be altered regarding building envelope or selection of HVAC, service water heating systems and equipment. Supplemental data published by equipment and system manufacturers to substantiate energy conservation efficiencies throughout the Project shall be furnished at request of Owner.
- B. Mechanical Work shall meet requirements of the National Fire Protection Association, all federal, state, and municipal authority's laws, rules and regulations applicable to the Work and public utilities having jurisdiction over systems specified herein.
- C. Domestic water heater(s) shall be constructed and tested in accordance with recommendations of the National Fire Protection Association, and ASME Code. Equipment shall be stamped with the ASME symbol and National Board number and shall be inspected during construction by an inspector who has been commissioned by the Pennsylvania Department of Labor and Industry to perform such service. Equipment shall be prepared for initial inspection in accordance with Pennsylvania Department of Labor and Industry regulations.
- D. Plumbing Work shall be installed in conformity with applicable portions of the International Plumbing Code, state plumbing codes, local ordinances, and shall be approved as Project progresses by Owner, and local plumbing inspector. Contractor shall certify domestic water systems for compliance with Pennsylvania Plumbing System Lead Ban & Notification Act (No. 33-1989). Nothing in the Specifications shall be construed to permit deviation from requirements of governing code(s).
- E. Installation of all gas piping and gas burning equipment shall conform to recommendations of the American Gas Association, Owner's insurance carrier, and the local utility.



- F. The handling and use of CFC and HCFC refrigerants, whether leaking, venting, recovering, etc., shall be in accordance with US Environmental Protection Agency regulations CFR 58 FR 28660, ASHRAE 15- Safety Code for Mechanical Refrigeration, and ANSI/ASHRAE 34 - Number Designation and Safety Classification of Refrigerants.
- G. Electrical Work shall meet requirements of the National Electrical Code and all federal, state, and municipal authority's laws, rules and regulations applicable to the Work.
- H. Where applicable, materials and equipment shall bear the label of approval of Underwriters Laboratories, Inc.
- I. Reference to codes and standards listed herein shall constitute minimum acceptable requirements. Where Drawings and Specification requirements exceed those of codes listed, Drawings and Specifications shall take precedence for Work of this Project.
- J. If Contractor, during the course of work, observes the existence of hazardous materials in the structure or on the project site, Contractor shall promptly notify Owner. Contractor shall not perform any work pertinent to the hazardous material prior to receipt of special instructions from Owner. "Hazardous materials", for the purpose of this Specification, are defined as asbestos, PCB's, petroleum, radioactive material, or hazardous waste substances.

#### 1.6 SUBSTITUTIONS

- A. Specifications for each piece of equipment and each item of material are written around a product of a specific base manufacturer. This base manufacturer is the basis of design, dimensions and details. The base manufacturer's name and model information are included with the product description as the first named manufacturer under the heading "Acceptable Manufacturer".
- B. "Substitution" manufacturers are defined as any manufacturer other than the one used as the basis of design. "Substitution" manufacturers will be permitted, in accordance with the bidding requirements and where indicated herein.
- C. Manufacturers named in the product description, in addition to the base manufacturer, are "substitution" manufacturers, have been determined to be manufacturers capable of manufacturing products similar to the base manufacturer and these manufacturers are acceptable "substitution" manufacturers to the base manufacturer. Where additional manufacturer's names do not appear with the base manufacturer, the Owner reserves the right to disallow any "substitution" manufacturers. Where the base manufacturer's name is followed by the term "no substitution", no "substitution" manufacturers will be considered.
- D. Naming of specific manufacturers shall not be construed as eliminating products or services of other "substitution" manufacturers having comparable items. Where permitted by these Specifications, and where Bidder desires to use other "substitution" manufacturers, he may submit a request for approval to use the "substitution" manufacturer in accordance with bidding requirements.
- E. Products described in Specifications are intended to set a quality level and ensure a workable system. "Substitution" of manufacturers, including those herein named, may be made only after approval of Owner. Bidder shall assume full responsibility for installation and dimensional

changes required by the use of all “substitution” manufacturer’s products, including revisions to wiring, controls, piping, structural revisions, etc., and all room or space changes as required due to dimension differences of the “substitution” manufacturer product.

- F. Where the Bidding requirements call for submittal for approval of substitutions prior to bids due, all approvals given are for “substitution” manufacturers only, not approval of any particular product. An approved “substitution” manufacturer’s product must comply with all requirements of the specifications for the base manufacturer’s product.

#### 1.7 SHOP DRAWINGS AND PRODUCT DATA

- A. Submit shop drawings and product data for approval to Owner. Shop drawings and product data shall have been reviewed and approved (stamped) by Contractor furnishing the equipment. If evidence of this Contractor’s approval does not appear on submittal data, submittals will be returned without review. Following Owner review, submittals not approved or requiring resubmission shall be corrected and resubmitted until satisfactory. Work indicated on shop drawings and product data shall not be executed until submittals have been approved.
- B. Submittals for equipment and material shall indicate room numbers, drawing identification symbols, product type, capacities, accessories, connection sizes, electrical characteristics, wiring diagrams, and installation instructions. Each shop drawing shall have specified items, accessories and options, as applicable to this Project, clearly marked. Catalog numbers, part numbers, etc. on shop drawings will not be reviewed for correctness, Contractor is responsible for verifying correctness of these and that they relate to the options, accessories, features, etc. marked on the shop drawings. Shop drawings not clearly marked as to only that which will be provided for this Project will not be approved.
- C. In as much as it is not the purpose of the submittal process to assure that the Contractor is meeting all the requirements of the Contract Documents, submittal review by Owner is for conformance with design concept of the Project and general compliance with information given in the construction documents. Approval, corrections and/or comments made as part of the submittal review do not relieve the Contractor of the responsibility from conformance with all requirements of the Contract Documents, applicable codes and laws. Contractor is responsible for dimensions, quantities, and performance requirements to be confirmed and correlated at the job site; for information that pertains solely to the fabrication processes or to techniques of construction; and for all coordination with the Work of all trades. Refer to paragraph entitled “Substitutions” in this section of the specifications.
- D. At the time of each submittal, Contractor shall give Owner specific written notice of such variations, if any, that the Shop Drawing or product submitted may have from the requirements of the Contract Documents, such notice to be in a written communication separate from the submittal; and, in addition, shall cause a specific notation to be made on each Shop Drawing and sample submitted to Owner for review and approval of each such variation. Owner’s review and approval of Shop Drawings or products shall not relieve Contractor from responsibility for any variation from the requirements of the Contract Documents unless Contractor has in writing called the Owner’s attention to each such variation at the time of each submittal and Owner has given written notation thereof incorporated in or

accompanying the Shop Drawing or product approval; nor will any approval by Owner relieve contractor from responsibility for complying with the requirements of this paragraph.

- E. Shop drawing submittals shall be accompanied by a transmittal sheet with the applicable specification section number and the "name" of the item or items being submitted clearly indicated on the transmittal. All "names" on the transmittal shall match exactly the "names" listed in the specifications for the item being submitted.
- F. The name of the supplier, distributor, subcontractor, etc., who will furnish equipment and items to the Contractor shall appear on the shop drawings when submitted. Shop drawing submittals without supplier's, distributors, subcontractors, etc., name will not be reviewed and will be returned without review.
- G. If Owner is required to review any shop drawing or product data submittal more than two times, a Change Order will be issued to the Contractor for a credit due on the Contract Price to recoup Owner's expenses associated with the multiple reviews.
- H. One complete set of approved shop drawings and product data shall be delivered to Owner at completion of Work. Include lists of manufacturer's parts and part numbers.

#### 1.8 COORDINATION – GENERAL

- A. Work shall be governed by requirements set forth in the conditions of the Contract.
- B. Provide all labor, materials, and equipment required by the Contract Documents necessary for completion of the Work of Section 12.
- C. Bidders shall visit the project site to determine actual conditions which will be encountered in completing the work of this project.
- D. Drawings are generally indicative of Work to be installed but may not indicate all bends, fittings, elbows, etc., required to meet conditions. Where items shown on the Drawings, or herein described, are not clearly understood, Bidders shall confer with Owner.
- E. Coordinate Work of Section 12 with that of other trades so that Work will be installed in the most direct manner and so that interference between piping, ducts, conduits, equipment, and architectural or structural features will be avoided. Work installed in an arbitrary manner without regard for Work of other trades or equipment servicing requirements will be rejected in any situation where an undesirable condition or an unfair hardship for other trades, or Owner, results.
- F. Provide sufficient scaffolding and hoist or rig material and equipment into place, or arrange for rigging by others. In any case, rigging or hoisting for Work of Section 12 shall be at the expense of Contractor.
- G. Unless otherwise indicated on the Drawings, provide structural steel members as required for support of equipment and materials furnished under Section 12. Provide all hangers and supports, as specified, detailed, or in accordance with accepted industry standards.

- H. Equipment shall be installed in accordance with equipment manufacturer's installation instructions. Obtain manufacturer's installation instructions prior to roughing-in.
- I. Where equipment is furnished by other trades for installation as Work under Section 12, or where electrical service or utility connection to equipment installed by others is indicated as Work of Section 12, obtain approved shop drawings and installation instructions from the respective contractor prior to roughing-in. Discrepancies between installation instructions and Contract Documents shall be brought to the attention of Owner.
- J. Where equipment is indicated to be furnished as Work of Section 12 for installation by others, or where equipment furnished and installed under Section 12 requires utility connections by others, provide to the respective contractor one copy of an approved shop drawing and installation instructions necessary for execution of his work.
- K. Unless specifically indicated, communication between the mechanical and electrical systems equipment and panels shall be via a dedicated wiring system furnished and installed by the systems installers. These systems shall be separate from all other data communication networks within the building. Contractor may request approval for providing communications on the Owner's building data network. If Owner's written approval is obtained, the system installer shall fully coordinate the necessary data network connections with the Owner, the Owner's technology consultant, and the contractor responsible for installing the building data network system. The systems shall follow the Owner's data network labeling scheme for outlets and jacks, operation protocols, and shall adhere to all network security measures. The system installer shall be responsible for all costs associated with equipment, materials, and labor necessary to furnish and install the communications network including, but not limited to: jacks, wall plates, cables, conduits and boxes, patch panels, patch cords, additional Owner switches and equipment, additional systems equipment, and programming services.

#### 1.9 COORDINATION – NEW CONSTRUCTION

- A. Openings and recesses, including cutting, patching and finishing, necessary for installation of mechanical equipment in new construction will be provided by General Contractor. Coordinate locations, dimensional data, and scheduling of Work with General Contractor.
- B. Where piping is run concealed in concrete masonry unit (block) walls, Contractor shall be responsible for installing his work in cores of block for mason to wall-in as he carries up wall. Coordinate locations and scheduling of Work with General Contractor.
- C. Provide concrete foundation pads for mechanical equipment installed under this Division. Foundations for compressors shall extend through floor slab and be isolated from floor by 1/2 inch thick expansion joint material. Foundations for base mounted pumps and water heaters shall be installed on floor slab. Unless otherwise noted, foundations shall be 4 inches above finished floor and extend a minimum of 2 inches beyond base or bedplate. Inserts and anchor bolts shall be poured into foundation according to equipment manufacturer's instructions. Method of setting, aligning, and anchoring shall be as recommended by equipment manufacturer
- D. General Contractor will furnish and install structural steel members for supporting rooftop equipment. Provide General Contractor with dimensional data required for fabrication of supports.

- E. General Contractor will furnish and install all base flashing for roof mounted equipment. Furnish and install all cap flashing integral to roof mounted equipment and field fabricated. Coordinate with General Contractor's roofer.
- F. Electrical Contractor will wire all motors, resistance coils and controllers, except as noted otherwise in Section 18, Wiring of Mechanical Equipment. Where motor starters and disconnect switches are supplied, and shipped loose with mechanical equipment, they shall be mounted and wired by Electrical Contractor. Verify available power characteristics prior to ordering equipment.

#### 1.10 COORDINATION – EXISTING CONSTRUCTION

- A. Cut all openings required in existing construction for installation of equipment and material. Perform all cutting, patching, and refinishing as required to match surroundings.
- B. Existing Ceilings: Remove existing ceiling tile where required for installation of mechanical Work. Replace ceiling tiles as Work is completed. All damaged or broken ceiling tile caused by Contractor's workers shall be replaced by Contractor at no cost to Owner.
- C. Utility interruptions (including campus heating and chilled water) and tie-ins shall be coordinated with Owner a minimum of 14 days in advance of Work.

#### 1.11 EXCAVATION AND BACKFILL

- A. General Contractor will perform excavation and backfill required for Work of this Division, inside and outside building. Coordinate extent of excavation required with General Contractor.

#### 1.12 PAINTING

- A. Equipment furnished under Section 12 that is pre-painted or pre-finished by manufacturer shall have all nicks, scratches, blemishes, and rust spots cleaned, primed, and refinished prior to final acceptance by Owner.
- B. General Contractor will paint exposed unfinished equipment, piping, ductwork, etc., installed under Section 12.

### 1.13 EXISTING EQUIPMENT

- A. Removal of Existing Equipment and Materials: Items of value as determined by Owner shall be stored on site where directed by Owner. Equipment and material that Owner does not wish to retain shall be legally disposed of offsite. Do not remove any equipment and materials from the site without Owner's approval.
- B. Relocation of Existing Equipment and Materials: Before reinstallation, equipment shall be cleaned and nicks and scratches shall be touched-up. Broken parts shall be brought to the attention of Owner prior to removal or any disassembly.

### 1.14 OPERATION AND MAINTENANCE MANUALS

- A. One (1) complete hard copy and 1 soft copy/electronic set(s) on compact disc(s) of the operating and maintenance manual labeled as described herein shall be submitted to the Owner for approval in as many 3-ring loose leaf binders as required. The copies shall be submitted a minimum of two weeks prior to any instructions and demonstrations to Owner's personnel.
- B. The manuals shall be typewritten and the information shall be arranged in a logical order for use by the Owner in maintaining the equipment and systems installed on the project.
- C. The manuals shall include, but not be limited to the following:
  - 1. Table of contents.
  - 2. Materials list with place of purchase.
  - 3. List of normally replaced items, such as filters, fuses, belts, seals, screens, etc., indicating style, rating, size, etc., and place of purchase.
  - 4. Approved copies of submittals, including component wiring diagrams and BAS wiring piping diagrams of all installed systems indicating all connections, color coding, functions, locations, etc. Approved "As-Noted" submittals shall be corrected to incorporate all approval notes prior to inclusion in the manuals.
  - 5. Installation, servicing, maintenance and operating instructions for all systems and components with place of original purchase, and name, address and phone number of person servicing system.

6. Manufacturer's guarantees and warranties.
7. System and equipment start-up, seasonal changeover, and seasonal shut-down with pre-start checklists and precautions.
8. System and equipment troubleshooting guides.
9. Reference documents which shall include construction drawings list, record set of drawings list, test and balance records.
10. Testing and balancing procedures for each system(s) and system(s) components.
11. Copies of all inspection certificates and approvals from all inspection agencies.
12. Copies of approved testing, adjusting and balancing reports.
13. Copy of all Mechanical Vibration Analysis and Alignment Verification Reports.

#### 1.15 SPARE PARTS AND EQUIPMENT

- A. Furnish to Owner spare parts and equipment at project closeout in accordance with each respective specification section that requires spare parts and equipment.

#### 1.16 FINAL PAYMENT AND ACCEPTANCE

- A. Upon written notice that Work is complete and installed in accordance with intent of Specifications, Mechanical Engineer will make a final inspection with Owner and Contractor. If Mechanical Engineer determines that Work is incomplete, or it contains deficiencies, Contractor shall immediately take such measures as are necessary to complete Work or remedy such deficiencies.
- B. Obligations of Contractor, when making application for final payment, are contained in various sections of the Specifications, Addenda or modifications. These obligations consist of furnishing instruction, record drawings, printed material, tools and devices, clean-up services, credit, certificates, valve listings, start-up test reports.
- C. If documentation required does not accompany final payment application, Mechanical Engineer will not accept Work and will advise that final payment is not recommended. Mechanical Engineer will indicate in writing reasons for refusing to recommend final payment.
- D. If, on basis of Mechanical Engineer's observation of Work during construction and final inspection and Mechanical Engineer's review of final application for payment and accompanying documentation, and if Mechanical Engineer is satisfied that Work has been completed and Contractor has fulfilled all obligations, Mechanical Engineer will indicate in writing his recommendation for final payment. If, through

no fault of Contractor, final completion of Work is significantly delayed and if Mechanical Engineer so confirms, Mechanical Engineer will recommend payment to Contractor for that portion of the Work fully completed and accepted.

- E. Contractor is reminded that his obligation is a continuing one to perform and complete Work in accordance with Contract Documents. Neither recommendation of any progress or final payment, nor issuance of Certificate of Substantial Completion, nor any payment to Contractor by Owner, or any use or occupancy of premises or any part thereof by Owner, will constitute an acceptance of Work.

## PART 2 - PRODUCTS

### 2.1 MATERIALS

- A. All materials and equipment shall be new, without imperfections or blemishes, and shall be protected from the elements prior to installation.
- B. Contractor shall be responsible to verify all furnished materials and equipment are suitable for the service, temperatures, and pressures where they are installed.

## PART 3 - EXECUTION

### 3.1 INSTALLATION

- A. Work shall be installed by mechanics skilled in the trade involved.
- B. All mechanical equipment and materials shall be installed to allow access to and to facilitate service, maintenance, repair, replacement, etc., of components to all equipment furnished and installed under this Division of the specifications, furnished and installed under all other Divisions of the specifications, and, where applicable, Owner furnished and installed and Owner's existing equipment.
- C. Duct work, piping, equipment, etc., shall be installed in such a manner as to preserve access to equipment installed under this project and, where applicable, existing equipment.

### 3.2 CLEANING

- A. Upon completion of Work, remove all dirt, foreign materials, stains, fingerprints, etc., from all parts and equipment.
- B. Remove all construction debris and vacuum interior spaces of all compartmental equipment.
- C. Conduct cleaning and disposal operations to comply with codes, ordinances, regulations and anti-pollution laws.
- D. Work shall be subject to inspection by the Owner.



### 3.3 PROTECTION FROM DUST AND DEBRIS

- A. During patching, painting, ceiling removal and replacement, working on the ceiling or on things above the ceiling, etc., maintain cloths or suitable building paper covers to protect building surfaces. Protective measures (drop cloths, protective covers, etc.) shall be placed and sealed over all furniture and equipment to keep items clean and protected against dirt, dust and debris from entering furniture and equipment that the Owner has not removed.
- B. Upon completion of work each day when building is occupied, remove all temporary covers, drop cloths and debris and vacuum clean all worked-in areas to eliminate carrying of dirt materials and dirt tracking throughout building during times construction is not proceeding.

### 3.4 CONSTRUCTION SEQUENCE

- A. The work shall proceed in accordance with the construction work sequence narrative as issued in Division 01.
- B. Work to be installed through existing building shall be installed at other than normal occupied hours. Coordinate installation times with Owner. Contractor shall be responsible for removing and replacing ceilings for installing items above ceilings in these existing areas. All ceilings removed shall be replaced prior to normal occupied hours.

### 3.5 OPERATING INSTRUCTIONS

- A. Engage qualified instructors to instruct Owner's personnel to adjust, operate, and maintain systems, subsystems, and equipment not part of a system.
- B. Provide instruction at mutually agreed on times. Schedule training with Owner with at least seven days' advance notice.
- C. Instructor shall operate system(s) in order to demonstrate fulfillment of contract requirements and educate Owner's personnel on the following:
  - 1. Basis of system design and operational requirements.
  - 2. Documentation provided in the operating and maintenance manuals.
  - 3. Startup and normal operation instructions.
  - 4. Warning, trouble indications, emergency operation and failure instructions.
  - 5. Adjustments.
  - 6. Inspection and preventative maintenance.
  - 7. Diagnostics and repairs.

### 3.6 WARRANTIES

- A. Where extended warranties beyond the normal one-year warranty are, as specified herein, to be applied to a particular item of equipment or system, furnish to Owner a description of the

warranty along with any required registration and signature of manufacturer's authorized personnel.

- B. Contractor shall be responsible for coordinating with and having the manufacturer administer these warranties for the full extent of time the warranty will be in effect.
- C. Contractor shall be responsible for administering and servicing all extended warranties for the life of each extended warranty at no additional cost to Owner. Owner's responsibility will be for additional costs for parts associated with warranties that are warranted on a pro-rated basis. All labor for administering and servicing the extended warranty, including actual replacement of parts, will be the responsibility of the Contractor for the extended warranty period. All unwarranted shipping and handling costs for parts and equipment will be the responsibility of the Owner.

**\*\*END OF SECTION\*\***

**SECTION 120020  
PLUMBING BASIC MATERIALS**

**PART 1 - GENERAL**

**1.1 WORK INCLUDED**

- A. The Work of this Section shall consist of the labor, materials and equipment required for the installation of basic materials and motors associated with plumbing systems.

**1.2 SUBMITTALS**

- A. Submit for approval in accordance with specified submittal procedures:
1. Access Panels
  2. Fire Stop Sealing System
  3. Equipment Nameplates; including itemized listing of nameplate equipment designations
  4. Motors; submit with each piece of equipment

**PART 2 - PRODUCTS**

**2.1 ACCESS PANELS**

- A. Access Panel Specification No. 1
1. Acceptable Manufacturer: Milcor Style AP for acoustical plaster, Style AT for acoustical tile, or Karp, Krieger, Bilco.
  2. Type: Acoustical ceiling.
  3. Construction: 16 gage galvanized steel frame, 18 gage galvanized steel panel. Recessed to accommodate acoustical ceiling tile. Continuous hinge, steel with stainless steel pin.
  4. Closing Feature: Flush, screw driver operated lock with steel cam.
- B. Access Panel Specification No. 2
1. Acceptable Manufacturer: Milcor Style DW, or Karp, Krieger, Bilco.
  2. Type: Gypsum wallboard.
  3. Construction: 16 gage steel frame, 14 gage steel panel.
  4. Concealed spring hinges. Prime coat finish for field painting.
  5. Closing Feature: Flush, screwdriver operated lock with steel cam.
- C. Access Panel Specification No. 3
1. Acceptable Manufacturer: Milcor, or Karp.

2. Type: Fire rated.
3. Construction: 16 gage steel frame, 20 gage steel panel.
4. Continuous hinge with stainless steel pin. Automatic panel closer. Factory attached masonry anchors.
5. Rating: UL listed 1 1/2 hour (B label), temperature rise 30 minutes, 250 degrees F. maximum.
6. Closing Feature: Self latching lock, direct action knurled knob, interior latch release mechanism.

D. Access Panel Specification No. 4

1. Acceptable Manufacturer: Milcor Style M, or Karp, Krieger, Bilco.
2. Type: Masonry, tile, or wood.
3. Construction: 16 gage frame, 14 gage panel. Concealed spring hinges. Prime coat finish for field painting or stainless steel, satin finish, as required.
4. Closing Feature: Flush screwdriver operated lock with steel cam.

E. Access Panel Specification No. 5

1. Acceptable Manufacturer: Milcor Style K, or Karp, Krieger, Bilco.
2. Type: Plastered surfaces.
3. Construction: 16 gage frame, 14 gage panel. Concealed spring hinges. Prime coat finish for field painting.
4. Closing Feature: Flush, screwdriver operated lock with steel cam.

## 2.2 FIRE STOP SEALING SYSTEM

- A. Acceptable Manufacturer: Nelson Firestop Products CLK Silicone Sealant, or 3M Fire Protection Products, RectorSeal, Specified Technologies (STI), Tremco.
- B. Materials: Single component, ready-to-use, water-resistant, flexible elastomeric silicone sealant. Non-sag/gunnable grade for penetrations in vertical surfaces, self-leveling grade for floor applications.
- C. Compliance: Fire endurance tested per ASTM E-814 (UL 1479). In addition to compliance as a fire stop, the cured sealing system shall not permit smoke or water penetration.

## 2.3 EQUIPMENT NAMEPLATES

- A. Laminated phenolic, two outer layers of white phenolic and an inner layer of black with engraving depth to the inner layer.
- B. Nameplates for non-powered equipment and equipment connected to normal power circuits shall be laminated phenolic with two outer layers of black phenolic and an inner layer of white with engraving depth to the inner layer. Nameplates for equipment connected to normal-emergency power circuits shall have red outer layers.

- C. Nameplate and lettering suitably sized for their location, but not less than 1/4 inch high letters.

## 2.4 MOTORS

- A. Acceptable Manufacturers: Baldor, Reliance, Toshiba, US Motor (Emerson), or Weg. No substitutions.
- B. Motor Characteristics:
  - 1. Duty: Continuous duty at ambient temperature of 40 degrees C and at an altitude of 3300 feet above sea level.
  - 2. Capacity and Torque Characteristics: Sufficient to start, accelerate, and operate connected loads at designated speeds, at installed altitude and environment, with indicated operating sequence, and without exceeding nameplate ratings or considering service factor. Horsepower rating shall not be less than size indicated on Drawings.
- C. Three Phase Motors:
  - 1. Description: NEMA MG 1, Design B, medium induction motor.
  - 2. Efficiency: Premium efficiency, as defined by NEMA MG 1.
  - 3. Voltage: As indicated on Drawings.
  - 4. Service Factor: 1.15.
  - 5. Insulation: NEMA Class F.
  - 6. Sound Power Levels: Conform to NEMA MG 1.
  - 7. Bearings: Grease lubricated anti-friction ball bearings with housings equipped with plugged provision for re-lubrication, rated for minimum AFBMA 9, L-10 life of 200,000 hours.
  - 8. Thermal Protection: Internal, automatically reset.
  - 9. Motors Used with Variable Frequency Drives:
    - a. Windings: Copper magnet wire with moisture-resistant varnish, designed and tested to resist transient spikes, high frequencies, and short time rise pulses produced by pulse-width modulated inverters.
    - b. Premium-Efficient Motors: Class B temperature rise; Class F insulation.
    - c. Inverter-Duty Motors: Class F temperature rise; Class H insulation.
    - d. Shaft grounding ring.
- D. Single Phase Motors:
  - 1. Larger Than 1/20 HP: One of the following, to suit starting torque and requirements of specific motor applications:
    - a. Permanent-split capacitor.
    - b. Split phase.
    - c. Capacitor start, inductor run.
    - d. Capacitor start, capacitor run.
  - 2. Motors 1/20 HP and Smaller: Shaded-pole type. Multispeed Motors: Variable-torque, permanent-split-capacitor type.

3. Voltage: As indicated on Drawings.
  4. Bearings: Prelubricated, antifriction ball bearings or sleeve bearings.
- E. Thermal Protection: Internal, automatically reset.

## PART 3 - EXECUTION

### 3.1 INSTALLATION

#### A. Access Panels

1. Furnish and install access panels in ceilings and walls for service and repair access to concealed equipment, including, but not limited to:
  - a. Valves: hand operated and automatic
  - b. Backflow preventers
  - c. Gages and thermometers
  - d. Water hammer arresters
  - e. Pressure regulating/reducing valves
2. Minimum Size: 18 inches by 18 inches. Where restrictions will not permit minimum size, verify access panel size with Architect.
3. Provide access panels in accordance with the following schedule:

ACCESS PANEL SCHEDULE	
Application	Access Panel Spec. No.
Acoustical tile or acoustical plaster finishes	1
Gypsum board (dry wall) finishes	2
Fire rated walls	3
Masonry, tile, or wood finishes	4
Plastered finishes	5

4. Access panel location(s) that are indicated on drawings are of a specific concern. However, Contractor shall be responsible to furnish and install access panels as required.

#### B. Sleeves and Plates

1. Furnish and install sleeves for all pipes passing through floors, walls, partitions, slabs, grade beams and foundations.
2. Layout, size, and locate sleeves such that they be set and installed prior to pouring concrete, or when masonry is being constructed. In event sleeves must be placed after floor, wall, grade beam, etc., has been constructed, submit in writing to and obtain

approval from Owner on location, quantity and proposed method of core drilling and installing.

3. Core drilled openings above grade in solid concrete need not be sleeved but must be clean and neat without cracking or spalling.
4. Sleeves shall be standard weight galvanized steel pipe having square cut ends with anchoring lugs welded on. Horizontal sleeves through walls, grade beams, foundations, and partitions shall be flush with finished wall faces. Vertical sleeves through floors shall extend 2 inches above finished floor and be flush with finished ceiling or underside of floor construction. Sleeves in pits or below grade shall be painted or coated with one coat of coal tar pitch paint.
5. Size sleeves such that internal diameter is 2 pipe sizes or a minimum of 2 inches larger than outside diameter of bare pipe for uninsulated lines and 2 inches larger than outside diameter of insulation and jacket for insulated lines. Center pipes in sleeves.
6. For pipes passing through floors, slabs, walls, grade beams, or foundations at or below grade and in pits, the annular space between outside of pipe or insulation and inside of sleeve shall be packed with a pliable, non-hardening waterproof mastic sealer or a cement base quick set repair mortar.
7. For pipes passing through walls and floors above grade and with no fire or smoke rating, the annular space between outside of pipe or insulation and inside of sleeve or concrete shall be packed tight with batt type fiberglass insulation.
8. For pipes passing through walls and floors above grade with smoke or fire rating of one hour or more, the annular space between outside of pipe and insulation and inside of sleeve or concrete shall be sealed with fire stop sealing system.

#### C. Fire Stop Sealing System

1. All floor and interior wall penetrations with smoke or fire rating of one hour or more shall be sealed. Refer to architectural drawings for locations of fire rated floors and walls.
2. Prepare penetration and install sealing material in accordance with the manufacturer's recommendations.
3. Through penetration fire stop sealing systems shall be identified on both sides with permanently mounted, preprinted vinyl labels which include the following information:
  - a. The words "Warning: Through Penetration Firestop System – Do Not Disturb" or similar phrase.
  - b. Manufacturer's brand name, product type or catalog number
  - c. Testing agency designation and rating
  - d. Installer's Name
  - e. Installation Date

#### D. Equipment Nameplates

1. Furnish and install a full complement of nameplates for all items of mechanical equipment installed as Work of this Division, including water heaters, pumps, mixing valves and control panels.
2. Install nameplates parallel to equipment lines.
3. Unless noted, nameplates shall be attached with sheet metal screws or epoxy cement. Epoxy cement shall not be used equipment installed outdoors.

4. Coordinate with Owner for nameplate designations. Submit a complete itemized listing of nameplate equipment designations for approval.
5. Prior to fabricating nameplates, complete and submit a listing for all installed central plumbing system equipment. Nameplates shall include the following information:
  - a. Unit #
  - b. Date unit put in service
  - c. Contractor
  - d. Manufacturer
  - e. Model #
  - f. Serial #

**\*\*END OF SECTION\*\***



**SECTION 120030  
PLUMBING PIPE AND PIPE FITTINGS**

**PART 1 - GENERAL**

**1.1 WORK INCLUDED**

- A. The Work of this Section shall consist of the labor, materials and equipment required for the installation of plumbing piping and pipe fittings.

**PART 2 - PRODUCTS**

**2.1 PIPE AND PIPE FITTINGS**

- A. Pipe shall conform to the materials specified herein, and shall be installed for piping systems as scheduled in Part 3 – Execution, of this Section.

**2.2 TYPE L COPPER PIPE SPECIFICATION NO. 1**

- A. Design Pressure: 150 psig.
- B. Maximum Design Temperature: 200 degrees F.
- C. Sizes 2 inches and smaller:
  - 1. Tubing: Type L hard drawn seamless copper tube, ASTM B88.
  - 2. Joints: Solder type with 95-5 solder, or press coupled.
  - 3. Fittings: Wrought copper solder joint, ANSI B16.22 or cast bronze solder joint, ANSI B16.18, or with EPDM O-rings, ASME B16.18 or ASME B16.22.
- D. Sizes 2 1/2 inches and larger:
  - 1. Tubing: Type L hard drawn seamless copper tube, ASTM B88.
  - 2. Joints: Flanged and solder type with 95-5 solder, or press coupled.
  - 3. Fittings: Wrought copper solder joint, ANSI B16.22 or cast bronze solder joint, ANSI B16.18, or wrought copper press coupled joint. ANSI B16.22.
  - 4. Flanges: 150 lb. class cast bronze, ANSI B16.24.

**2.3 TYPE K COPPER UNDERGROUND PRESSURE PIPE SPECIFICATION NO. 2**

- A. Design Pressure: 150 psig.
- B. Maximum Design Temperature: 150 degrees F.

- C. Sizes 2 inches and smaller:
  - 1. Tubing: Type K hard drawn seamless copper tube, ASTM B88.
  - 2. Joints: Solder type with 95-5 solder.
  - 3. Fittings: Wrought copper solder joint, ANSI B16.22 or cast bronze solder joint, ANSI B16.18.
- D. Sizes 2 1/2 inches and 3 inches:
  - 1. Tubing: Type K hard drawn seamless copper tube, ASTM B88.
  - 2. Joints: Flanged and solder type with 95-5 solder.
  - 3. Fittings: Wrought copper solder joint, ANSI B16.22 or cast bronze solder joint, ANSI B16.18.
  - 4. Flanges: 150 lb. class cast bronze, ANSI B16.24.
- E. Pipes penetrating building floors on grade or building walls or pit walls below grade shall be ductile iron. Refer to Ductile Iron Pressure Pipe Specification No. 6.

#### 2.4 SERVICE WEIGHT CAST IRON PIPE SPECIFICATION NO. 3

- A. Approvals: Cast iron soil pipe and pipe fittings shall be marked with the collective trademark of the Cast Iron Soil Pipe Institute (CISPI) and shall be listed by NSF International.
- B. Design Pressure: Gravity.
- C. Maximum Design Temperature: 180 degrees F.
- D. All Pipe Sizes:
  - 1. Pipe & Fittings
    - a. Below Grade: Service weight cast iron soil pipe, tar coated inside and outside, ASTM A74.
    - b. Above Grade: Hubless cast iron soil pipe, tar coated inside and outside, CISPI Standard 301, ASTM A888.
  - 2. Joints
    - a. Below Grade: Hub and spigot, compression.
    - b. Above Grade: Hubless.
  - 3. Adapters: Transitions from cast iron soil pipe to another pipe material shall be made with Fernco Joint Sealer Company PVC Donut adapters, or approved equal. Hubless transitions shall be made with an approved, shielded coupling for the purpose and material.
- E. Vent Flashing: By General Contractor.

#### 2.5 TYPE DWV COPPER PIPE SPECIFICATION NO. 4

- A. Design Pressure: Gravity.

- B. Maximum Design Temperature: 180 degrees F.
- C. Sizes 1-1/4 inches through 4 inches:
  - 1. Pipe: Type DWV hard temper seamless copper drainage tube, ASTM B306.
  - 2. Joints: Solder. ASTM B32, Grade 50B.
  - 3. Fittings: Cast bronze solder joint drainage type, ANSI B16.23 or wrought copper solder joint drainage type, ANSI B16.29.
- D. Vent Flashing: By General Contractor.

#### 2.6 SCHEDULE 40 GALVANIZED STEEL PIPE SPECIFICATION NO. 5

- A. Design Pressure: Gravity.
- B. All Sizes:
  - 1. Pipe: Schedule 40 galvanized steel, threaded and coupled, ASTM A53.
  - 2. Joints: Threaded, ASTM B16.3.
  - 3. Fittings: Galvanized cast iron screwed drainage type, ANSI B16.4.
- C. Vent Flashing: By General Contractor.

#### 2.7 SCHEDULE 40 BLACK STEEL PIPE SPECIFICATION NO. 8

- A. Design Pressure: 150 psig.
- B. Maximum Design Temperature: 350 degrees F.
- C. Sizes 2-1/2 inches and smaller:
  - 1. Pipe: Schedule 40 black steel, threaded and coupled, ASTM A53.
  - 2. Joints: Threaded. (Exception: All gas piping installed in steel conduits; all gas conduit and conduit vent pipe; all black steel pipe installations below ground; shall be continuous butt weld joints.)
  - 3. Fittings: 150 lb (S) 300 lb (WOG) black malleable iron.
  - 4. Unions: 250 lb (S) 500 lb (WOG) black malleable iron, ground joint with brass seat.
- D. Sizes 2-1/2 inches and larger:
  - 1. Pipe: Schedule 40 black steel, beveled ends, ASTM A53.
  - 2. Joints: Butt welded and flanged.
  - 3. Fittings: Schedule 40 seamless steel, butt weld type, ASTM A234.
  - 4. Flanges: 150 lb forged steel, welding neck or slip on, ASTM A181 Class 60.
- E. All piping installed below ground shall have factory applied coal tar coating. Below ground joints shall have a field applied coal tar coating.

2.8 REINFORCED CONCRETE PIPE SPECIFICATION NO. 9

- A. Design Pressure: Gravity.
- B. Maximum Design Temperature: 160 degrees F.
- C. Round Pipe, Sizes 10 inches and larger:
  - 1. Pipe: Reinforced concrete, Class III with tongue and groove ends, ASTM C76.
  - 2. Joints: Flexible, water tight rubber gaskets, ASTM C443.
  - 3. Adapters: Transitions from another material to concrete pipe shall be made with Fernco Joint Sealer Company PVC Donut adapters.
- D. Elliptical (Oval) Culverts, All Pipe Sizes:
  - 1. Pipe: Reinforced concrete, HE Class III with tongue and groove ends, ASTM C507.
  - 2. Joints: Mortar, tongue and groove.
  - 3. Socket, factory threaded or flanged solvent cement.

2.9 SCHEDULE 40 PVC PIPE SPECIFICATION NO. 13

- A. Design Pressure: Gravity.
- B. Maximum Design Temperature: 150 degrees F. at continuous flow.
- C. All Pipe Sizes:
  - 1. Schedule 40, polyvinyl chloride (PVC), ASTM D2665 with NSF seal.
  - 2. Fittings: Schedule 40, polyvinyl chloride, DWV pattern, ASTM D2665 with NSF seal.
- D. Sizes: 2 inches and smaller:
  - 1. Joints: Socket or factory threaded solvent cement ASTM D2564.
- E. Sizes: 2-1/2 inches or larger:
  - 1. Joints: Socket or flanged solvent cement ASTM D2564.
- F. Vent Flashing: By General Contractor.

2.10 SCHEDULE 40 ABS PIPE SPECIFICATION NO. 16

- A. Design Pressure: Gravity.
- B. Maximum Design Temperature: 180 degrees F. at continuous flow.
- C. All Pipe Sizes:
  - 1. Pipe: Schedule 40, acrylonitrile butadiene styrene (ABS), ASTM D2661 with NSF seal.
  - 2. Fittings: Socket or factory threaded solvent cement, ASTM D2235.

D. Vent Flashing: By General Contractor.

2.11 ACID RESISTENT POLYPROPYLENE PIPE SPECIFICATION NO. 20

A. Design Pressure: Gravity.

B. Maximum Design Temperature: 150 degrees F.

C. All Pipe Sizes:

1. Pipe & Fittings: Schedule 40, Type II acid resistant polypropylene compound with no reprocess or reclaim materials added, ASTM. Fittings shall conform in dimensions to normally accepted plumbing fittings and shall meet all requirements of local plumbing codes.
2. Joints: Joints shall be socket welded using only electric socket welding tools.

PART 3 - EXECUTION

3.1 APPLICATION

A. Piping systems shall be installed in accordance with the following pipe schedule(s).

PIPE SCHEDULE*		
Service	Application	Pipe Spec. No.
Dom. Cold Water	Above Grade	1
	Below Grade	2
Dom. Hot Water	Above Grade	1
Dom. Hot Water Recirculating	Above Grade	1
Dom. Water Pipe Connections to Water Heaters	All	1
Sanitary	Above Grade	3, 4, 13 or 16
	Below Grade, within bldg.	3, 13 or 16
Sanitary Vent	Above Grade	3, 4, 5, 13 or 16
	Below Grade	3, 13 or 16
Storm Drainage	Above Grade	3, 13 or 16
	Below Grade, within bldg.	3, 9, 13, 16
Propane Gas	Above Grade	8
	Below Grade, within bldg.	8
Compressed Air	All	8
Vacuum	All	1

---

PIPE SCHEDULE\*

---

Service	Application	Pipe Spec. No.
Acid Waste	All	20

\* Where plastic piping is used, it shall be the Contractor's responsibility to ensure compatibility of the installed piping system with the building's HVAC system. Where plenum rated materials are required by any federal, state, or municipal authority's construction codes, plastic piping shall be covered in its entirety by an approved fire retardant insulating material. Fire retardant insulating systems shall be certified to meet ASTM E-84 and UL 723 standards for flame spread and smoke generation. Fire retardant insulating systems shall be approved by the Authority Having Jurisdiction prior to installation.

### 3.2 INSTALLATION

- A. Contractor shall carefully follow the Drawings in laying out and installing his work and he shall not deviate therefrom, except for structural or interior finish interferences.
- B. All pipe and fittings shall be carefully inspected for defects in workmanship prior to installation. Any item found unsuitable, cracked, or otherwise defective shall be rejected and removed from the jobsite. All pipe and fittings shall have factory applied markings, stampings, or nameplates with sufficient data for identification to determine their conformance with specified requirements.
- C. Plastic piping shall be installed in strict accordance with pipe manufacturer's recommendations and in accordance with the recommendations of the Plastic Pipe Institute. Protect plastic piping from damage by adjacent sharp surfaces with rubber or plastic grommets or sleeves.
- D. During construction all openings in piping shall be kept closed except when actual work is being performed on that item. Closures shall be plugs, caps, blind flanges, or other items specifically intended for this purpose. Exercise all necessary care to prevent foreign objects from entering material.
- E. Run pipe lines straight and true, parallel to building lines with a minimum use of offsets and couplings. Use full and double lengths of pipe wherever possible.
- F. Changes in direction shall be made only with pipe bends or fittings. Changes in size shall be made with fittings only. All fittings shall be of the long radius type, unless otherwise specified. Changes in direction on drainage pipe systems shall be made with wye fittings, combination wye and eighth bends, or one eighth bends. Offset in soil or waste pipes will not be permitted where avoidable. Offsets shall be made with 45 degree bends or similar fittings.
- G. Provide flanges or unions at all final connections to equipment and valves to facilitate dismantling.
- H. Unless otherwise indicated, install all piping to pumps and other equipment at line size with reduction in size being made only at inlet to pump or equipment connection.

- I. All pipe shall be cut to exact measurement, and installed without springing or forcing. Particular care shall be taken to avoid creating, even temporarily, undue loads, forces or strains on valves, equipment or building elements with piping connections or piping supports.
- J. Install bell and spigot pipe, such that spigot ends point in direction of flow.
- K. Unless otherwise indicated, branch take offs shall be from top of mains or headers at either a 45 degree or 90 degree angle from the horizontal plane for air and gas lines, and from top, bottom or side for liquids.
- L. Pipe joints connecting dissimilar metals shall be insulating, dielectric connections. Copper tubing shall be protected from electrolysis at contact points with ferrous metals, including temporary methods of support, by use of insulating, non conductive spacers such as rubber, fiberglass or an approved equal. Pipe hangers for bare copper tubing shall be copper plated.

### 3.3 PIPE JOINTS

- A. Heavy-duty No-hub Coupling: Heavy duty coupling shall conform to the requirements of ASTM C1540 with AISI 304 stainless steel bi-directional corrugated shield with AISI 304 stainless steel clamps and screw housing. Gasket shall conform to ASTM C564.
- B. Compression Joints, Hub and Spigot Soil Pipe: Joint shall be one piece double seal compression type gasket made specifically for joining cast iron soil pipe. The gasket shall be neoprene material, permitting joint to flex as much as 5 degrees without loss of seal. Gasket shall be extra heavy conforming to ASTM C564 and ASTM C1563. Installation shall be in accordance with manufacturer's published instructions.
- C. Press Coupled Joints: Copper press fittings in copper domestic water pipe, types L and K, shall be a NSF-61, ASME B16.22 and ASTM B88 approved external compression system. System shall be rated to hold 200 PSI working pressure with a temperature range from 0 degrees Fahrenheit to 250 degrees Fahrenheit. System may be rated for installation on wet or dry piping for sizes 1/2 inch to 4 inch diameter. Fittings shall be properly cleaned prior in accordance with manufacturer's recommendations prior to installation.
- D. Solder Joints: Make up joints with 95 percent tin and 5 percent antimony (95-5) solder conforming to ASTM B32 Solder Metal, Grade 95TA. Cut copper tubing so ends are perfectly square and remove all burrs inside and outside. Thoroughly clean sockets of fittings and ends of tubing to remove all oxide, dirt, and grease just prior to soldering. Apply flux evenly, but sparingly, over all surfaces to be joined. Heat joints uniformly to proper soldering temperature so solder will flow to all mated surfaces. Wipe excess solder, leaving a uniform fillet around cup of fitting. Flux shall be non acid type. Remove composition discs from solder end valves during soldering.
- E. Welded Joints: The welding of all pipe joints, both as to procedures and qualification of welders, shall be in accordance with Section IX, ASME Boiler & Pressure Vessel Code, unless mandatory local codes take precedence. Ends of pipe and fittings to be joined by butt welding shall be beveled, cleaned to bare metal and internal diameters aligned before tack welding.
- F. Threaded Joints: Pipe screw threads shall conform to ANSI B16.3, Malleable Iron Threaded Fittings or ASTM B687, Brass, Copper, and Chromium Plated Pipe Nipples. Ream pipe ends

and remove all burrs and chips formed in cutting and threading. Protect plated pipe and brass valve bodies from wrench marks when making up joint. Apply thread lubricant to male threads only.

- G. Flanged Joints: Steel pipe flanges shall conform to ANSI B16.5, Steel Pipe Flanges and Flanged Fittings. Cast iron pipe flanges shall conform to ANSI B16.1, Cast Iron Flanges and Flanged Fittings. Steel flanges shall be raised face except when bolted to flat cast iron flange. Bolting for services up to 500 degrees F. shall be ASTM A307, Grade B with square head bolts and heavy hexagonal nuts conforming to ANSI B18.2.1, Square and Hex Bolts and B18.2.2, Square and Hex Nuts. Set flange bolts beyond finger tightness with an indicating torque wrench to insure equal tension in all bolts. Tighten bolts such that those 180 degrees apart or directly opposite are torqued in sequence. Gaskets for flat face flanges shall conform to requirements for Group I Gaskets in ANSI B16.5. Unless otherwise specified, gaskets shall be 3/32 inch thick.
- H. Solvent Cement Joints: Socket joints in PVC, ABS, etc., pipe shall be made by using a manufacturer's recommended solvent cement suitable for respective pipe (CPVC, PVC, ABS, Schedule 40, Schedule 80) and conforming to ASTM D2564. Follow manufacturer's instructions for handling and cementing procedures. Wipe off excess cement fillet around socket. Do not move pipe while cement is setting.
- I. Factory Threaded Solvent Cement Joints: Factory threaded solvent cement joints for plastic pressure piping systems shall be made in accordance with manufacturer's recommendations. The threads should be lubricated with a non-hardening pipe dope or wrapped with Teflon tape.

**\*\*END OF SECTION\*\***



**SECTION 120040  
PLUMBING PIPING SPECIALTIES**

**PART 1 - GENERAL**

**1.1 WORK INCLUDED**

- A. The Work of this Section shall consist of the labor, materials, and equipment required for the installation of plumbing piping specialties.

**1.2 SUBMITTALS**

- A. Submit for approval in accordance with specified submittal procedures:
  - 1. Branch Connections
  - 2. Pipe & Valve Identification
  - 3. Expansion Compensators, Pipe Guides, Anchors
  - 4. Dielectric Connections
  - 5. Thermometers
  - 6. Pressure Gages

**PART 2 - PRODUCTS**

**2.1 BRANCH CONNECTIONS**

- A. Branch connections shall be made with standard tee of the type required for the service unless otherwise specified or detailed.
- B. At Contractor's option, branch connections from headers and mains may be cut into black steel pipe using forged weld on fittings. Weld on fittings shall conform to chemical and physical requirements of ASTM A 234 and design and installation requirements of ANSI B31.1.
- C. Weld on fittings shall have a pressure rating equal to, or greater than, the maximum working pressure of the pipe system where they are installed.
  - 1. Acceptable Manufacturer: Allied Piping Products Co. Branchlets (Shaped nipples), or Bonney Forge Weldolet & Thredolet
- D. At Contractor's option, branch connections from headers and mains may be cut into copper to be using mechanically extracted collars. Collars shall be formed in a continuous operation consisting of drilling a pilot hole and drawing out the tube surface to form a collar having a height of not less than three times the thickness of the tube wall. Main pipe shall be vacuumed to clear all debris during collar forming procedure. Branch pipe shall be notched to conform with the inner curve of the run tube and dimpled to insure penetration of the branch pipe into the

collar at sufficient depth for brazing. All joints shall be brazed. Mechanical formed branch collars shall be UL listed.

1. Acceptable Manufacturer: T Drill, Division of Serlachius.

## 2.2 ESCUTCHEON PLATES

- A. Plates shall be installed on all pipes and conduit passing through floors, walls, partitions, etc., in exposed areas.
- B. Plates installed on pipe passing through core drilled openings in solid concrete without sleeves shall be solid ring, cast iron with one set screw for sizes up to 4 inches and two set screws for sizes up to 8 inches.
- C. Plates installed on pipe and conduit passing through openings with sleeves shall be solid ring, cast iron.

## 2.3 PIPE AND VALVE IDENTIFICATION

- A. Acceptable Manufacturer: W. H. Brady Company, or Seton Nameplate Corp., Brimar Industries.
- B. Shutoff valves and control equipment shall be marked by means of a brass or plastic disc minimum of 1 inch in diameter fastened to valve wheel or stem by brass wire or chain. Each disc shall have a legibly marked identification number. A typewritten chart listing all valve tags, location, and service shall be included in the operating and maintenance manual. The valve chart numbering sequence shall be approved by Owner. Existing valve tags on valves to be replaced shall be reinstalled on the new valve. Existing valve tags on valves to be removed shall be turned over to Owner.
- C. All piping installed as Work of this Division shall be identified by legend and flow arrow. Identification system shall conform to ANSI A13.1. Identification markers shall use ANSI standard background colors and text size. Markers shall be attached to pipe by wrapping with color coded banding tape. Markers shall be located as follows:
  1. Near each valve and control device.
  2. Near each branch connection, excluding short takeoffs for fixtures and terminal units. Where flow pattern is not obvious, mark each pipe at branch.
  3. Near penetrations through walls, floors, ceilings, and non-accessible enclosures.
  4. At access doors, manhole, and similar access points that permit view of concealed piping.
  5. Near major equipment items and other points of origination and termination.
  6. Spaced at maximum intervals of 25 feet along each run.

## 2.4 EXPANSION COMPENSATORS, GUIDES, ANCHORS

- A. Expansion Compensator Type EXC-2
  1. Acceptable Manufacturer: Flexonics, or Keflex, Metraflex, Hyspan.

2. Compensators shall be suitable for absorbing expansion and contraction in copper pipe 3 inches and smaller. Compensators shall be constructed with two ply phosphor bronze or stainless steel bellows, brass shroud, and threaded end fittings.
  3. Units shall have internal guides, internal anti torque device, positioning clip, 150 psi maximum working pressure up to 1 inch pipe size, 125 psi over 1 inch pipe size, 400 degrees F maximum operating temperature, and 2 inch stroke.
  4. degrees F. (welded end fitting, 800 degrees F. flanged end fitting). Stroke as listed on Drawings.
- B. Provide dielectric flanges where compensators are used with copper pipe.
- C. Pipe Guides
1. Acceptable Manufacturer: Flexonics Pipe Alignment Guides, or Keflex, Metraflex, Hyspan.
  2. Pipe guides shall be installed as scheduled on the Drawings in accordance with manufacturer's recommendations. Guides shall consist of steel segmented spider, sized to the OD of the pipe, and free to move axially in a segmented steel cylinder. Guides shall be securely attached to the building structure.
- D. Pipe Anchors
1. Anchors shall be installed in accordance with pipe guide manufacturer's and expansion compensator manufacturer's recommendations. Anchors shall securely attach the piping system to the building structure.

## 2.5 DIELECTRIC CONNECTIONS

- A. Pipe joints connecting dissimilar metals shall be insulating, dielectric connections. Dielectric connections shall also be furnished for joining similar metals in order to isolate cathodically protected pipelines from adjoining pipe sections. Such joints, including dielectric material, shall be rated to withstand the temperature, pressure, and other characteristics of the service for which it is to be used, including testing pressure.
- B. Screwed joints shall be made with insulating unions.
1. Acceptable Manufacturer: Watts, or Stockham Valves & Fittings.
- C. Flanged joints shall be made up with insulating gaskets, bolt sleeves, and washers.
1. Acceptable Manufacturer: Watts.

## 2.6 THERMOMETERS

- A. Acceptable Manufacturer: Trerice, or Weiss, Miljoco.
- B. Thermometers shall be installed where indicated on the Drawings. Thermometers shall be 9 inch scale with 9 3/4 inch cast aluminum case, acrylic window, liquid-filled, and separable socket. Socket shall be installed in path of water flow. Indication of operating temperature shall

read in middle third of scale. Thermometers installed 7 feet or more above floor shall be adjustable type.

## 2.7 PRESSURE GAGES

- A. Acceptable Manufacturer: Trerice, or Weiss, Miljoco.
- B. Pressure gages shall be installed where indicated on the Drawings. Gage shall have a 4 inch diameter dial with indication of operating pressure read in middle third of scale. Gages shall have phosphor bronze tube, bronze brushed movement, cast aluminum case with black finish, and an accuracy of 1 percent of scale range. Pressure gage shall be provided with pigtail and stop, and shall be installed vertically.

## PART 3 - EXECUTION

### 3.1 INSTALLATION

- A. Contractor shall carefully follow the Drawings in laying out and installing his work. He shall not deviate therefrom, except for structural or interior finish interferences.
- B. All equipment and accessories shall be carefully inspected for defects in workmanship prior to installation. Any item found unsuitable, cracked, or otherwise defective shall be rejected and removed from the jobsite. All equipment shall have factory applied markings, stampings, or nameplates with sufficient data for identification to determine their conformance with specified requirements.
- C. Piping specialties shall be installed in accordance with the equipment manufacturer's recommendations.
- D. During construction all openings in equipment shall be kept closed except when actual work is being performed on that item. Closures shall be plugs, caps, blind flanges, or other items specifically intended for this purpose. Exercise all necessary care to prevent foreign objects from entering material.
- E. Provide flanges or unions at all final connections to equipment to facilitate dismantling.
- F. Unless otherwise indicated, branch take offs shall be from top of mains or headers at either a 45 degree or 90 degree angle from the horizontal plane for air, or gas lines and from top, bottom, or side for liquids.
- G. Pipe joints connecting dissimilar metals shall be insulating dielectric connections. Copper tubing shall be protected from electrolysis at contact points with ferrous metals, including temporary methods of support, by use of insulating non-conductive spacers such as rubber, fiberglass, or an approved equal. Pipe hangers for bare copper tubing shall be copper plated.

**\*\*END OF SECTION\*\***

**SECTION 120050  
PLUMBING SPECIALTIES**

**PART 1 - GENERAL**

**1.1 WORK INCLUDED**

- A. The Work of this Section shall consist of the labor, materials and equipment required for installation of the domestic water systems and associated specialties.
- B. Domestic water shall be distributed to all fixtures and equipment. Mains shall be valved and capped for extension and use by Owner, where indicated.
- C. Domestic water supply shall be extended from existing system.

**1.2 SUBMITTALS**

- A. Submit for approval in accordance with specified submittal procedures:
  - 1. Hydrants
  - 2. Hose Bibbs
  - 3. Water Hammer Arresters
  - 4. Thermostatic Mixing Valves
  - 5. Temperature-Pressure Relief Valves
  - 6. Vacuum Breakers
- B. Submit written verification of testing procedures specified herein.

**PART 2 - PRODUCTS**

**2.1 HYDRANTS**

- A. Wall Hydrant WH-1
  - 1. Acceptable Manufacturer: J. R. Smith, or Zurn, Wade, Josam.
  - 2. Type: Non-freeze.
  - 3. Materials
    - a. Body: Bronze.
    - b. Face: Polished bronze, nickel bronze, or brass.
    - c. Casing: Bronze or brass.
  - 4. Key: T-handle.
  - 5. Inlet: 3/4 inch IPS.
  - 6. Vacuum Breaker: Integral feature.

## 2.2 HOSE BIBBS

### A. Hose Bibbs

1. Acceptable Manufacturer: Chicago, or T & S Brass.
2. Type: Exterior.
3. Finish: Polished chrome plated.
4. Outlet: 3/4 inch hose thread.
5. Inlet: 3/4 inch flanged female IPS.
6. Handle: Removable tee handle/shield cap.
7. Vacuum Breaker: Integral.

## 2.3 WATER HAMMER ARRESTERS

### A. Water Hammer Arrester for Standard Plumbing Fixtures

1. Acceptable Manufacturer: J. R. Smith Hydrotrol, or Zurn, Wade, Watts, Josam.
2. Type: Bellows surrounded by hydraulic fluid and nitrogen or argon pressurized chamber or pre-pressurized tank with butyl diaphragm that separates air and water or free turning brass piston with O-ring seals that separates air and water.
3. Material: Stainless steel or steel tank with polypropylene liner surge chamber, or barrel fabricated of type K hard drawn copper.

## 2.4 THERMOSTATIC MIXING VALVE (TMV-1)

- A. Acceptable Manufacturer: Powers Hydroguard, or Symmons.
- B. Features: Hi/Lo single valve, tamper proof temperature adjustment control, union inlets, combination strainer-check-stops, built-in shutoff in the event of hot or cold water supply failure, or thermostatic element failure.
- C. Thermostatic mixing valve(s) shall be installed in accordance with manufacturer's piping installation diagram(s).

## 2.5 THERMOSTATIC MIXING VALVE (TMV-2 & 3) (EMERGENCY EYEWASH AND SHOWER)

- A. Acceptable Manufacturer: Bradley S19-2100 & S19-2200 or HAWS.
- B. Features: Tamperproof temperature adjustment control, union inlets, combination strainer-check-stops, built-in cold water bypass, built-in shut-off in the event of hot or cold water supply failure, or thermostatic element failure, and built-in dial thermometer.

- C. Components: Factory assembled thermostatic mixing valve, high temperature limit valve, bypass valve, and outlet temperature gage.
- D. Thermostatic mixing valve(s) shall be installed in accordance with manufacturer's piping installation diagram(s).

## 2.6 THERMOSTATIC MIXING VALVE (TMV-4 THRU TMV-7)

- A. Acceptable Manufacturer: Symmons or Powers.
- B. Features: Tamperproof temperature adjustment control, union inlets, combination strainer-check stops, built-in shutoff in the event of hot or cold water supply failure, or thermostatic element failure.
- C. Thermostatic mixing valve(s) shall be installed in accordance with manufacturer's piping installation diagram(s).

## 2.7 TEMPERATURE-PRESSURE RELIEF VALVE

- A. Acceptable Manufacturer: Watts.
- B. Construction: Bronze body. ASME rated, AGA certified. Non-mechanical seat-to-disc alignment.

## 2.8 VACUUM BREAKER

- A. Acceptable Manufacturer: Watts.
- B. Type: Anti-siphon with bronze body and internal trim, plane brass finish, with full size orifice.
- C. Working Pressure: 125 psi.

# PART 3 - EXECUTION

## 3.1 INSTALLATION

- A. Install plumbing specialties in accordance with equipment manufacturer's recommendations. Submit manufacturer's printed installation instructions, operating and maintenance data, and wiring diagrams for all electric powered equipment at completion of Work.
- B. Connections to fixtures and equipment shall be according to manufacturer's recommendations. Piping runs shall be made in a manner to insure easy and even flow, eliminate air pockets, and to permit drainage and venting. Provide 6 inch (minimum) separation between hot and cold water piping.
- C. Mains and principle branches shall be valved for isolation and shall have drain valves installed at low points for system draining.

- D. Rough-in and make final connections to equipment furnished by Owner. Verify all locations for roughing-in with equipment supplier prior to start of Work.
- E. Furnish and install proper plastic-to-copper adapters for all plumbing fixture supplies.
- F. Domestic hot and cold water piping systems shall be disinfected prior to use. Method to be used shall be that method prescribed by local codes, or, if method is not prescribed by local code, the International Plumbing Code (latest edition) method should be followed. For plastic water piping systems verify with plastic pipe manufacturer that disinfection solution to be used will not harm piping system.
- G. Thermostatic mixing valves shall be installed in accordance with manufacturer's piping installation diagram(s) and referenced details.

### 3.2 TESTING AND BALANCING

- A. Water Lines: Test water lines in accordance with local codes. If method is not prescribed by local codes, the International Plumbing Code (latest edition) method shall be followed.
- B. Valves: Test valve bonnets for tightness. Test-operate valves at least one time from closed-to-open-to-closed positions while valve is under pressure. Test automatic valves for proper operation at settings indicated. Test pressure relief valves minimum of three times.
- C. Other Tests: Test all piping specialties for proper operation.

\*\*END OF SECTION\*\*



**SECTION 120060  
PLUMBING VALVES**

**PART 1 - GENERAL**

**1.1 WORK INCLUDED**

- A. The Work of this Section shall consist of the labor, materials and equipment required for the installation of plumbing valves.

**1.2 SUBMITTALS**

- A. Submit for approval in accordance with specified submittal procedures:
  - 1. Valves

**PART 2 - PRODUCTS**

**2.1 VALVES**

- A. Furnish and install valves as specified herein and as scheduled in Part 3 - Execution, of this Section. Insofar as possible all valves shall be of a single manufacturer.
- B. Packings, gaskets, discs, seats, diaphragms, lubricants, etc., shall conform to recommendations of the valve manufacturer for the intended service.
- C. If space permits, install valves with stems horizontal or extending vertically upward unless specifically shown otherwise. Valves shall be installed in accessible locations for operation as well as for removal, repair, or replacement.
- D. Valves installed in Insulated Piping: With stem or neck extensions of sufficient length to accommodate insulation thickness and the following features:
  - 1. Ball Valves: With extended operating handle of non-thermal-conductive material, and protective sleeve that allows operation of valve without breaking the vapor seal or disturbing insulation.
- E. Provide Owner with one operating wrench for every ten (10) valves of each type (but not less than 2 wrenches) not equipped with handwheels or levers.
- F. Valves shall conform to the following schedules:

---

BALL VALVE SPECIFICATIONS

---

Type	Size	Press. psig	Description	Acceptable Manufacturer
BA-2	thru 2"	150S 400WOG	NSF/AWWA approved for potable water; Threaded ends; Bronze, two piece body; Manually operated; Chrome plated bronze ball; Teflon seats	Apollo Milwaukee Nibco
BA-5	2" thru 8"	200WC 200 degrees F.	NSF approved for potable water; Flanged ends; Epoxy coated A126 Class B iron body; Teflon-fused solid ball; Full port; 100 percent lead free	American Valve
BA-7	1/2" & 3/4"	5 psig	Threaded ends; Bronze body; Two piece body, full port chrome plated brass ball	Apollo CB-10 Nibco GB
BA-8	1" thru 2"	5 psig	Threaded ends; Bronze body; Full port chrome plated brass ball	Nibco T-FP600 Jomar JMT-100

---

CHECK VALVE SPECIFICATIONS

---

Type	Size	Press. psig	Description	Acceptable Manufacturer
CK-2	thru 2"	125S 200WOG	Soldered ends; Bronze body; Renewable bronze disc swing type	Crane Nibco Hammond Anvil International Milwaukee
CK-3	2-1/2" thru 12"	125S 200WOG	Flanged ends; Iron body; Bronze trim; Bronze disc swing type	Crane Nibco Hammond Anvil International Milwaukee

PLUG VALVE SPECIFICATIONS				
Type	Size	Press. psig	Description	Acceptable Manufacturer
PL-1	thru 2"	200WOG	Threaded ends; Cast iron body; Lubricated plug; Wrench operated	Walworth
PL-2	2-1/2" thru 10"	200WOG	Flanged ends; Cast iron body; Lubricated plug; 4" & under: wrench operated; over 4": worm gear operated	Walworth

### PART 3 - EXECUTION

#### 3.1 APPLICATION

- A. Valves shall be installed in accordance with the following valve schedule:

VALVE SCHEDULE			
Piping System	Valve Service		
	Shut-off	Balancing	Check
Domestic Water, Copper: Cold, Hot, Hot Recirc., Make-up	BA-2, BA-5	n/a	CK-2, CK-3
Propane Gas	BA-7, BA-8, PL-1, PL-2	n/a	n/a
Compressed Air	BA-2	n/a	n/a

#### 3.2 INSTALLATION

- A. Contractor shall carefully follow the Drawings in laying out and installing his work and he shall not deviate therefrom, except for structural or interior finish interferences.
- B. All valves shall be carefully inspected for defects in workmanship prior to installation. Any item found unsuitable, cracked, or otherwise defective shall be rejected and removed from the job site. All valves shall have factory applied markings, stampings, or nameplates with sufficient data for identification to determine their conformance with specified requirements.

- C. Provide flanges or unions at all final connections to valves to facilitate dismantling.
- D. Unless otherwise indicated, install all shutoff valves to pumps and other equipment at line size with reduction in size being made only at inlet to pump or other equipment.

**\*\*END OF SECTION\*\***

**SECTION 120070  
PLUMBING SUPPORTS AND ANCHORS**

**PART 1 - GENERAL**

**1.1 WORK INCLUDED**

- A. The Work of this Section shall consist of the labor, materials and equipment required for the installation of plumbing supporting devices.

**PART 2 - PRODUCTS**

**2.1 HANGERS – INSULATED PIPING**

- A. Acceptable Manufacturer: Anvil International, or Penn Pipe Hanger.
- B. Hangers used with insulated piping shall be sized to accommodate the pipe, and insulation and shall have a support shield to prevent the hanger from compressing the insulation. Hanger shall be clevis type with rod and two nuts or bolt and nut.

**2.2 HANGERS – UNINSULATED PIPING**

- A. Acceptable Manufacturer: Anvil International, or Penn Pipe Hanger.
- B. Hangers for uninsulated ferrous pipe shall be clevis type with rod and two nuts or bolt and nut. Hangers for uninsulated copper pipe shall be clevis type with bolt and nut and shall be copper plated.

**2.3 INSERTS – POURED CONCRETE**

- A. Acceptable Manufacturer: Anvil International, or Penn Pipe Hanger.
- B. Inserts shall have cast malleable iron body and nut with galvanized finish.

**2.4 INSERTS – PRECAST OR CURED CONCRETE**

- A. Acceptable Manufacturer: Hilti HSL.
- B. A high integrity, torque controlled anchor for heavy duty fastenings. Loads shall not exceed manufacturer's recommended weight.

**2.5 BEAM CLAMPS**

- A. For pipe sizes of 3 inches and smaller:

1. Acceptable Manufacturer: Anvil International, or Penn Pipe Hanger.
2. Clamps for attachment to I beams and/or steel joists shall be malleable iron C clamp with hardened steel cup and point set screw and locknut.

B. For pipe sizes of 4 inches and larger:

1. Acceptable Manufacturer: Anvil International.
2. Clamps for attachment to I beams and/or steel joists shall be adjustable type with malleable iron jaw, steel tie rod, nuts, and washer.

## 2.6 PIPE RISER CLAMPS

A. Acceptable Manufacturer: Anvil International, or Penn Pipe Hanger.

B. Pipe riser clamps for both insulated and uninsulated vertical pipe risers shall be 2 piece clamp complete with 2 bolts and 2 nuts, sized for the outside diameter of the bare pipe to be supported. Clamp shall be carbon steel construction with galvanized finish for ferrous pipe and copper plated for copper pipe.

## PART 3 - EXECUTION

### 3.1 INSTALLATION

- A. The requirements of the applicable Sections of ANSI B31, Pressure Piping shall be considered as minimum requirements governing fabrication, installation, and support of piping systems except where more specific or stringent requirements are stated herein.
- B. All piping and piping connected equipment, including valves, traps, and other specialties and accessories shall be supported in a manner that will not result in excessive stress, deflection, swaying, sagging or vibration in the piping or in the building structure either during erection, cleaning, testing, or normal operation of the systems. Piping shall not be so restrained, however, as to cause it to snake or buckle between supports or anchors, or to prevent proper movement due to expansion and contraction. Piping shall be supported at equipment and valves such that they can be disconnected and removed without further supporting the piping. Piping shall not introduce any strains or distortion to the connected equipment.
- C. Hangers, riser clamps, and supports shall be installed complete, including locknuts, clamps, rods, bolts, couplings, swivels, inserts, and required accessory items. Hangers for horizontal piping shall have adequate means of vertical adjustment for proper alignment of pipe, and shall be provided with locknuts. All hangers, riser clamps, and supports in direct contact with copper piping shall be copper plated or plastic coated.
- D. Maximum spacing of supports for horizontal piping, except plastic piping, shall be as listed below. Provide hanger rods in diameters recommended by hanger manufacturer.

<u>Pipe Size</u>	<u>Uninsulated Steel</u>	<u>Insulated Steel</u>	<u>Copper Tubing</u>	<u>Cast Iron</u>
1/2"	7'	7'	5'	-
3/4"	7'	7'	5'	-
1"	7'	7'	5'	-
1-1/4"	7'	7'	6'	-
1-1/2"	9'	9'	8'	-
2"	10'	10'	8'	5'
2-1/2"	11'	10'	9'	5'
3"	12'	10'	10'	5'
4"	12'	10'	10'	5'
5"	12'	10'	10'	5'
6"	12'	10'	10'	5'
8"	12'	10'	10'	5'

- E. Maximum spacing of supports for horizontal plastic sanitary drainage and vent piping shall be as listed below. Provide hanger rods in diameters recommended by hanger manufacturer.

<u>Pipe Size</u>	<u>Sanitary Drainage</u>	<u>Sanitary Vent</u>
1-1/2"	3'	4'
2"	3'	4'
3"	3-1/2'	4'
4"	4'	4'
6"	4'	4'
8"	4'	4'
10"	4'	4'

- F. Maximum spacing of supports for horizontal plastic rainwater conductors shall be as listed below. Provide hanger rods in diameters recommended by hanger manufacturer.

<u>Pipe Size</u>	<u>Storm Drainage</u>
2"	4'
4"	4'
6"	4'
8"	4'
10"	4'

- G. Provide additional supports where pipe changes direction, adjacent to flanged valves and at equipment connections and heavy fittings. Provide at least one hanger adjacent to each joint in cast iron soil pipe and grooved end steel pipe with mechanical couplings. Support vertical pipe with riser clamps installed below hubs, couplings or lugs welded to the pipe.
- H. Refer to Section 12, Special Piping Systems for maximum spacing of supports for acid waste piping.

- I. Inserts for supports in precast concrete slabs shall be drilled with rotary electric drill.
- J. Lag screws shall be used to attach hangers to wood construction.
- K. Beam clamps shall be used to attach hanger rods to structural steel.

**\*\*END OF SECTION\*\***



**SECTION 120080  
PLUMBING INSULATION**

**PART 1 - GENERAL**

**1.1 WORK INCLUDED**

- A. The Work of this Section shall consist of the labor, materials and equipment required for insulating plumbing piping and equipment.

**1.2 SUBMITTALS**

- A. Submit for approval in accordance with specified submittal procedures:
  - 1. Insulation Materials, including application thicknesses
  - 2. Sealants, Adhesives, Coatings

**PART 2 - PRODUCTS**

**2.1 FIBERGLASS PIPE INSULATION SPECIFICATION NO. 1**

- A. Acceptable Manufacturer: Johns Manville Micro Lok AP T Plus, or Owens Corning Fiberglas SSL II/ASJ.
- B. Material: Fiberglass pipe insulation with all purpose vapor barrier jacket for indoor installations.
- C. Properties
  - 1. Maximum K Factor: 0.23 at 75 degrees F. mean.
  - 2. Temperature Range: 0 degrees F. to 850 degrees F.
  - 3. Fire Hazard: FHC 25/50 per ASTM E 84 and UL 723.
  - 4. For use on pipe sizes 1/2 inch to 12 inches
- D. Seams and Joints: Self-sealing (pressure sensitive) lap seams and matching butt strips.
- E. Fittings
  - 1. Fiberglass batt inserts with premolded PVC jacket:
    - a. Acceptable Manufacturer: Johns Manville Zeston 2000 PVC, or Foster Speed Line, Proto.
    - b. Properties: 0.28 max. K at 75 degrees F. mean, 0 degrees F. to 450 degrees F. temperature range, FHC 25/50 fire hazard per ASTM E 84.
  - 2. Fitting insulation shall be same thickness as adjacent insulation.

2.2 FLEXIBLE ELASTOMERIC PIPE INSULATION SPECIFICATION NO. 2

- A. Acceptable Manufacturer: Armacell AP Armaflex w/520 BLV Adhesive, or Rubatex.
- B. Material: Flexible elastomeric thermal pipe insulation, black in color.
- C. Properties
  - 1. Maximum K Factor: 0.27 at 75 degrees F.
  - 2. Compliance: ASTM E84, 25 flame/50 smoke.
  - 3. Temperature Range: Minus 70 degrees F. to 220 degrees F.
  - 4. For use on pipe sizes: 3/8 inch to 6 inch.
- D. Fittings, Joints: Mitered cut, same thickness as adjacent insulation.
- E. Adhesive: Toluene free, low VOC.

2.3 FLEXIBLE ELASTOMERIC SHEET/ROLL INSULATION SPECIFICATION NO. 4

- A. Acceptable Manufacturer: Armacell AP Armaflex w/520 Adhesive, or Rubatex.
- B. Material: Exterior flexible elastomeric thermal sheet or roll insulation.
- C. Properties
  - 1. Maximum K Factor: 0.27 at 75 degrees F. mean.
  - 2. Compliance: ASTM E84, 25 flame/50 smoke.
  - 3. Temperature Rating: Minus 70 degrees F. to 220 degrees F.

PART 3 - EXECUTION

3.1 APPLICATION

- A. Insulation shall be installed in accordance with the following insulation schedule(s). (Where more than one insulation type is scheduled, Contractor shall have the option of choosing from types listed.)

PIPE INSULATION SCHEDULE

Service	Temp. Range Deg. F	Insul. Spec. No.	Minimum Pipe Insulation Thickness				
			Runouts		Mains		
			to 2"	to 1"	1-1/4" to 2"	2-1/2" to 4"	5" & larger
Dom Cold	30-60	1	1/2	1/2	1/2	1/2	1/2
Water		2	1/2	1/2	1/2	1/2	1/2

PIPE INSULATION SCHEDULE

Service	Temp. Range Deg. F	Insul. Spec. No.	Minimum Pipe Insulation Thickness				
			Runouts		Mains		
			to 2"	to 1"	1-1/4" to 2"	2-1/2" to 4"	5" & larger
Dom. Hot Water	100-139	1	1	1	1	1	1
	140-169	2	1	1	1	1-1/2	1-1/2
		2	1	1	1	1-1/2	1-1/2
Dom. Hot Water	100-139	1	1	1	1	1	1
		2	1	1	1	1	1
Recirculating Dom Make-up Water	50-65	1	1/2	1/2	1/2	1/2	1/2
		2	1/2	1/2	1/2	1/2	1/2
Horiz. Rain Water	---	1	N/A	N/A	N/A	1/2	1/2
		2	N/A	N/A	N/A	1/2	1/2

EQUIPMENT INSULATION SCHEDULE

Equipment	Insulation Spec. No.	Thickness, Inches
Roof Drain Body	4	1/2

3.2 INSTALLATION

A. General

1. Surface areas of all pipe to be insulated shall be clean and dry. Insulation shall not be installed until all tests and inspections of the specific system(s) are complete.
2. All pipe insulation shall be continuous through wall and ceiling/floor penetrations except where specific sealing requirements are specified, i.e. fire rated separations.
3. Insulate all components in piping systems, including valve bodies, hangers, guides, anchors, and pump housings. Do not insulate expansion compensators in hot water systems. Maintain access to all servicing points and nameplate data.
4. Insulation on all cold surfaces shall provide a continuous unbroken vapor seal.
5. Provide shields at all pipe hangers where protection saddles are not installed on pipes. Shields shall be galvanized sheet metal, formed to fit insulated pipe outside diameter, and shall extend up to the pipe centerline. Shield lengths shall be as follows:

Pipe Sizes, Inches	Shield Length, Inches
1-1/2 to 2-1/2	10
3 to 6	12

Pipe Sizes, Inches	Shield Length, Inches
8 to 10	16
12 and over	22

6. Insulation installed on plastic piping shall be installed with provisions for pipe expansion, without effect on insulation.
7. Adhesives, mastics, sealers, and coatings shall be applied at manufacturer's required ambient conditions and recommended minimum coverage.

B. Fiberglass Pipe Insulation

1. All piping shall be cleaned of debris prior to installation of insulation and components. Joints shall be butted firmly together. Longitudinal laps and butt strips shall be securely fastened as recommended by the manufacturer.
2. Fittings, insulated with fiberglass blanket and PVC jacket shall be installed in accordance with insulation manufacturer's instructions. All butt joints between longitudinal pipe insulation and fittings shall be taped.

C. Flexible Elastomeric Thermal Pipe and Sheet Insulation

1. Insulation shall be installed neatly with oversized pipe insulation and sheet insulation being used for fittings and valves. For outdoor installations, completely wrap insulation surface with glass fiber mesh and fully adhere/lag glass mesh to insulation with one coat of insulation adhesive. Inspect for bonding of glass mesh to insulation surfaces before applying specified weatherproof finish. Consult insulation manufacturer's recommendations for coatings and sealants.

\*\*END OF SECTION\*\*

## **SECTION 120110 PLUMBING PUMPS**

### **PART 1 - GENERAL**

#### **1.1 WORK INCLUDED**

- A. The Work of this Section shall consist of the labor, materials and equipment required for the installation of plumbing pumps.

#### **1.2 RELATED SECTIONS**

- A. Section 12, Plumbing Basic Materials: Equipment nameplates and motors.
- B. Section 1, Building Automation System: Controls.

#### **1.3 SUBMITTALS**

- A. Submit for approval in accordance with specified submittal procedures:
  - 1. Pumps

### **PART 2 - PRODUCTS**

#### **2.1 INLINE CIRCULATOR PUMP**

- A. Acceptable Manufacturer: Bell & Gossett, or Taco, Armstrong.
- B. Pump and Motor Assembly: Hermetically sealed with motor and impeller on common shaft and designed for installation with pump and motor shaft horizontal.
- C. Casing: Bronze, with threaded or companion-flange connections, rated for a minimum of 150 psi working pressure, equipped with gage parts and suitable for operation at 225 degrees F.
- D. Impeller: Plastic.
- E. Motor: Single speed, unless otherwise indicated. Refer to Section 12, Plumbing Basic Materials.

### **PART 3 - EXECUTION**

#### **3.1 INSTALLATION**

- A. Inline pumps shall be installed with valves, and gages as detailed on the Drawings. Provide flanges or unions at all pump connections to facilitate dismantling.

- B. Diagrammatic representation of inline pumps on the Drawings is only for clarification of pump location. Actual positioning of pump in the piping system, orientation of pump and motor, and location of supports for pumps shall be in accordance with pump manufacturer's recommendations.
- C. Contractor shall carefully follow the Drawings in laying out and installing his work and he shall not deviate therefrom, except for structural or interior finish interferences.
- D. All pumps and accessories shall be carefully inspected for defects in workmanship prior to installation. Any item found unsuitable, cracked, or otherwise defective shall be rejected and removed from the jobsite. All pumps shall have factory applied markings, stampings, or nameplates with sufficient data for identification to determine their conformance with specified requirements.
- E. During construction all openings in pumps shall be kept closed except when actual work is being performed on that item. Closures shall be plugs, caps, blind flanges, or other items specifically intended for this purpose. Exercise all necessary care to prevent foreign objects from entering material.

\*\*END OF SECTION\*\*

**SECTION 120120  
SANITARY DRAINAGE**

**PART 1 - GENERAL**

**1.1 WORK INCLUDED**

- A. The Work of this Section shall consist of the labor, materials and equipment required for installation of the sanitary drainage system.
- B. Sanitary drainage shall be collected as indicated and connected to site sanitary lateral(s) at 5'-0" outside building.

**1.2 SUBMITTALS**

- A. Submit for approval in accordance with specified submittal procedures:
  - 1. Cleanouts
  - 2. Floor Drains
  - 3. Drain Traps
  - 4. Trap Guard Device
  - 5. Safe Pans
  - 6. Trench Drains and Covers
  - 7. Funnels
- B. Submit written verification of testing procedures specified herein.

**PART 2 - PRODUCTS**

**2.1 CLEANOUTS**

- A. Wall Cleanouts
  - 1. Acceptable Manufacturer: J.R. Smith Fig. 4422, or Zurn, Watts, Wade, Josam.
  - 2. Size: Cleanouts shall be full size of pipe to 4 inch and not less than 4 inch for larger pipe sizes.
  - 3. Plug: Bronze with tapered threads or with lead seal.
  - 4. Cover: Stainless steel shallow cover secured to plug with vandalproof screws.
- B. Exterior Cleanouts
  - 1. Acceptable Manufacturer: J.R. Smith Fig. 4251 U, or Zurn, Watts, Wade, Josam.

2. Size: Cleanouts shall consist of wye fitting, full size of pipe to 4 inch and not less than 4 inch for larger pipe sizes.
3. Plug: Bronze, countersunk, rectangular slotted, with emulsified lead paste.
4. Cover: Cast iron, non-skid, vandalproof, gasketed, watertight secured independently of plug.
5. Anchoring: 6 inch of concrete shall be poured around wye fitting, cleanout pipe and cleanout cover frame. Concrete shall terminate 6 inch below grade.

C. Floor Cleanouts, For Finished Floors

1. Acceptable Manufacturer: J.R. Smith Fig. 4021, or Zurn, Watts, Wade, Josam.
2. Size: Cleanouts shall consist of wye fitting, full size of pipe to 4 inch and not less than 4 inch for larger pipe sizes.
3. Plug: Bronze, countersunk, rectangular slotted, with emulsified lead paste and spigot outlet.
4. Cover: Scoriated nickel bronze top.

## 2.2 FLOOR DRAINS

A. Floor Drain FD-1

1. Acceptable Manufacturer: J.R. Smith Fig. 2010, or Zurn, Watts, Wade, Josam.
2. Body: Cast iron.
3. Outlet: Bottom.
4. Flashing Ring: Provided with weepholes.
5. Strainer: Adjustable, square with vandalproof screws. Nickel bronze or nickel brass.
6. Furnish with trap guard device.

B. Floor Drain FD-2

1. Acceptable Manufacturer: J.R. Smith Fig. 2120, or Zurn, Watts, Wade, Josam.
2. Body: Cast iron.
3. Outlet: Bottom.
4. Flashing Ring: Provided with weepholes.
5. Grate: Cast iron tractor grate, vandalproof.
6. Furnish with trap guard device.

## 2.3 DRAIN TRAPS

- A. Acceptable Manufacturer: J.R. Smith Fig. 7222, or Zurn, Watts, Josam.
- B. Where drains are specified without integral trap, furnish and install deep seal P trap of cast iron construction with hub inlet, spigot outlet.



## 2.4 TRAP GUARD DEVICE

- A. Acceptable Manufacturer: Proset Trap Guard, or J.R. Smith Quad Close, Sure Seal Trap Sealer
- B. Type: Barrier type trap seal protection device, inline floor drain trap sealer, elastomeric, neoprene rubber. Prevents the evaporation of the trap seal and the emission of sewer gases.
- C. Approvals: ASSE 1072-2007.

## 2.5 SAFE PANS

- A. Acceptable Manufacturer: Noble Company Chloraloy.
- B. Provide safe pans (sub pans) for all floor drains in floor slabs not installed on grade. Safe pans shall be constructed of chlorinated polyethylene concealed waterproof membrane, 0.040 inch thick (nominal), weldable with chlorinated polyethylene solvent bonding liquid or Xylene.
- C. Size: 36 inches square.

## 2.6 TRENCH DRAIN AND COVER (TD-1)

- A. Acceptable Manufacturer: J.R. Smith 9818.
- B. Material: Precast polymer concrete with integral metal rail edge construction, extra heavy duty.
- C. Frame: Sloped, furnished in 39 inch (1 meter) lengths.
- D. Cover: Furnished in 39 inch (1 meter) lengths, load class E, J. R. Smith 9870-461-M.

## 2.7 TRENCH DRAIN AND COVER (TD-2)

- A. Acceptable Manufacturer: J.R. Smith 2885-NB.
- B. Material: Cast iron construction, frame and nickel bronze cover, light duty.
- C. Frame: Furnish in 12 inch lengths.
- D. Cover: Furnished in 12 inch lengths, vandalproof.

## 2.8 FUNNELS

- A. Acceptable Manufacturer: J.R. Smith Fig. 3812, or Zurn, Watts, Wade, Josam.
- B. Body: Cast iron.
- C. Outlet: No hub or caulked.

## PART 3 - EXECUTION

### 3.1 INSTALLATION

- A. Drainage lines shall be properly vented, graded and trapped to conform to local and state requirements.
- B. Each fixture shall be vented and trapped. Each vent shall be extended through roof, or shall be loop vented into a common main, acceptable by code. Where a vertical vent riser connects to another vent riser, an inverted wye fitting shall be provided.
- C. Cleanouts shall be provided in soil and waste piping where shown, at the ends of all mains, at intersection of branches with mains, at base of vertical stacks, at intermediate points of long runs not exceeding 40 feet, and at additional locations required by local ordinances.
- D. Rough in and make final connections to equipment furnished by Owner. Verify locations for roughing in with equipment supplier prior to start of work.
- E. Unless indicated otherwise, horizontal sanitary and waste lines 2-1/2 inches and smaller shall be graded 1/4 inch per foot inside building. Horizontal sanitary and waste line 3 inches and larger shall be graded 1/8 inch per foot and in accordance with inverts indicated outside building.
- F. Floor drains and piping floor penetrations shall be sealed to prevent leakage to floor below.
- G. Sanitary and vent piping below floor on grade shall be minimum 2 inches inside diameter, no-hub.
- H. No-hub fittings shall have a pipe stop on the interior of the fitting as well as a stainless steel shield that surrounds the coupling material. Dual pipe clamps shall be installed around the shield.
- I. No-hub cast iron fittings shall be supported by clevis hangers. Wire, string, or strapping supports will not be permitted.
- J. Vertical sanitary and vent piping shall be supported at each floor with riser clamps. Pipe joints shall not occur at floor line.

### 3.2 PURGING AND TESTING

- A. Sanitary Piping, Gravity
  1. Water Test: The water test shall be applied to the drainage system either in its entirety or in sections after rough piping has been installed. If testing entire system, all openings in the piping shall be closed tightly, except for the highest opening in the system. The system shall be filled with water to point of overflow. If system is tested in sections, each opening shall be plugged tightly except for the highest opening in the section under test. Each section shall then be filled with water. A section shall not be tested with less than a 10 foot head of water. In testing successive sections, at least the upper 10 feet of the next preceding section shall be tested so that a joint or pipe in the building (except the uppermost 10 feet of the system) shall not have been submitted to a test of less than a 10

foot head of water. Test water shall be kept in the system, or in the portion under test for 1 hour before start of inspection. The system shall remain tight at all points throughout inspection. If any leaks occur, those areas shall be corrected and re tested.

2. Drainage and Vent Air Test: An air test shall be made by forcing air into the system until there is a uniform gauge pressure of 5 pounds per square inch (psi) (34.5 kPa) or sufficient to balance a 10 inch (254 mm) column of mercury. This pressure shall be held for a test period of at least 15 minutes. Any adjustments to the test pressure required because of changes in ambient temperature of the seating of gaskets shall be made prior to the beginning of the test period. If any leaks occur those areas shall be corrected and retested.

**\*\*END OF SECTION\*\***

## **SECTION 120130 INTERCEPTORS**

### **PART 1 - GENERAL**

#### **1.1 WORK INCLUDED**

- A. The Work of this Section shall consist of the labor, materials and equipment required for installation of the sanitary system interceptors.

#### **1.2 SUBMITTALS**

- A. Submit for approval in accordance with specified submittal procedures:
  - 1. Interceptors

### **PART 2 - PRODUCTS**

#### **2.1 OIL/SEDIMENT INTERCEPTOR**

- A. Acceptable Manufacturer: Highland Tank Model SB 051-750.
- B. Body: Constructed of high-strength, mild carbon steel, meeting ASTM specifications, with capacities, dimensions, construction, and thickness in strict accordance with Underwriters Laboratories, Subject UL-58 Standard for Safety, Steel Underground Tanks for Flammable and Combustible Liquids, September 30, 1997, Single Wall construction.
- C. Corrosion Control System: Shall be in strict accordance with Underwriters Laboratories Inc. Subject UL-1746 Standard for External Corrosion Protection Systems for Steel Underground Storage Tanks.
- D. Interceptor shall be fabricated, inspected and pressure tested for leakage before shipment from the factory by manufacturer as a completely assembled, single vessel ready for installation.
- E. Interceptor shall be cylindrical, horizontal, atmospheric-type steel vessel.
- F. Interceptor shall consist of inlet and outlet connections, internal influent nozzle, heavy duty sludge baffle, large sediment and oil pump-out access, effluent downcomer, fittings for vent, sampling, gauging, and lifting lugs.

## PART 3 - EXECUTION

### 3.1 INSTALLATION

- A. Install interceptors and complete piping connections in accordance with equipment manufacturer's recommendations. Submit manufacturer's printed installation instructions with operating and maintenance data at completion of Work.

**\*\*END OF SECTION\*\***

## **SECTION 120140 STORM DRAINAGE**

### **PART 1 - GENERAL**

#### **1.1 WORK INCLUDED**

- A. The Work of this Section shall consist of the labor, materials and equipment required for installation of the storm water drainage system.
- B. Storm water drainage systems shall be connected to the site drainage system 5'-0" from building.

#### **1.2 SUBMITTALS**

- A. Submit for approval in accordance with specified submittal procedures:
  - 1. Cleanouts
  - 2. Roof Drains
  - 3. Overflow Drains
  - 4. Downspout Nozzles
- B. Submit written verification of testing procedures specified herein.

### **PART 2 - PRODUCTS**

#### **2.1 CLEANOUTS**

- A. Wall Cleanouts
  - 1. Acceptable Manufacturer: J.R. Smith, or Zurn, Watts, Wade, Josam.
  - 2. Size: Cleanouts shall be full size of pipe to 4 inches pipe size and not less than 4 inches for larger pipe sizes.
  - 3. Plug: Bronze, countersunk, rectangular slotted, with emulsified lead paste.
  - 4. Cover: Chrome plated bronze face of wall cover secured to plug with vandalproof screws.
- B. Exterior Cleanouts
  - 1. Acceptable Manufacturer: J.R. Smith, or Zurn, Watts, Wade, Josam, Jones Manufacturing.
  - 2. Size: Cleanouts shall consist of wye fitting full size of pipe to 4 inches pipe size and not less than 4 inches for larger pipe sizes.
  - 3. Plug: Bronze, countersunk, rectangular slotted with emulsified lead paste.

4. Cover: Cast iron, non-skid, vandalproof, gasketed, watertight secured independently of plug.
5. Anchoring: 6 inches of concrete shall be poured around wye fitting, cleanout pipe, and cleanout cover frame. Concrete shall terminate 6 inches below grade.

C. Floor Cleanouts, For Finished Floors

1. Acceptable Manufacturer: J.R. Smith Fig. 4021, or Zurn, Watts, Wade, Josam.
2. Size: Cleanouts shall consist of wye fitting, full size of pipe to 4 inch and not less than 4 inch for larger pipe sizes.
3. Plug: Bronze, countersunk, rectangular slotted, with emulsified lead paste and spigot outlet.
4. Cover: Scoriated nickel bronze top.

## 2.2 ROOF DRAINS

A. Roof Drain RD-1

1. Acceptable Manufacturer: J.R. Smith, or Zurn, Watts, Wade, Josam.
2. Type: For installation in insulated precast concrete or insulated metal roof decks where insulation is sloped to roof deck providing a sump for roof drain.
3. Materials
  - a. Body: Cast iron.
  - b. Dome: Cast iron, rough bronze, aluminum or brass.
4. Body: Provide flashing collar and gravel stop, sump receiver and under deck clamp.
5. Dome: Lock type.
6. Outlet: Bottom, inside calk.

## 2.3 OVERFLOW DRAINS

A. Overflow Drain OFD-1

1. Acceptable Manufacturer: J.R. Smith, or Zurn, Watts, Wade, Josam.
2. Type: For installation in insulated precast concrete or insulated metal roof decks.
3. Materials
  - a. Body: Cast iron.
  - b. Dome: Cast iron, rough bronze, aluminum or brass.
4. Body: Provide flashing collar and gravel stop, extension flange, sump receiver, and under-deck clamp.
5. Dome: Lock type.
6. Outlet: Bottom inside calk.
7. Standpipe: Cut PVC standpipe to achieve ponding depth at base of drain.

## 2.4 DOWNSPOUT NOZZLES

### A. Downspout Nozzle OFDN-1

1. Acceptable Manufacturer: J.R. Smith 1770 or Zurn, Wade, Josam.
2. Material: Cast bronze body and flange.
3. Screen: Stainless steel.

## PART 3 - EXECUTION

### 3.1 INSTALLATION

- A. Horizontal rain water conductors and storm sewers within the building shall be graded 1/8 inch per foot or in accordance with inverts indicated on Drawings. Horizontal storm lines outside building shall be graded.
- B. Cleanouts shall be provided in storm piping, at ends of all mains, at intersection of branches with mains, at base of vertical stacks, at intermediate points of long runs not exceeding 40 feet, and at other points required by local ordinances.

### 3.2 PURGING AND TESTING

#### A. Storm Piping, Gravity (Either of the following testing methods may be used.)

1. Water Test: The water test shall be applied to the drainage system either in its entirety or in sections after rough piping has been installed. If testing entire system, all openings in the piping shall be closed tightly, except for the highest opening in the system. The system shall be filled with water to point of overflow. If system is tested in sections, each opening shall be plugged tightly, except for the highest opening of the section under test. Each section shall then be filled with water. A section shall not be tested with less than a 10 foot head of water. In testing successive sections, at least the upper 10 feet of the next preceding section shall be tested so that a joint or pipe in the building (except the uppermost 10 feet of the system) shall not have been submitted to a test of less than a 10 foot head of water. Test water shall be kept in the system, or in the portion under test, for 1 hour before start of inspection. The system shall remain tight at all points throughout inspection. If any leaks occur, those areas shall be corrected and re tested.
2. Drainage and vent air test. An air test shall be made by forcing air into the system until there is a uniform gauge pressure of 5 pounds per square inch (psi) (34.5 kPa) or sufficient to balance a 10 inch (254 mm) column of mercury. This pressure shall be held for a test period of at least 15 minutes. Any adjustments to the test pressure required because of changes in ambient temperature of the seating of gaskets shall be made prior to the beginning of the test period. If any leaks occur those areas shall be corrected and retested.

\*\*END OF SECTION\*\*



**SECTION 120150  
WATER CONDITIONING SYSTEM**

**PART 1 - GENERAL**

**1.1 WORK INCLUDED**

- A. The Work of this Section shall consist of the labor, materials and equipment required for installation of the domestic water conditioning system.

**1.2 SUBMITTALS**

- A. Submit for approval in accordance with specified submittal procedures:
  - 1. Water Softener
  - 2. Brine Injection System

**PART 2 - PRODUCTS**

**2.1 WATER SOFTENER B AUTOMATIC TWIN PROGRESSIVE SYSTEM**

- A. Acceptable Manufacturer: Marlo MR-300-2.5-TW –PROG or Aqua Treatment Service, Culligan.
- B. Softener Tanks: Carbon steel resin tank shall be internally lined with an epoxy coating and shall have a corrosion resistant exterior. Tank shall have a 100 psi working pressure, hydrostatically tested to 100 psi, and a temperature rating of 35 degrees F – 110 degrees F. Tank shall bear ASME label.
- C. Brine System: Brine tank shall be molded rigid polyethylene with a tight fitting cover. Shall include an automatic air check assembly to prevent drawing air into the system, and a safety float shut-off valve to prevent overfilling of the brine tank.
- D. Resin: Shall be of premium quality, strong acid, sodium form caution exchange. Each cubic foot of resin shall be capable of removing 30,000 grains of hardness as calcium carbonate when generated with 15 lbs. of salt.
- E. Automatic Controls: An automatic brass body control valve shall provide adjustable timing [for delayed regeneration] and the intervals for all steps associated with the regeneration cycle (backwash, brine draw, slow rinse, fast rinse, and brine refill).
  - 1. The alternating twin system shall allow for one tank to be in regeneration or standby while the other tank is in service.
- F. Internal Distribution: Softener tanks shall be equipped with a lateral distributor system consisting of a slotted PVC design. The distributor shall be covered with a gravel support bed.

- G. Pipes, Valves, and Fittings: Pipes shall be standard weight, galvanized mild steel. Fittings shall be 125 psi class, galvanized malleable iron.
- H. Pressure Relief Valve: Furnish and install a pressure relief valve in the discharge piping of the pressure vessel(s).
- I. Water Testing Equipment: Complete water testing kit shall be furnished for conducting soap test.
- J. Instructions: Manufacturer's printed instructions covering installation and operation data shall be delivered to Owner. Start-up and test of equipment shall be conducted by factory trained personnel.
- K. Warranty: Water Softener shall have a 1-year limited warranty against defects in materials, workmanship, and corrosion. In addition, the tank shall have a 5-year warranty against internal corrosion.

## 2.2 BRINE INJECTION SYSTEM BI-1

- A. Acceptable Manufacturer: Cope Company Salt.
- B. Tank:
  - 1. Material: Polyethylene.
  - 2. Dimensions: 135 inches long x 55 inches wide x 70 inches high.
  - 3. Capacity: 14,000 lbs. of salt and 247.5 gallons of salt brine.
  - 4. Performance: With a 55 degree F water temperature, system shall produce 41.25 gallons of 100 percent saturated brine every 15.5 minutes.
- C. Pump:
  - 1. Type: Salt suitable submersible pump. Installed inside the tank.
  - 2. Motor: 1/2 HP, 230V/1PH/60Hz.
  - 3. Performance: 10 GPM at 20 feet ahead.
- D. Pipe: 3/4 inch continuous roll plastic pipe.

## PART 3 - EXECUTION

### 3.1 INSTALLATION

- A. Install water conditioning equipment in accordance with equipment manufacturer's recommendations. Submit manufacturer's printed installation instructions with operating and maintenance data at completion of Work.

**\*\*END OF SECTION\*\***

## **SECTION 120160 WATER HEATERS**

### **PART 1 - GENERAL**

#### **1.1 WORK INCLUDED**

- A. The Work of this Section shall consist of the labor, materials and equipment required for installation of the domestic water heating equipment.

#### **1.2 SUBMITTALS**

- A. Submit for approval in accordance with specified submittal procedures:
  - 1. Water Heaters
  - 2. Expansion Tanks

### **PART 2 - PRODUCTS**

#### **2.1 DOMESTIC WATER STORAGE HEATER, GAS COMMERCIAL, HIGH EFFICIENCY**

- A. Acceptable Manufacturer: A. O. Smith BTH, or Bradford White E-Force.
- B. Heater Style: Standard vertical, AGA approved, condensing, ASME labeled and National Board number.
- C. Materials
  - 1. Tank: Welded steel.
  - 2. Tank Lining: Porcelain enamel (glass lined).
  - 3. Tank Jacket: Steel with baked enamel finish.
  - 4. Insulation: Blanket type glass fiber or polyurethane foam.
  - 5. Water Connections: Brass or bronze.
  - 6. Base and Legs: Steel or cast iron.
- D. Working Pressure: 150 psi.
- E. Fuel: Propane.
- F. Controls: Electronic control of ignition and temperatures up to 180• F.
- G. Venting: PVC, ABS, or CPVC pipe. Venting options shall include horizontal, vertical, and direct vent sealed combustion.

- H. Venting Accessories: Wall/roof termination kit with exhaust and intake terminals, roof/wall penetration accessories.
- I. Gas Pressure Regulator: Integral to heater.
- J. Temperature-Pressure Relief Valve: 3/4 inch, minimum, ASME.
- K. Manufacturer's Guarantee: 3 years.
- L. Compliance: ASHRAE/IESNA 90.1.

## 2.2 EXPANSION TANK

- A. Acceptable Manufacturer: Amtrol Series ST-C.
- B. Type: Diaphragm, vertical.
- C. Tank: Steel, bearing ASME label for unfired pressure vessels.
- D. Tank Lining: Polypropylene.
- E. Diaphragm: Custom molded butyl.
- F. Air Charge: Factory charged. Provide air charging valve on tank for field charging.

## PART 3 - EXECUTION

### 3.1 INSTALLATION

- A. Install water heating equipment in accordance with equipment manufacturer's recommendations. Submit manufacturer's printed installation instructions with operating and maintenance data at completion of Work.

**\*\*END OF SECTION\*\***

## **SECTION 120170 PLUMBING FIXTURES**

### **PART 1 - GENERAL**

#### **1.1 WORK INCLUDED**

- A. The Work of this Section shall consist of the labor, materials and equipment required for installation of plumbing fixtures and associated fittings and trim.

#### **1.2 SUBMITTALS**

- A. Submit for approval in accordance with specified submittal procedures:
  - 1. Water Closets
  - 2. Lavatories
  - 3. Sinks
  - 4. Mop Receptors
  - 5. Showers
  - 6. Shower Fittings
  - 7. Electric Water Coolers
  - 8. Emergency Shower/Eyewashes
- B. Substitute manufacturer's fixtures shall be similar in style, dimensions and quality to the basis of design manufacturer's specified model number.

### **PART 2 - PRODUCTS**

#### **2.1 MATERIALS**

- A. Fixtures shall be of one manufacturer, insofar as possible, and of first quality. Wall hung vitreous china fixture backings shall be drilled and tapped for mounting carriers specified.

#### **2.2 WATER CLOSETS**

- A. Water Closet WC-1
  - 1. Acceptable Manufacturer: American Standard 2257.103, or Kohler, Sloan.
  - 2. Type: ADA compliant, wall hung, flush valve type, 1.6 gallon per flush, vitreous china, siphon jet action, elongated bowl, 1-1/2 inch top spud, 18 inch high, floor to rim.
  - 3. Seat:
    - a. Acceptable Manufacturer: Kohler, or Beneke, Olsonite. Bemis.

- b. Extra heavy, elongated, white, open front, check hinge.
- 4. Battery Powered Flush Valve:
  - a. Acceptable Manufacturer: Sloan Optima 111-1.6XL SMO.
  - b. ADA compliant, 1.6 gallon per flush, less handle opening, battery powered infrared sensor, diaphragm or piston valve, chrome plated cover assembly with integral window, flush delay, override button, batteries, low battery flashing LED, infrared sensor adjustment, screw driver check angle stop with vandal resistant cap, sweat solder adaptor, adjustable tailpiece, vacuum breaker flush connection, spud coupling, and flange.
- 5. Carrier:
  - a. Acceptable Manufacturer: J.R. Smith No. 100, or Watts, Wade, Zurn, Josam.
  - b. Cast iron, adjustable, vandalproof trim.

## 2.3 LAVATORIES

### A. Lavatory L-1

- 1. Acceptable Manufacturer: American Standard 0355.012, or Kohler, Sloan.
- 2. Type: ADA compliant, 21 inch x 18 inch vitreous china, wall hung with anti-splash rim, drilled with centers to accommodate faucet and concealed arm carriers.
- 3. Faucet:
  - a. Acceptable Manufacturer: Delta 500.
  - b. Vandal resistant, single lever control, 0.5 gpm spray, open grid drain assembly, chrome finish.
- 4. Supplies:
  - a. Acceptable Manufacturer: McGuire 170LK, or Brasscraft.
  - b. 3/8 inch wall supplies, loose key angle stops, flexible tube riser, escutcheon, chrome finish.
- 5. Trap:
  - a. Acceptable Manufacturer: McGuire 8872C or Brasscraft.
  - b. 1-1/4 inch, 17 gage cast brass adjustable P-trap, cleanout plug, escutcheon, chrome finish.
- 6. Drain and Supply Line Covers:
  - a. Acceptable Manufacturer: True Bro Model 102W or Prowrap.
  - b. ADA compliant, flexible vinyl insulation installed on exposed drain piping, hot water piping and cold water piping.
  - c. ANSI A117.1-2003.
- 7. Carrier:
  - a. Acceptable Manufacturer: J.R. Smith 700, or Wade, Watts, Zurn, Josam.
  - b. Concealed arms with mechanical locking device, high strength steel uprights with block bases of bolting to floor construction.

## 2.4 SINKS

### A. Sink S-1

1. Acceptable Manufacturer: Elkay Series LR, or Just.
2. Type: Single bowl, type 304 stainless steel, 18 gage, self-rimming sound dampened underside, holes drilled to accommodate faucet.
3. Faucet:
  - a. Acceptable Manufacturer: T&S Brass B-2338.
  - b. Chrome plated, single deck mount base mixing faucet with swing spout and overhead spring and spray valve assembly and wall bracket.
4. Supplies
  - a. Acceptable Manufacturer: McGuire, or Brass Craft.
  - b. 3/8 inch wall supplies, loose key angle stops, flexible tube riser, escutcheon, chrome finish.
5. Drain Outlet:
  - a. Acceptable Manufacturer: Elkay LK-35, or Just.
  - b. Chrome plated brass drain, stainless steel basket strainer, chrome plated brass 1-1/2 inch O.D. tailpiece.
6. Trap: 1-1/2 inch P-trap with cleanout, chrome plated.

B. Sink S-2

1. Acceptable Manufacturer: Elkay Series LRAD, or Just.
2. Type: Single bowl, ADA compliant, type 304 stainless steel, 18 gage, self-rimming, 5-1/2 inch deep bowl, drain opening shall be located in back right side or back left side of bowl, sound dampened underside, holes drilled to accommodate faucet.
3. Faucet:
  - a. Acceptable Manufacturer: T&S Brass B-2338.
  - b. Chrome plated, single deck mount base mixing faucet with swing spout and overhead spring and spray valve assembly and wall bracket.
4. Supplies
  - a. Acceptable Manufacturer: McGuire, or Brass Craft.
  - b. 3/8 inch wall supplies, loose key angle stops, flexible tube riser, escutcheon, chrome finish.
5. Drain Outlet:
  - a. Acceptable Manufacturer: Elkay LK-35, or Just.
  - b. Chrome plated brass drain, stainless steel basket strainer, chrome plated brass 1-1/2 inch O.D. tailpiece.
6. Trap: 1-1/2 inch P-trap with cleanout, chrome plated.

C. Sink S-3

1. Acceptable Manufacturer: Elkay WNSF81362, or Just.
2. Type: Single bowl floor mounted sink with legs, type 304 stainless steel, 14 gage. Sink polished to a uniform satin finish. Channel rims, straight line styling. Bowl with center outlet pitched to drain. Sink supported on four stainless steel tubular legs, 1-5/8 inch OD with adjustable bullet shaped feet.
3. Faucet:
  - a. Acceptable Manufacturer: T&S Brass B-2187.

- b. Chrome plated, single wall mount mixing faucet with swing spout and overhead spring and spray valve and wall bracket.
  - 4. Supplies:
    - a. Acceptable Manufacturer: McGuire, or Brass Craft.
    - b. 3/8 inch wall supplies, angle stops, flexible tube riser, escutcheon, chrome finish.
  - 5. Drains:
    - a. Acceptable Manufacturer: Elkay LK-24-RT or Just.
    - b. Three drains, each consisting of stainless steel strainer, brass body and roto handle, 1-1/2 inch O.D. tailpiece.
- D. Sink S-4
  - 1. Acceptable Manufacturer: Elkay WNSF1362 (custom).
  - 2. Type: Single bowl floor mounted sink with legs, type 304 stainless steel, 14 gage, ADA compliant. Sink polished to a uniform satin finish. Channel rims, straight line styling. Bowl with center outlet pitched to drain. Sink supported on four stainless steel tubular legs, 1-5/8 inch OD with adjustable bullet shaped feet.
  - 3. Faucet:
    - a. Acceptable Manufacturer: T&S Brass B2187.
    - b. Chrome plated, single wall mount mixing faucet with swing spout and overhead spring and spray valve and wall bracket.
  - 4. Supplies:
    - a. Acceptable Manufacturer: McGuire, or Brass Craft.
    - b. 3/8 inch wall supplies, angle stops, flexible tube riser, escutcheon, chrome finish.
  - 5. Drains:
    - a. Acceptable Manufacturer: Elkay LK-24-RT or Just.
    - b. Three drains, each consisting of stainless steel strainer, brass body and roto handle, 1-1/2 inch OD tailpiece.
- E. Sink S-5
  - 1. Acceptable Manufacturer: Elkay WNSF81362, or Just.
  - 2. Type: Single bowl floor mounted sink with legs, type 304 stainless steel, 14 gage. Sink polished to a uniform satin finish. Channel rims, straight line styling. Bowls with center outlets pitched to drain. Sink supported on four stainless steel tubular legs, 1-5/8 inch OD with adjustable bullet shaped feet.
  - 3. Faucet:
    - a. Acceptable Manufacturer: T&S Brass B-2187.
    - b. Chrome plated, single wall mount mixing faucet with swing spout and overhead spring and spray valve and wall bracket.
  - 4. Supplies:
    - a. Acceptable Manufacturer: McGuire, or Brass Craft.
    - b. 3/8 inch wall supplies, angle stops, flexible tube riser, escutcheon, chrome finish.
  - 5. Drains:
    - a. Acceptable Manufacturer: Elkay LK-24-RT or Just.
    - b. Three drains, each consisting of stainless steel strainer, brass body and roto handle, 1-1/2 inch OD tailpiece.



F. Sink S-6

1. Acceptable Manufacturer: Elkay WNSF1362 (custom).
2. Type: Single bowl floor mounted sink with legs, type 304 stainless steel, 14 gage, ADA compliant. Sink polished to a uniform satin finish. Channel rims, straight line styling. Bowls with center outlet pitched to drain. Sink supported on four stainless steel tubular legs, 1-5/8 inch OD with adjustable bullet shaped feet.
3. Faucet:
  - a. Acceptable Manufacturer: T&S Brass B2187.
  - b. Chrome plated, single wall mount mixing faucet with swing spout and overhead spring and spray valve and wall bracket.
4. Supplies:
  - a. Acceptable Manufacturer: McGuire, or Brass Craft.
  - b. 3/8 inch wall supplies, angle stops, flexible tube riser, escutcheon, chrome finish.
5. Drains:
  - a. Acceptable Manufacturer: Elkay LK-24-RT or Just.
  - b. Three drains, each consisting of stainless steel strainer, brass body and roto handle, 1-1/2 inch OD tailpiece.

G. Sink S-7

1. Sink furnished by Owner.
2. Faucet:
  - a. Acceptable Manufacturer: T&S Brass B2187.
  - b. Chrome plated, single wall mount mixing faucet with swing spout and overhead spring and spray valve and wall bracket.
3. Supplies:
  - a. Acceptable Manufacturer: McGuire, or Brass Craft.
  - b. 3/8 inch wall supplies, angle stops, flexible tube riser, escutcheon chrome finish.
4. Drains:
  - a. Acceptable Manufacturer: Elkay LK-24-RT or Just.
  - b. Three drains, each consisting of stainless steel strainer, brass body and roto handle, 1-1/2 inch OD tailpiece.

H. Sink S-8

1. Sink furnished by Owner.
2. Faucet:
  - a. Acceptable Manufacturer: T&S Brass B-2338.
  - b. Chrome plated, single deck mount mixing faucet with swing spout and overhead spring and spray valve and wall bracket.
3. Supplies:
  - a. Acceptable Manufacturer: McGuire, or Brass Craft.
  - b. 3/8 inch wall supplies, angle stops, flexible tube riser, escutcheon chrome finish.
4. Drains:
  - a. Acceptable Manufacturer: Elkay LK-24-RT or Just.
  - b. Three drains, each consisting of stainless steel strainer, brass body and roto handle, 1-1/2 inch OD tailpiece.

## 2.5 MOP RECEPTORS

### A. Mop Receptor MR-1

1. Acceptable Manufacturer: Fiat, or Flore Stone.
2. Type: One piece precast terrazzo, integral cast drain, stainless steel protective cap on exposed sides, size as scheduled on Drawings.
3. Faucet:
  - a. Acceptable Manufacturer: T&S Brass B-0665-BSTP.
  - b. Polished chrome plated with vacuum breaker, lever handles, threaded spout, rubber hose, wall hook, loose key stops.
4. Accessories:
  - a. Acceptable Manufacturer: Fiat.
  - b. Mop Hanger: Stainless steel with three rubber tool grips.
  - c. Wall Guard: Heavy gage stainless steel.

## 2.6 SHOWERS

### A. Shower SH-1

1. Acceptable Manufacturer: Acryline G3636 ADA-3/4”.
2. Type: One piece seamless acrylic with grab bars, curtain rod, “L” shaped fold-up seat, drain, and slip resistant bottom. ANSI A117.1, ADA compliant.
3. Shower Valve:
  - a. Acceptable Manufacturer: Delta 1325-WSHDF.
  - b. Valve: Balanced-temperature and balanced-pressure shower set provided with color coded dial plate, lever handle, diaphragm balancing chamber with poppet type anti-line valves and inlet checkstops.
  - c. Shower Assembly: Chrome plated, self-cleaning volume control, 2.5 gpm flow restrictor, spray pattern vandalproof provided with anchor plate and remote lever diverter valve.
4. Water Retaining Strip:
  - a. Acceptable Manufacturer: Lasco, or Acryline.
  - b. Synthetic water retaining strip mounted at threshold of shower using a double sided adhesive backing.

## 2.7 ELECTRIC WATER COOLERS

### A. Electric Water Cooler EWC-1

1. Acceptable Manufacturer: Halsey Taylor HTV8BL-Q, or Oasis, Elkay, Acorn Aqua.
2. Type: Twin units, wall mounted, ADA compliant, lead free, electric water cooler shall have a minimum capacity of 8 gallons per hour of 50 degrees F drinking water with an 80 degrees F inlet water temperature and a room temperature of 90 degrees F. Unit shall be equipped with front and side push bar water controls, have a stainless steel receptor, and vinyl clad steel cabinet, color selected by Architect. Include flexible power cable with three pronged grounded male plug. Bubbler stream shall be self-regulating.

3. Trap: 1-1/4 inch P-trap with cleanout.
4. Supplies:
  - a. Acceptable Manufacturer: McGuire ST16, or Brasscraft.
  - b. 1/2 inch wall supply, brass stem, sweat inlet, 3/8 inch outlet.

## 2.8 EMERGENCY SHOWER/EYEWASHES

- A. Barrier Free Floor Mounted Combination Unit ESH-1
  1. Acceptable Manufacturer: Haws Model 8200, or Guardian.
  2. Shower: 10 inch diameter ABS plastic shower head, stay open chrome plated brass ball valve, rigid stainless steel pull rod, 30 gpm chrome plated brass flow control assembly, 9 inch diameter floor flange with 1-1/4 inch hot dip galvanized steel pipe.
  3. Eye/Face Wash: Spray heads which produce a spray pattern that covers entire facial area with dust covers which automatically release when eye/face was is activated, stainless steel push flag operates a stay open chrome plated brass ball valve with a stainless steel ball and stem, automatic pressure compensation devices for 30 - 90 psi.
  4. Sign: Emergency sign included.
  5. Shall meet ANSI Z358.1 requirements.

## PART 3 - EXECUTION

### 3.1 INSTALLATION

- A. Plumbing fixtures shall be installed square with wall, in line, and level, to give a uniform appearance. Plumbing trim and exposed supply and waste piping, including traps, shall be polished chrome plated brass, unless otherwise specified.
- B. Each hot and cold water connection to plumbing fixtures and equipment shall be valved, if not provided with integral stops as specified herein.
- C. Calk space watertight between plumbing fixtures and wall or floor; silicone, white for all white fixtures, clear for all other colors.
- D. Contractor shall be responsible to coordinate the orientation of all plumbing fixtures (i.e. left-hand, right-hand) with ADA requirements and general building conditions. Model numbers are listed for plumbing fixtures to illustrate a standard of quality for materials and indicate a specific style.
- E. Shower control valves provided with high limit stops shall be adjusted to a maximum hot water temperature setpoint of 105 degrees F.

3.2 CONNECTIONS TO EQUIPMENT SUPPLIED BY OTHERS

- A. Rough in and make final connections to equipment supplied by Owner. Each hot and cold water connection shall be valved. Verify locations for roughing-in with the equipment supplier, prior to beginning work.

3.3 TESTING

- A. Plumbing fixtures shall be filled with water and checked for leaks or retarded flow. Remove and clean all aerators.

**\*\*END OF SECTION\*\***

**SECTION 120180  
SPECIAL PIPING SYSTEMS**

**PART 1 - GENERAL**

**1.1 WORK INCLUDED**

- A. The Work of this Section shall consist of the labor, materials and equipment required for installation of the following piping systems:
  - 1. Compressed Air
  - 2. Acid Waste
  - 3. Vacuum
- B. Compressed air piping shall be extended from air compressor and distributed to areas and equipment specified herein.
- C. Acid waste shall be collected and extended to neutralization tank, and discharged to sanitary sewer system.
- D. Vacuum piping shall be installed for future vacuum pump and distributed to vacuum stations.

**1.2 SUBMITTALS**

- A. Submit for approval in accordance with specified submittal procedures:
  - 1. Air Compressors
  - 2. Air Dryers
  - 3. Filters/Separators
  - 4. Air Pressure Regulators
  - 5. Neutralization Tanks

**PART 2 - PRODUCTS**

**2.1 AIR COMPRESSOR**

- A. Acceptable Manufacturer: Quincy Series QRDT, or Gardner Denver, Ingersoll Rand.
- B. Type: Air cooled, reciprocating, two stage, oil-less, reciprocating, tank mounted compressor with v-belt drive and metal guard.
- C. Tank: Horizontal steel air receiver, ASME.

- D. Provided with pressure gage, ASME relief valve, check valve, air filter, pressure switch, service valve, and manual drain valve.
- E. Motor: NEMA, open drip proof.
- F. Warranty: 10,000 hours or 3 years.
- G. Controls: Start stop control, motor starting switch.
- H. Control Panel: Duplex, disconnect NEMA 12 enclosure, automatic alternation, lead select/auto switch, pilot lights, 120v control circuit, circuit breakers.

## 2.2 AIR DRYER

- A. Air Acceptable Manufacturer: Hankison Series PR, or Ingersoll-Rand, Zeks.
- B. Type: Refrigerated compressed air dryer, non-cycling, hermetically sealed refrigeration system, air cooled, hot gas bypass valve, high temperature light, full charge of CFC free refrigerant.
- C. Heat exchanger tube in tube design, non-fouling assemblies. Pressure vessel shall be U.L. approved.
- D. Filter: Two stage separator/filter, removes water droplets and solids 3 microns or larger.
- E. Cabinet: Heavy gage metal.

## 2.3 AIR FILTER

- A. Acceptable Manufacturer: Hankison, or Zeks, Ingersoll-Rand, Norgen.
- B. Type: 1 micron coalescer filter, housing shall be aluminum, zinc, or steel with corrosion resistance (interior and exterior), 250 psi maximum working pressure, internal/external automatic drain, differential pressure indicator and/or gages, liquid level indicator.

## 2.4 AIR FILTER/SEPARATOR

- A. Acceptable Manufacturer: Hankison, or Zeks, Ingersoll-Rand.
- B. Type: Remove solids and liquid 3 microns and larger, housing shall be aluminum, zinc, or steel with corrosion resistance (interior and exterior), 250 psi maximum working pressure, internal/external automatic drain, differential pressure indicator and/or gauges, liquid level indicator.

## 2.5 AIR PRESSURE REGULATOR

- A. Acceptable Manufacturer: Norgen.
- B. Regulators shall be non-relieving type T handle adjustment and integral pressure gage.

- C. Pressure Range: 2 to 125 psig.

## 2.6 NEUTRALIZING TANK

- A. Acceptable Manufacturer: Town & Country Plastic Inc., or Enfield.
- B. Type: Seamless high density polyethylene neutralization tank, with inlet, outlet and vent connections.
- C. Neutralizing Stone: Provide full charge of limestone.

## PART 3 - EXECUTION

### 3.1 INSTALLATION

- A. Install compressed air piping as indicated on Drawings with pipe, fittings, suitable drips, valves and hangers.
- B. Horizontal acid waste lines shall be sloped as indicated on Drawings. Change in direction shall be made with wye fittings, combination wye and eighth bends or one eighth bends. Offsets in acid waste pipes will not be permitted where offsets can be avoided. Offsets shall be made with 45 degree bends or similar fittings. Acid waste piping shall be installed in accordance with manufacturer's recommendations. Acid waste pipe exposed to damage by sharp surfaces shall be protected with grommets or sleeves of rubber or plastic.

### 3.2 PURGING AND TESTING

- A. Compressed Air Piping
  - 1. After installation of piping, but before installation of outlet valves, connections to compressor, lines shall be blown clear by means of oil-free dry air. Piping shall be tested with oil-free dry air to 175 psig. Test shall be held for 4 hours with a maximum pressure drop of 2 psi.
- B. Acid Waste Piping, Gravity

1. Water Test: Water test shall be applied to drainage system either in its entirety or in sections after rough piping has been installed. If applied to entire system, all openings in piping shall be tightly closed, except highest opening, and system shall be filled with water to point of overflow. If system is tested in sections, each opening shall be tightly plugged except highest opening of section under test, and each section shall be filled with water, but a section shall not be tested with less than 10 foot head of water. In testing successive sections, at least the upper 10 feet of next preceding section shall be tested, so that a joint or pipe in building, except uppermost 10 feet of system, shall not have been submitted to a test of less than 10 foot head of water. Water shall be kept in system or in portion under test for one hour before inspection starts. System shall then be tight at all points. If any leaks occur, those areas shall be corrected and section shall be retested.

**\*\*END OF SECTION\*\***



**SECTION 120190  
FUEL GAS PIPING AND SPECIALTIES**

**PART 1 - GENERAL**

**1.1 WORK INCLUDED**

- A. The Work of this Section shall consist of the labor, materials and equipment required for installation of fuel gas piping and specialties.
- B. Propane gas shall be extended from existing building propane gas system.

**1.2 RELATED SECTIONS**

- A. Section 220510, Plumbing Piping and Pipe Fittings: Propane gas piping and pipe fittings.

**1.3 SUBMITTALS**

- A. Submit for approval in accordance with specified submittal procedures:
  - 1. Gas Regulators
- B. Submit written verification of piping system testing procedures specified herein.

**PART 2 - PRODUCTS**

**2.1 GAS REGULATORS**

- A. Type GR-1
  - 1. Acceptable Manufacturer: Fisher Controls Series S 100, Actaris.
  - 2. Body: High tensile iron body and precision die cast aluminum diaphragm casing. Spring loaded type.
  - 3. Valve Disc and Orifices: Shall be renewable without breaking any pipe joints.
  - 4. Relief Valve: Built into unit which automatically opens to relieve excess pressure.
  - 5. Vent: Weather and insect resistant.

**PART 3 - EXECUTION**

**3.1 INSTALLATION**

- A. Piping

1. Extend propane gas piping to equipment or specified herein with suitable drips and cocks.
2. All welding of gas piping shall be performed by welders approved by local gas company.
3. All exterior gas piping shall be primed and painted.
  - a. Exterior semi-gloss, acrylic enamel: 2 coats over rust-inhibitive primer.
  - b. Color selected by Owner.
4. Provide cathodic protection on gas piping as required by local gas company.
5. Rough-in and make final connection to Owner furnished gas fired equipment. Verify locations for roughing-in with equipment supplier prior to start of work.

B. Gas Regulators

1. The gas regulator vent shall be extended to the exterior. Vent piping shall be installed per local codes and manufacturer's recommendations.
2. The gas regulator vent shall be sized as indicated on the drawings, but not less than the connection size to the regulator.

3.2 PURGING AND TESTING

- A. After installation of piping, but before installation of outlet valves, propane gas piping shall be blown clear by means of oil free dry air or nitrogen.
- B. Propane gas piping shall be tested in accordance with recommendations of the National Fire Protection Association (NFPA 96), American Gas Association, and local gas company.

**\*\*END OF SECTION\*\***

**SECTION 120200  
WIRING OF PLUMBING EQUIPMENT**

**PART 1 - GENERAL**

**1.1 WORK INCLUDED**

- A. The Work of this Section shall include the power and control wiring of plumbing equipment.

**PART 2 - PRODUCTS**

**2.1 MATERIALS**

- A. Plumbing Contractor shall provide equipment with controls, starters and related items as specified in various Sections of Section 12.
- B. Where plumbing equipment specified without starters or controllers, Electrical Contractor shall provide same as specified herein.
- C. Electrical Contractor shall provide all power wiring unless specifically noted otherwise.
- D. Plumbing Contractor shall furnish and install all control wiring unless specifically noted otherwise.

**PART 3 - EXECUTION**

**3.1 INSTALLATION**

- A. Plumbing equipment shall be wired in accordance with the following schedule:

Key:

<input type="checkbox"/>	Item furnished by.....
<input type="checkbox"/>	Item installed by....
<input type="checkbox"/>	Item wired by.....

the respective trade according to the following designations:

P = Plumbing Contractor  
E = Electrical Contractor

Plumbing Equipment Wiring Schedule																	
Equipment		Disconnect Means				Controllers					Control Devices						
		Remote Disconnect Switch	Integral Disconnect Switch	Wall Switch	Cord & Plug	Magnetic Motor Str	Combination Motor Str	Manual Motor Str	VFD with Disconnect	Contactor	Line Voltage Stat	Low Voltage Stat	Aquastat	Duct Smoke Detector	Control Panel	Flow/Press/Level Switch	BAS/ATC Control
Gas Fired Water Heater DWH-1 & DWH-2	P							P									
	P							P									
	E							E									
Recirc. Pump CP-1	P											P					H
	P											P					H
	E											E					H
Air Compressor AC-1	P													P			
	P													P			
	E													E			
Air Dryer AD-1	P																
	P																
	E																
Electric Water Cooler EWC-1	P				P												
	P				P												
	E				E												

B. Unless noted, Contractor responsible for wiring of an item shall be responsible for furnishing and installing all wiring for that item and making all connections associated with this wiring.

**\*\*END OF SECTION\*\***



### Standard Equipment

#### S11111TecTri Showerhead

Standard showerhead is 3.1" (78.7mm) diameter highly visible yellow impact-resistant plastic (Model S19-310F includes a 1.00" [273mm] diameter corrosion-resistant stainless steel shroud). High performance corrosion-resistant stainless steel showerhead mixtures 1.5" (38mm) in diameter (S.19-310FSS only). Spin Tee drench showerhead features integral 22 GPM flow control, conserving water and helping to accurately size your tepid water system.

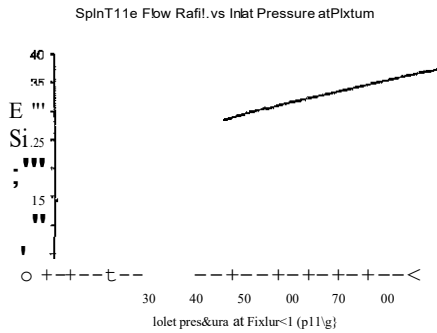

#### Shower Valve

Chrome-plated brass 1" FPT stay-open ball valve. Operated by a stainless steel rod with triangular handle. S-19-310FSS is all stainless steel.

#### Eye Wash Bowl

10" (254mm) diameter yellow impact-resistant plastic or 10.1" (273mm) diameter corrosion-resistant stainless steel.

#### Standard Sprayhead Assembly

Chrome-plated brass sprayhead with twin soft-flow eyewash shields and protective sprayhead covers. Safe, steady water flow under varying water supply conditions from 30-90 PSI is assured by integral flow control in the sprayhead assembly. S19-310FSS is stainless steel.

#### Eyewash Valve

Chrome-plated brass 1/2" MPT stay-open ball valve. Hand operated by highly visible yellow PVC push handle. S19-310FSS is all stainless steel.

#### Pipe and Fittings

1/2" galvanized steel with BradTec & Jfety yellow coating. S19-310FSS is stainless steel.

#### Water Supply

1/2" MPT.

#### 191 Local codes may require the installation of a backflow prevention valve

to complete proper installation. Compliance with local codes is the responsibility of the installer. Valve must be tested annually to verify that it is functioning properly. Backflow prevention valves are not included with this fixture and may be supplied by the contractor or purchased from Bmdle\_v Corporation.

# Bracley 9

## 519-310, S19-310F, S19-310FSS, S19-310SB Combination Drench Shower/Eyewash Unit

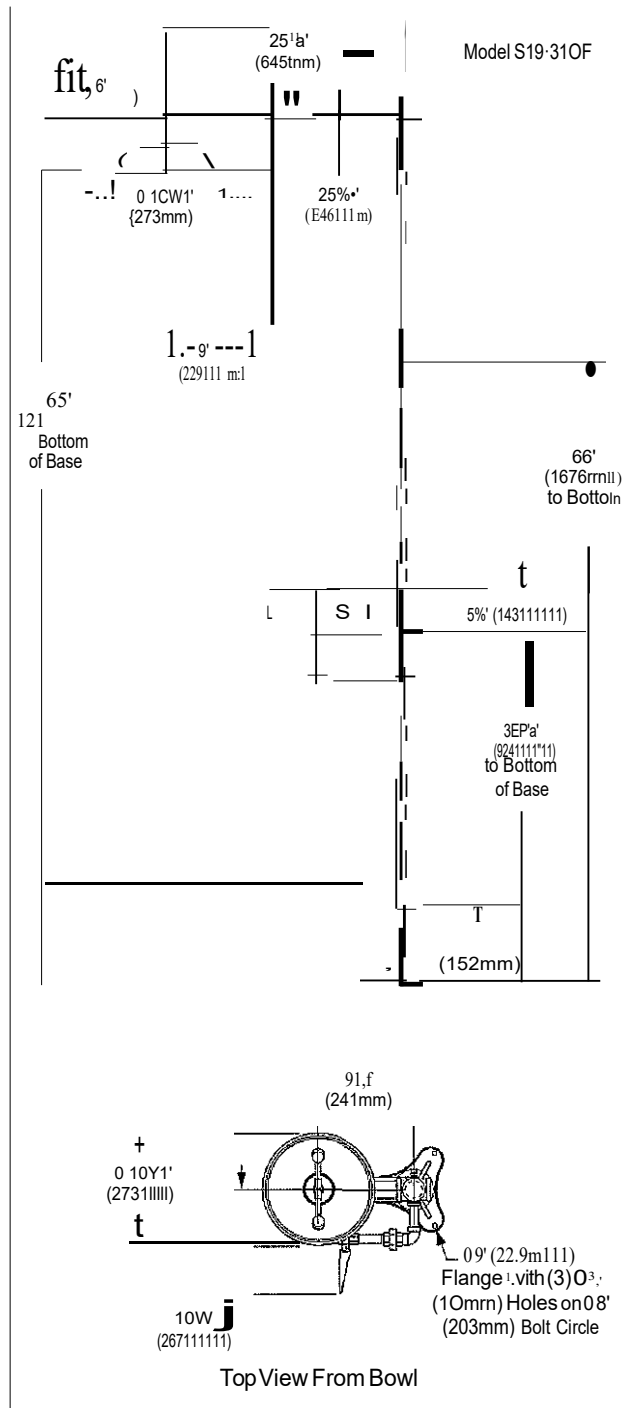
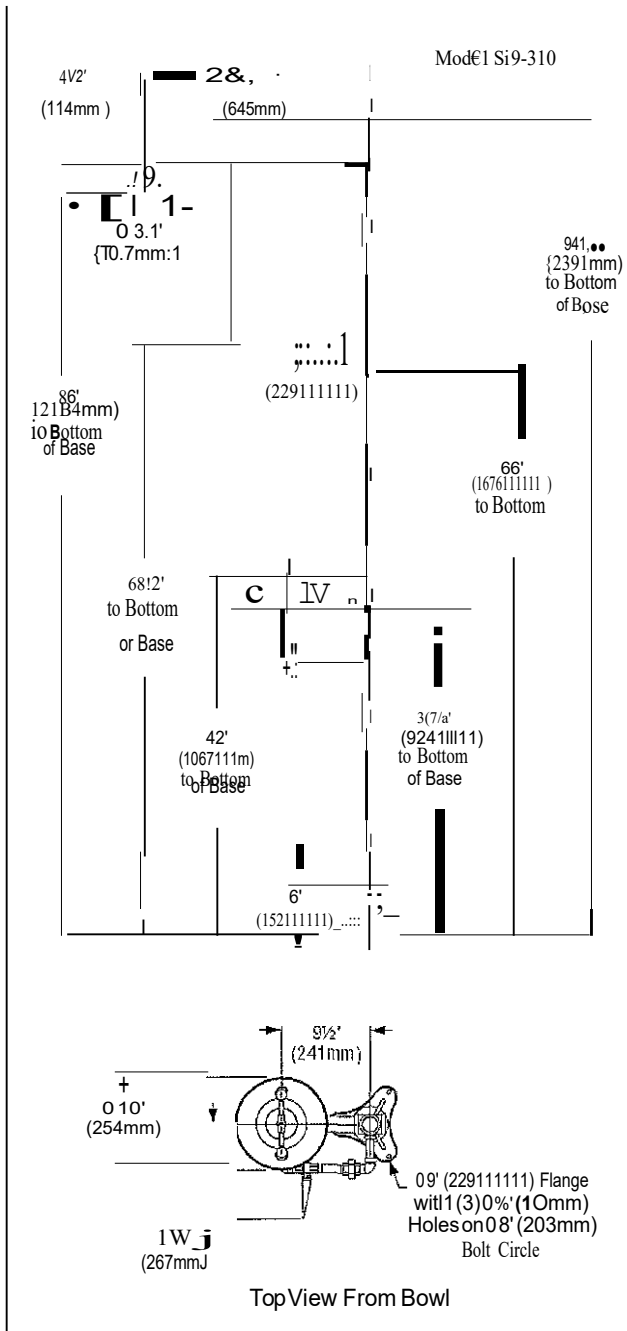

All dimensions assume 1/7" standard thread engagement. Variations in manufacturing allow for +/- 1/8" (3mm) per threaded joint. To find the tolerance of a dimension, add the number of threads in between a dimension and multiply it by 1/7" (3mm)

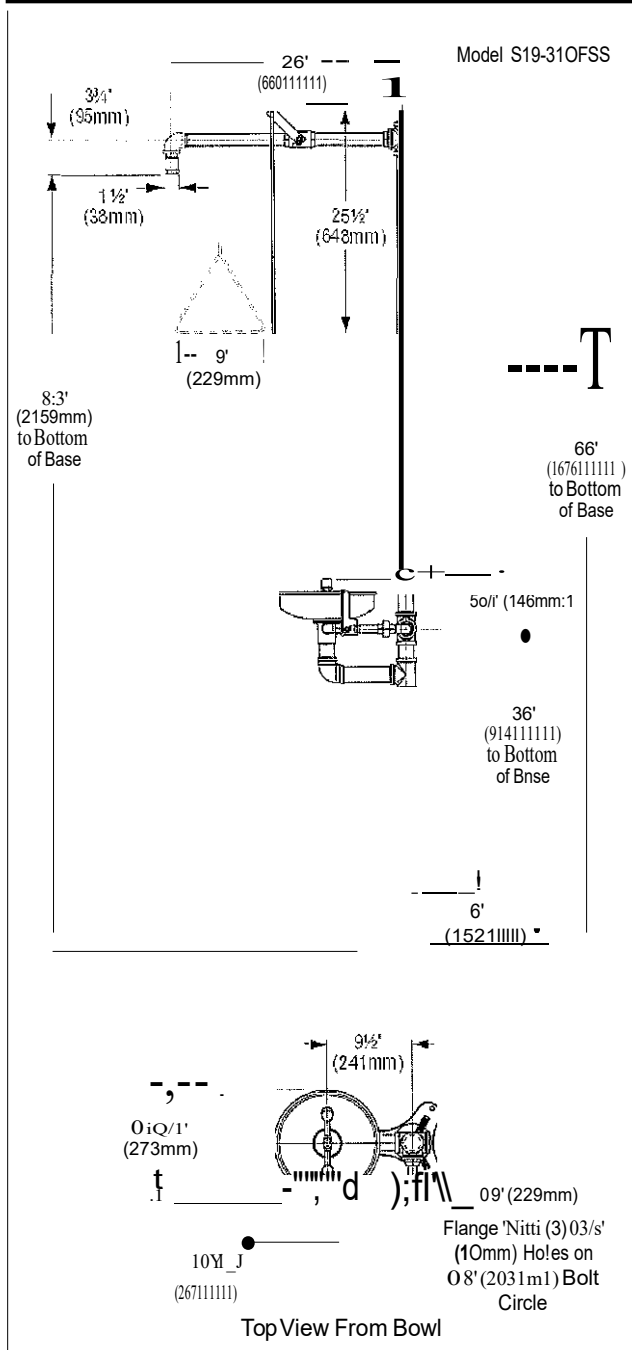

All dimensions assume standard thread engagement. Variations in manufacturing allow for +.1" (.3mm) per thread joint. To find the tolerance of a dimension add the number of thread joints in between a dimension and multiply it by .4" (.3mm).

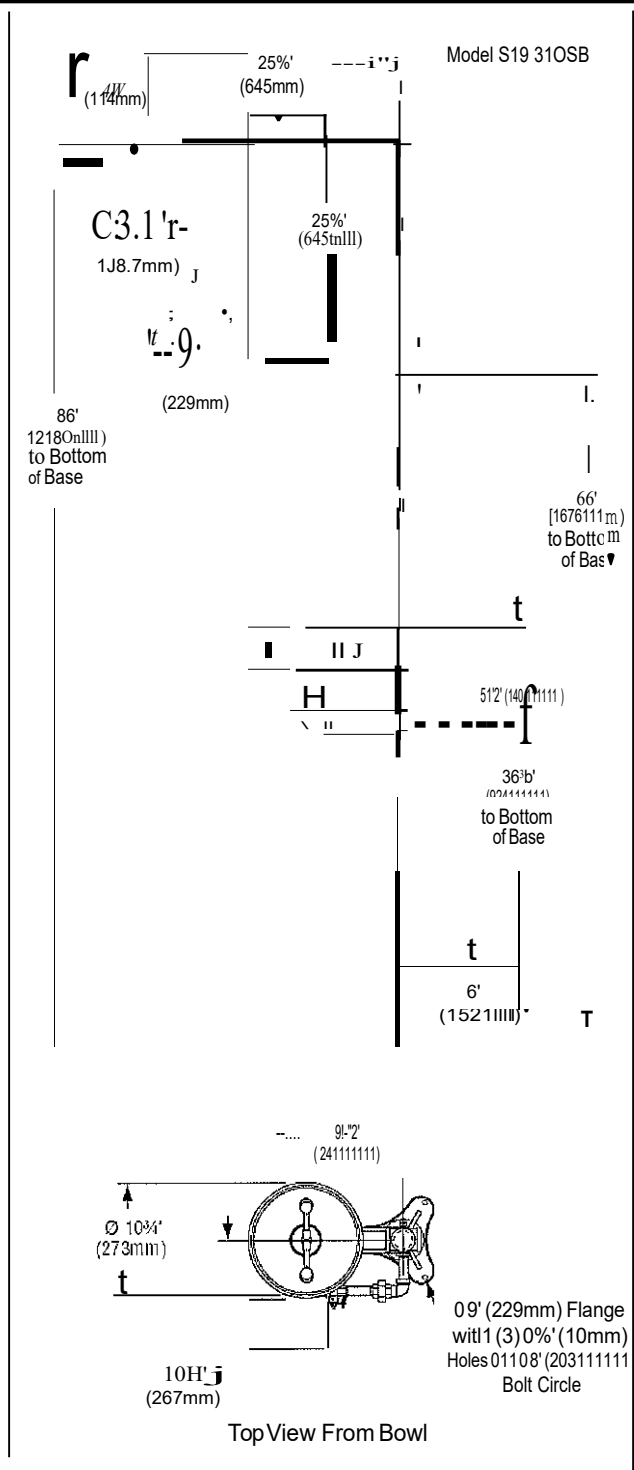



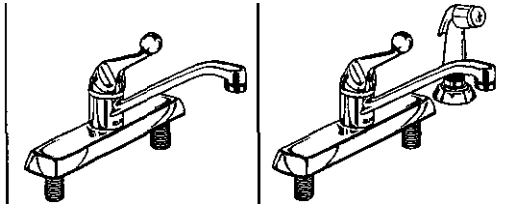

12Q ... I

42

Submitted Model No.: \_\_\_\_\_

Specific Features: \_\_\_\_\_

# © DELTA.

## ICITCHEN FAUCETS

- Single Handle
- Deck Mount
- 3 and 4 Hole Sink Applications
- 8" Centers
- Quick Snap® Vegetable Sprayer Hose Installation on Model 420 Series

c@us

LISTED

UL U81 & to US and Canadian  
Safety Standards and Class 1111d  
in accordance with  
ANSI/NSF 61  
21PL

### COMPLIES WITH:

- ASME A112.18.1
- CSA 8125
- NSF 61
- ITT Indicates ADA compliance to LQJ ICC/ANSI A117.1
- LAPMO listed
- CSA Certified

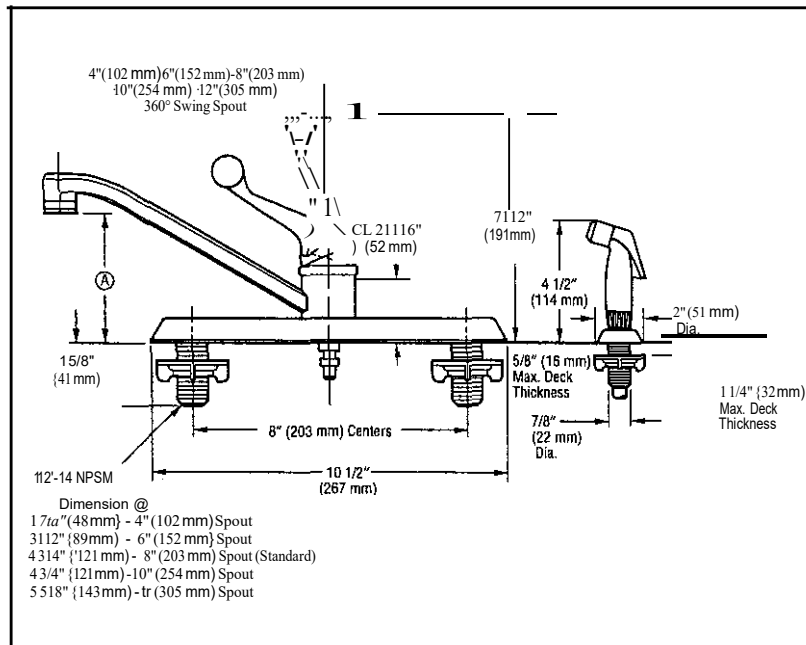

- Single handle kitchen deck faucets for mounting on three and four hole sinks
- Solid brass fabricated body.
- 8" /203 mm) long spout swings 360°.
- Lever handle. Control mechanism shall be of the rotating stainless steel ball type with replaceable non-metallic seats operating in stainless steel lined sockets.
- Control handle shall return to neutral position when valve is turned off.
- 1/2"-14 NPSM threaded male inlet shanks.
- Model 420 series with spray attachment has anti-siphon device as integral part of valve body.
- Quick Snap® vegetable sprayer hose installation on model 420 series.

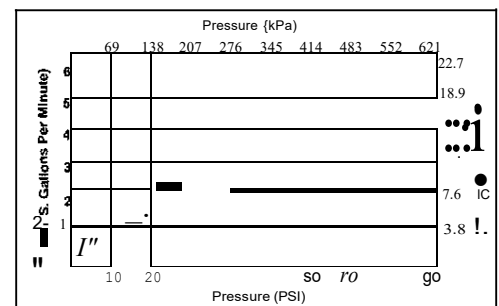

Delta reserves the right (1) to make changes in specifications and materials, and (2) to change or discontinue models, both without notice or obligation. Dimensions are for reference only.

Standard Features	
Washerless	
Three Hole Installation	
Four Hole Installation	
Lever Handle	
8" (203 mm) Long Spout Sw'ings 360°	
1/2" - 14 NPSM Male Threaded Inlet Shanks	
45" (1143 mm) Quick Connect Hose and Spray Assembly	
White Sprayhead	
Chrome Finish	

Available Options for Field Conversion:

- 4" (102 mm) long swing spout. Order RP5881.
- 6" (152 mm) long swing spout. Order RP9633.
- 10" (254 mm) long swing spout. Order RP5653.
- 12" (305 mm) long swing spout. Order RP6042.
- 6" (152 mm) long elbow handle with red/blue indicators. Order RP5645.
- Swivel Aerator. Order RP2189.

**.DE LTA.**  
FAUCET COMPANY

Indianapolis, Indiana 46280  
A Division of Masco Corporation of Indiana  
© 2002 Masco Corporation of Indiana

ffe

Jfo

IP:

500/501

510-wF

16.1

520

505

1/2" - 14 NPSM

Submitted Model No.:

Specific Features:

# DELTA LAVATORY FAUCETS

- Single Handle
- Deck Mount
- 2 and 3 Hole Sink Applications
- 4" Centerset

c@us LISTED

UL Uat&d10US and Canadian O  
 Safety Standards listed Classified O  
 To accordance with I  
 ANS/NSF610  
 21PL



COMPLIES WITH:

- ASME A112.18.1M-1996
- CSA 8125-93
- Indicates ADA compliance to LQ: CABO/ANSIA! 17.1-1992
- JAPMO Listed
- CSA Certified
- ASTM F409 for non-metallic drain

STANDARD SPECIFICATIONS:

- Single handle lavatory deck faucets for exposed mounting on two and three hole sinks.
- 4" (102 mm) centerset
- Solid brass fabricated body.
- 4 1/2" (114 mm) long spout

of the rotating stainless steel ball type with replaceable non-metallic seats operating in stainless steel lined sockets.

- Control handle shall return to neutral position when valve is turned off.
- Models 500, 501 and 510 and 520 Series supplied with 3/8" O.D. copper supply tubes.
- Models with suffix 'WF' supplied with 1/2"-14 NPSM adapters.
- Models 505 and 525 Series supplied with 1/2"-14 NPSM threaded male inlet shanks.
- Models with Snap-N-Pop-Up™ drain have polypropylene pop-up type fitting with plated flange and stopper.
- Models with metal drain have pop-up type fitting with plated flange and stopper.

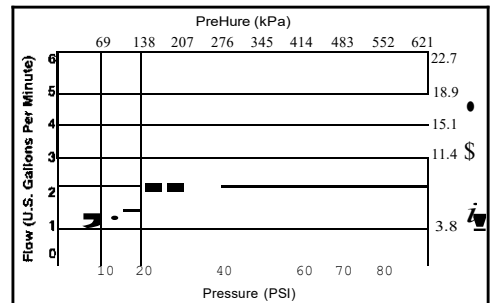
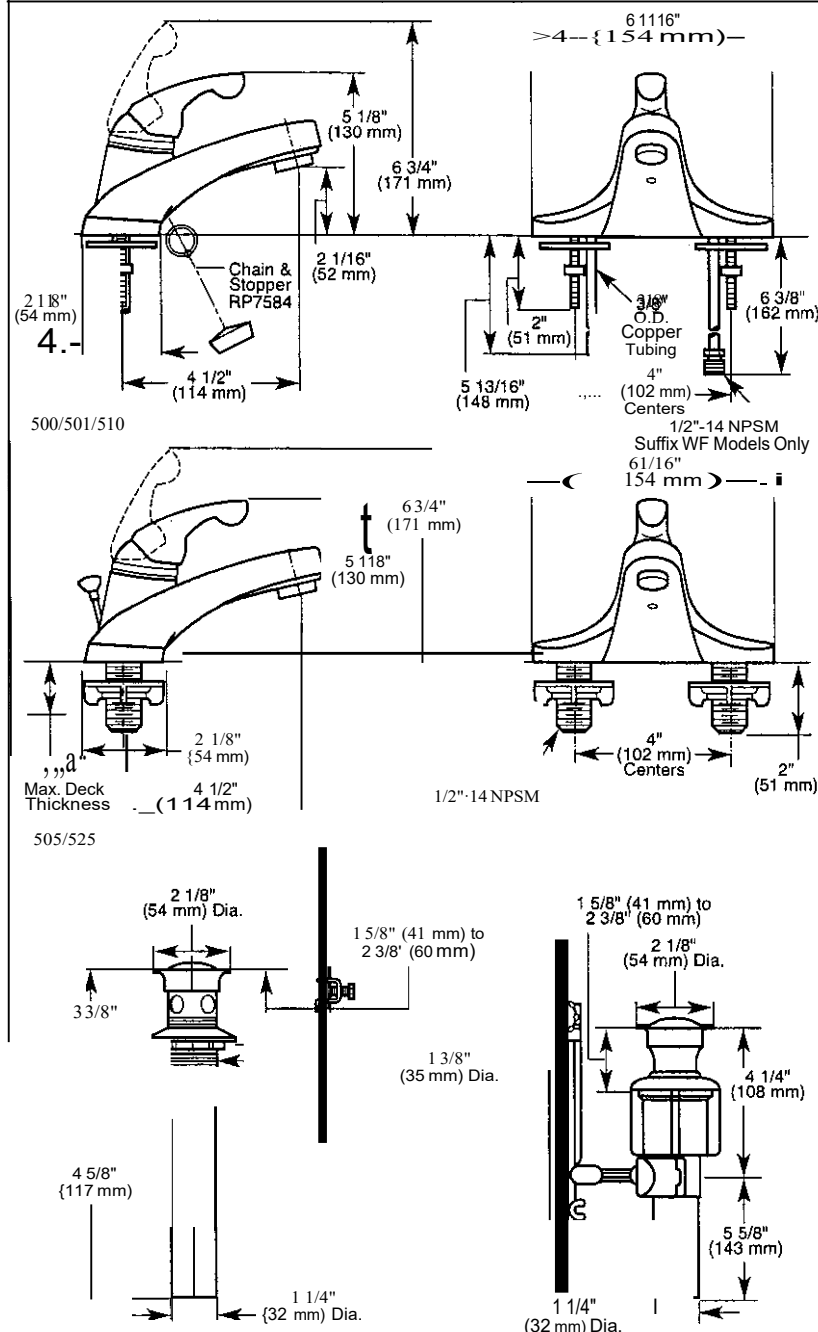

Delta reserves the right (1) to make changes in specifications and materials, and (2) to change or discontinue models, both without notice or obligation. Dimensions are for reference only.





# T&S BRASS AND BRONZE WORKS, INC. -

2 SADDLEBACK COVE / P.O. BOX 1088 / TRAVELERS REST, SC 29690

PHONE 800-476-4103

FAX 864- 834-3518

REG./A2501  
ISO #9002

Model No.

B-0665-BSTP / R

Item No.:

Job Name:

Architect/Engineer Approval:

*(Handwritten initials)*

Notes:

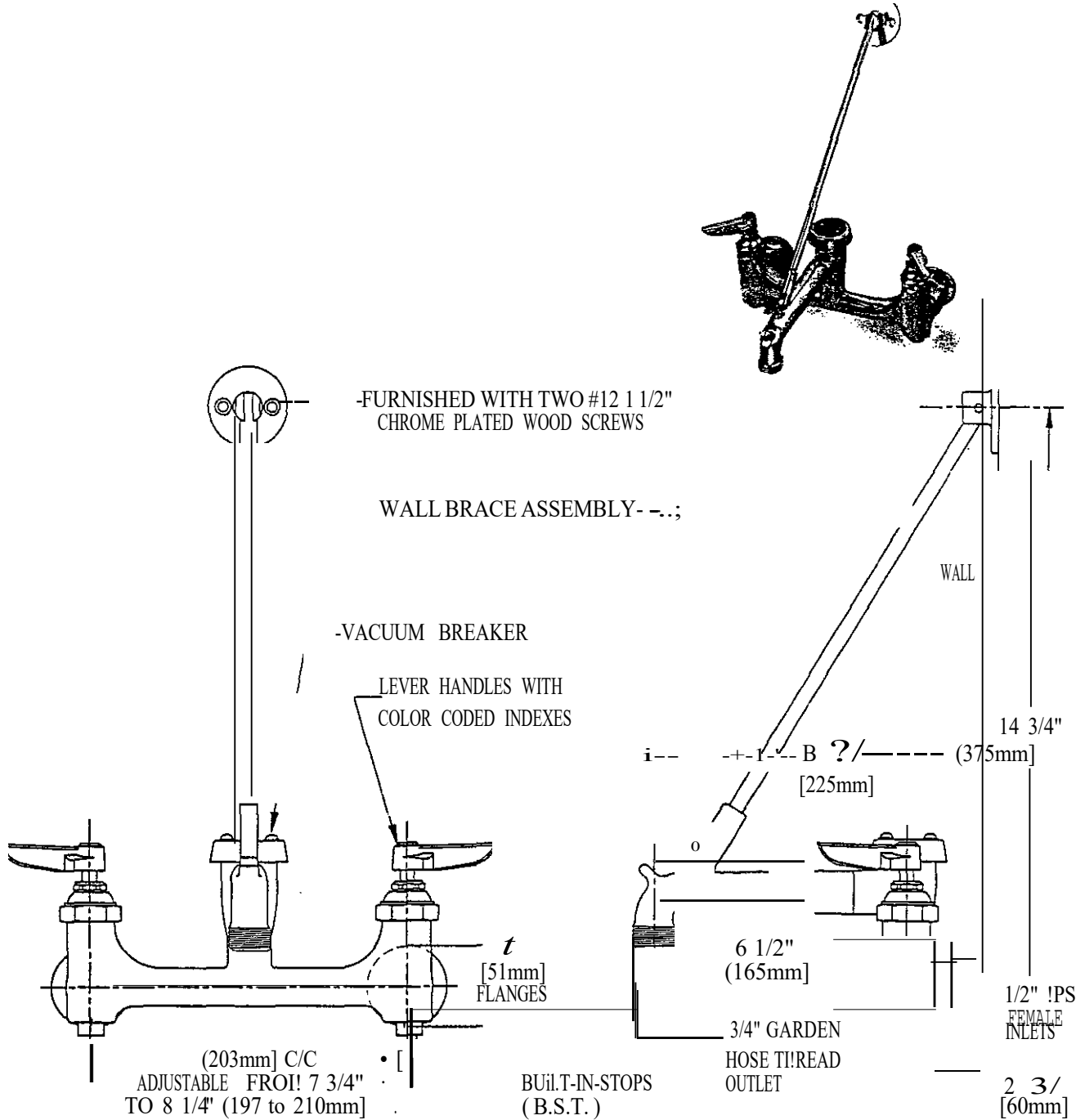

Product description:

SERVICE SINK FAUCET W/ BUILT IN STOPS, VACUUM BREAKER, LEVER HANDLES, WALL BRACE, AND AVAILABLE WITH ROUGH OR POLISHED CHROME FINISH

	MW	ca e: 3" = 1'
CA		a e: 1 1/22/95

# Models! Mode/os 120 & 420 Serie

RP5645  
 Handle w/Set Screw-Red/Blue Indicators  
 Manija con Tornillo de Ajuste-Indicadores: Rojo/Azul

P5

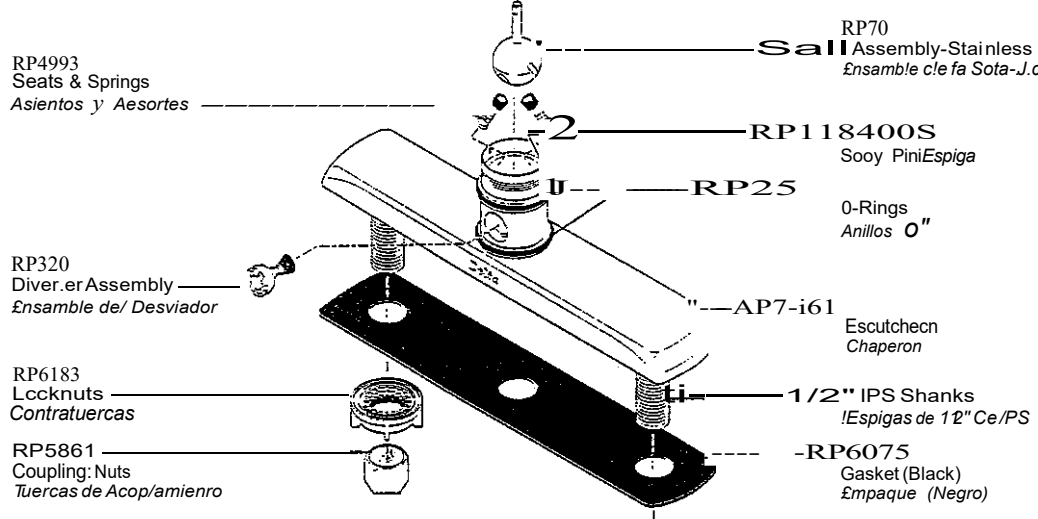
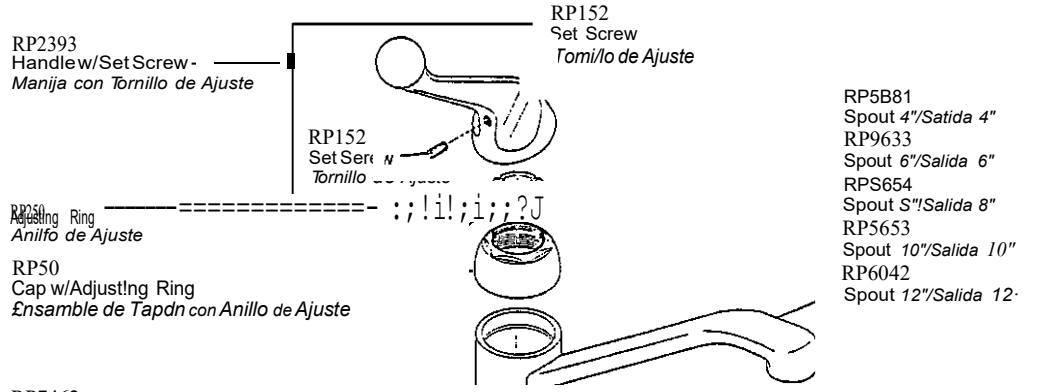

<p>RP22967          Spray Head/Cabeza def Rociador</p> <p>RP6011          RP26878 (6' Hcse/Manguera 6')          RP26879 (8' Hcse/Manguera 8')</p> <p>RP6015          Support Assembly/Saporte def Rociador</p>	<p>RP1974          Wrench-Handle/Adiusting Ring          Uavanija/Anillo de Ajuste</p>	<p>RP3614          Repair Kit          Herramientas para Reparaciones</p>
---	--	---

*Single Handle Kitchen Faucet 3 Hole without spout*

AN-09-01 TUE 12:06 PM

WSC HARRISSBURG

FAX: 71 72331 910

PAGE" 5

**Delta Single Handle Kitchen Faucets**

• 3 Hole Installation  
 • 2.0 gpm @ 60 psi  
 7.6 l/min @ 414 kPa

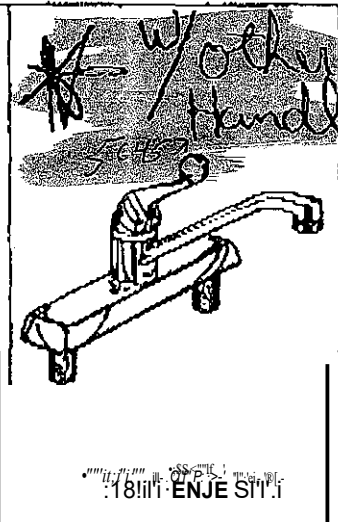
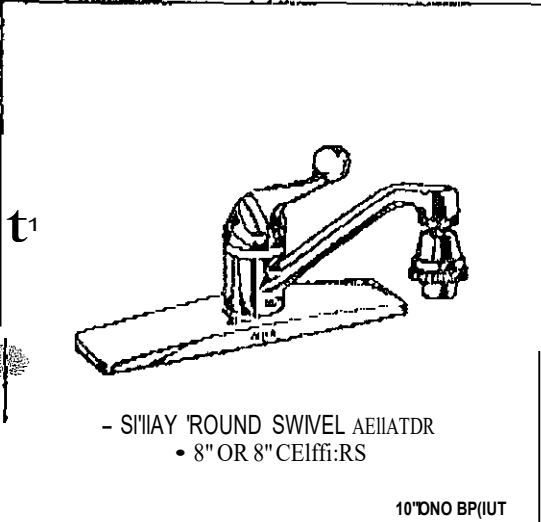

• Wall installation  
 • 8" Centers  
 • 8" Long spout swings 3600  
 • Lever handle  
 • Standard with  
 • 2.0 gpm @ 80 ps.I  
 7.6 J.)mln@ 551cPa

**.GSJADA**

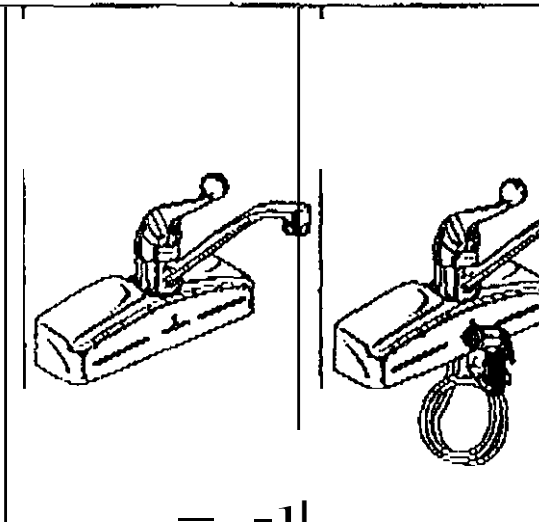

FINISH	MODEL NO	PRICE
Chrome	110	113.10
Chrome	110	114.75
Chrome	110	111.65

FINISH	MOC?,EL No.::=	PRICE	CASE aOAtffITY
Chrome	200	137.5	3
Chrome	275	I-	3

# Delta Single-Handle Kitchen Faucets

*4 Hole*  
*1" Spout*

**4-Hole Installation**

8" Long spout  
swings 360°  
Lever handle

Straight staggered  
supply tubes

2.0 gpm @ 60 psi  
7.6 L/min @ 414 kPa

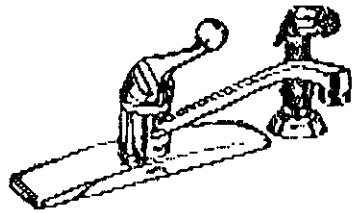

• 6" OR 8" CENTERS

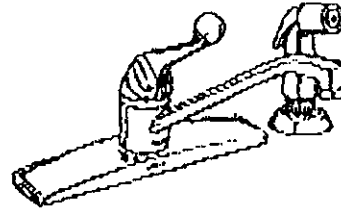

• 6" up CENTERS

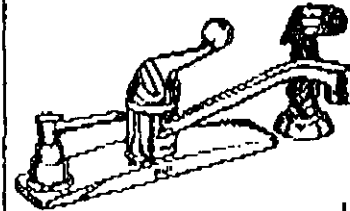

• 1" CENTERS

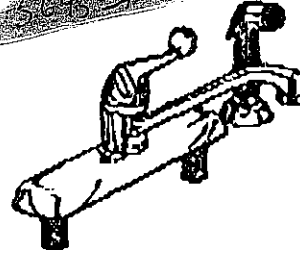

• 8" CENTERS

*4 Holes*  
*1" Spout*  
*Other Handle*

10" OF SPOUT

FINISH	MODEL NO.	PRICE	CASE QUANTITY
Chrome	400	17.45	12
White	400-WHWF	172.00	1
Chrome	400-WESPW	131.41	12
Chrome	400-0	154.55	3
Chrome	420	139.10	



# Single Handle Kitchen Faucets Manya de Palanca para Fregadero

Delta  
RP 5645

## Models/Modelos 101 & 175 Series

RP2093&

Handle W/Set screw  
M.mija COil Tor11/16  
de A1usta

RP152  
Set Screw

Torroto dA1uslc

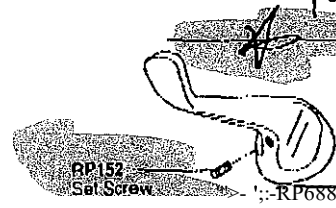

RP5645  
Handle w/Set Screw  
Red/Blue Indicators  
Manija con Tornillo  
de Ajuste  
Indicadores: Rojo/Azul

Handle for Low  
faucets  
w/w/o  
Spray

RP5QA

Capw/AdjJsting Au+g  
Ensambls de J'sp6n cnn  
Anillo de Ajuste

RPS654A

Spout e+Sallds a  
RP5853A  
spoul 10 1st<ta 10  
RP804U

Spout 12"/Sslida 1-

RP618 (f.J(ceplJ-IDF mor.lels n1frd. artar 2-7-00)  
(Exccplo mo\_dr.los flDF fsbfre 11 do dC.'lpr16; de 2-700)  
Cam Pacl<mg!Lava y Empaquc

RP330A

Aerator

Almador

RP246

Aerator w/Wrench-Va11dal AQSistanl

Rsslstenla aJ Msflraro

RP6420

Wrench/Llave

RP2109

Swivel Acratar/G/roll)1o Alre.adut

RP1184QOS

Body Pm/E8pfga

BauAssemblr:-\$tainlC\$Stcol---

EfismbfQ do ls. Bo/-  
Acero Inoxlcfblo

AP4993  
Sats & Springs

Asfenlosy Rssso1tr

RP2S

O-Rings

Antnos "O"

APJ20

Divcnar Assnmbly  
CnsambfJ dat OesviiL Uor

RP5786&

Base w/Gaske1

Bnse con Empaque

1/2" PS. Adaptors--WF ModeJi; Orly

Ad<lpf.9dDf8\$ de JPS 112-S610 Modelos WF

RP5861

Coupling Nuts-WF Modols Only  
Tuerc. 1s de Acoplam/enta-  
S6to Modcfos y/f

AP6803

Mounlmg Brac:kcl  
Abrnzadera do Manlur:

RPt:169+

Spacer

sepcirador

RPS785

Nut & Wrench  
TIIBtcB

RP30394 - 101 & 175 Series  
Thick Deck Mounting Kit (For 2 1/2" Max. Thick Decks)  
Juego de herramientas para instalaci6n en bordes gruesos  
(Para 2 1/2" max de grosor de bordes)

-nP22gs7  
Spray HcdlC 1hC1Z del Re<;iRdor

RP6011

RP2687111 (6' HosEl/Msngu&f6')  
RP26879 (8' Hose/Manusra 8')  
Spray & Hoio p.embl  
En58111blo de la M11ngue1ay Raci.1dot

nP0015

Support Ai;smby/Soportlo del RociJctor

AP26\$BOAL  
OP26880WH  
Spray H.,11d1Cob11zs de/ Raciador

RP17786 (White/Blanco)  
RP17116AL\*

Spray & Hose Assembly  
Enssmbf(l dB la M-Jngusra y Radadar  
RP6015WA: (Almotir;t/Afrn9tldf8)  
PGD!SWW (White/Blanco)  
Support Asctnbly  
Soporte eel RociuJor

RP194  
Wrench-H1Jndla/  
Adjusting Ring  
Llave-ManUal  
Anillo dQ Ajusttl

RP3614  
Repair Kit  
Hertamfentas pafll.  
Rsparac:IOms





**Cdij** **IPONENT VALVES** *use Brass Craft* **R6 #276A**  
 FOR LAVATORY, CLOSET AND SINK SUPPLIES

*Eastman*

**--- IPRESSION STOPS FOR 3/4" AND 1/2" O.D. TUBE**

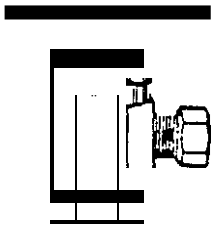

Iron Pipe Inlet

CATALOG NO.	DESCRIPTION	WEIGHT Per 100	●●●UST EACH C
44C	1/2" O.D. x 1/2" I.P.T. Angle Stop	32 tbs.	\$... ..
63C	3/8" O.D. x 3/8" I.P.T. Angle Stop	32 tbs.	
64C	3/8" O.D. x 1/2" I.P.T. Angle Stop	32 tbs.	
74C	1/2" O.D. x 1/2" I.P.T. Angle Stop	32 lbs.	
83C	1/2" O.D. x 3/8" I.P.T. Angle Stop	33 lbs.	
84C	1/2" O.D. x 1/2" I.P.T. Angle Stop	33 lbs.	

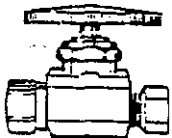

Iron Pipe Inlet

63CS	3/8" O.D. x 3/8" I.P.T. Strt. Stop	38 lbs.
64CS	3/8" O.D. x 1/2" I.P.T. Strt. Stop	36 lbs.
83CS	1/2" O.D. x 3/8" I.P.T. Strt. Stop	39 lbs.
84CS	1/2" O.D. x 1/2" I.P.T. Strt. Stop	36 lbs.

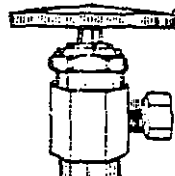

Sweat Inlet

SWC-60	1/2" O.D. x 1/2" Norn. Angle Stop	33 lbs.
SWC-68	3/8" O.D. x 3/8" Norn. Angle Stop	33 lbs.
SWC-70	3/8" O.D. x 1/2" Norn. Angle Stop	33 lbs.
SWC-80	1/2" O.D. x 1/2" Norn. Angle Stop	33 lbs.
SWC-88	1/2" O.D. x 1/2" Norn. Angle Stop	33 lbs.



Sweat Inlet

SWC-60S	3/8" O.D. x 1/2" Norn. Strt. Stop	35 lbs.
SWC-80S	1/2" O.D. x 1/2" Norn. Strt. Stop	37 lbs.

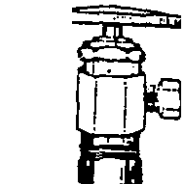

Compression Inlet

C40	3/8" O.D. x 1/2" Norn. Angle Stop	36 lbs.
C60	3/8" O.D. x 1/2" Norn. Angle Stop	36 lbs.
C70	1/2" O.D. x 1/2" Norn. Angle Stop	37 lbs.
CSO	1/2" O.D. x 1/2" Norn. Angle Stop	37 lbs.



Compression Inlet

C6DS,	3/8" O.D. x 1/2" Norn. Strt. Stop	45 lbs.
CSOS	1/2" O.D. x 1/2" Norn. Strt. Stop	38 lbs.
C66S	1/2" O.D. x 3/8" O.D. Comp. Strt. Stop	36 lbs.

Component valves are individually boxed, 6 per package, 72 per master carton.

**db** Dearborn™  
Brass

## Specifications

### DESCRIPTION

- P-trap, 1-1/4" - 17 gauge.
- Includes: (1) low pattern steel flange, (1) regular quarter bend, (1) regular short "J", (2) J.D. rubber washers. (2) zinc die cast nuts.
- Chrome-plated,

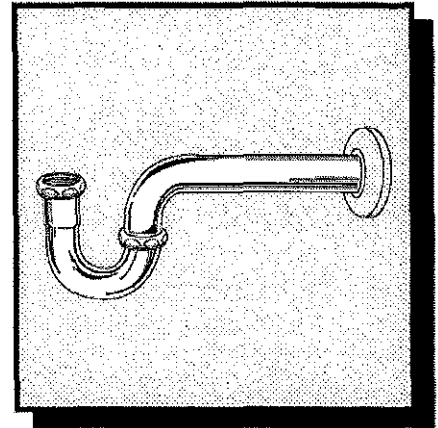

**P-TRAP**  
701-1

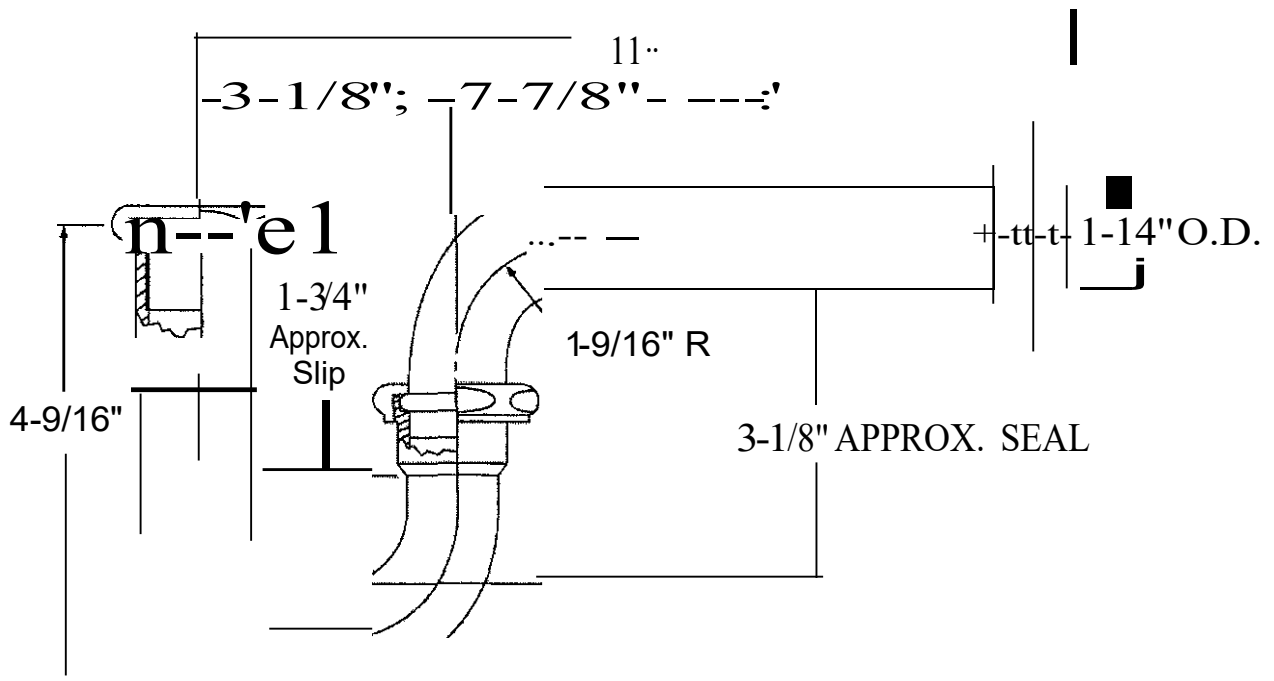

DESCRIPTION

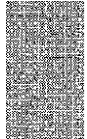

- P-trap, 1-1/2" - 17 gauge,
- Includes: (1) regular pattern steel flange, (1) regular quarter bend, (1) regular short "J", (2) rubber union washers, (2) zinc die cast nuts,
- Chrome-plated,

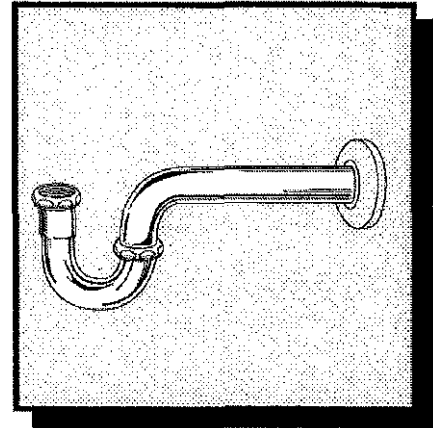

P-TRAP  
704-1

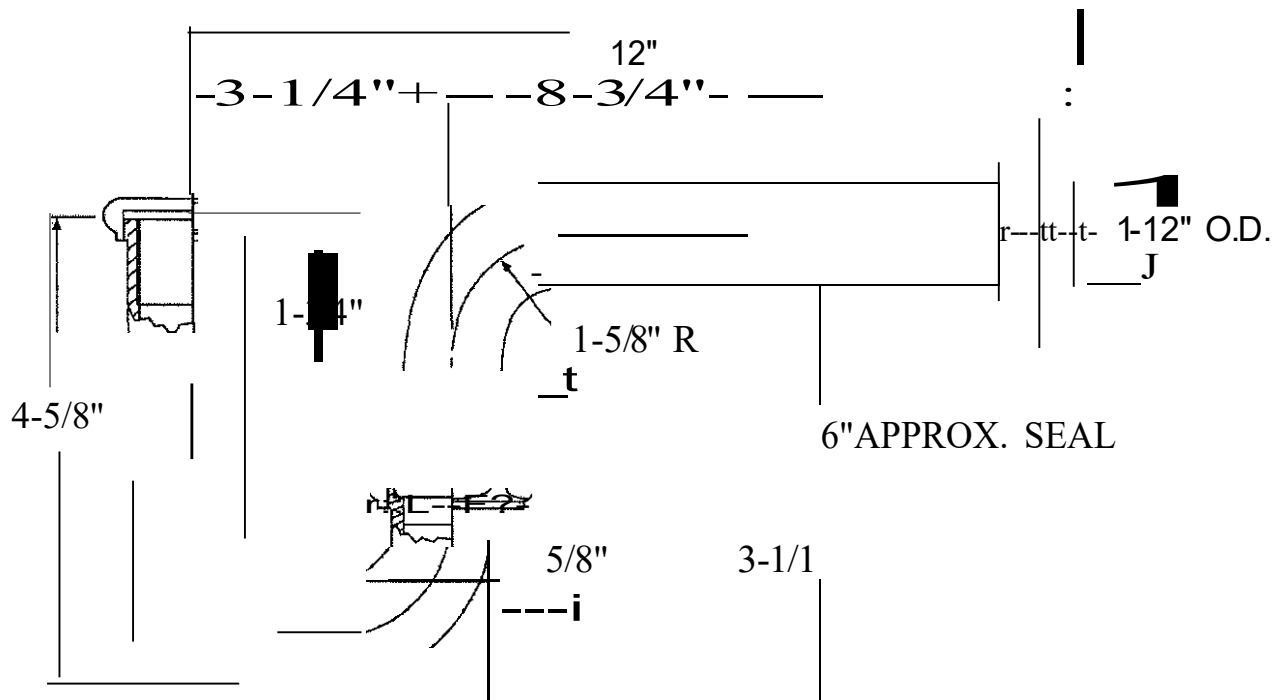

1-800-527-8443 (Toll Free)  
1-800-482-8114 (side Texas)

# PRODUCT INFORMATION SHEET

# K

*RECEIVED*

~~THE KEENEY MANUFACTURING COMPANY~~

# SEMI-CAST TRAP

5303PC

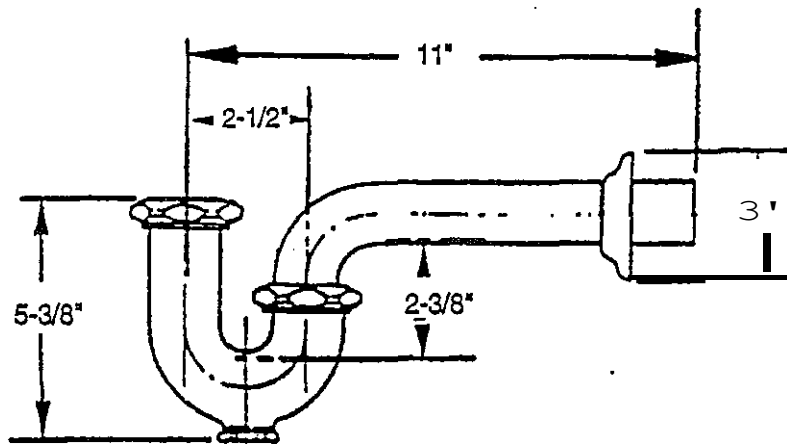

## FEATURES:

- 1-1/4<sup>11</sup> x 1-1/4<sup>11</sup>
- 17 Gauge
- With Cleanout
- Polished Chrome
- Brass Nuts



**WASTE ARMS - SINK TAILPIECES**

PartNum.	Item Description	UPCI 046224 +	Ctn Qty	Ctn Ylt	UeM
<b>WASTE ARMS DIRECT CONNECT {112" .CONTINUED</b>					
542ARB	7" 17GA ROUGH BRASS· BULK PACKED	933236	25	13 lbs.	
542ASN	7" 17GA SATIN· BULK PACKED	933250	25	13 lbs.	
543ARB	9 1/2" 17GA ROUGH BRASS· BULK PACKED	723905	25	15 lbs.	
543ASN	9 1/2" 17GA SATIN· BULK PACKED	933304	25	15 lbs.	
544ARB	11 1/2" 17GA ROUGH BRASS· BULK PACKED	933373	25	18 lbs.	
544ASN	11 1/2" 17GA SATIN· BULK PACKED	933380	25	18 lbs.	
546ARB	15" 17GA ROUGH BRASS· BULK PACKED	933441	25	20 lbs.	
546ASN	15" 17GA SATIN· BULK PACKED	933472	25	20 lbs.	
547ARB	20" 17GA ROUGH BRASS - BULK PACKED	711773	25	25 lbs.	
547ASN	20" 17GA SATIN· BULK PACKED	933625	25	25 lbs.	
548ARB	24" 17GA ROUGH BRASS BULK PACKED	933687	25	33 lbs.	
548ASN	24" 17GA SATIN· BULK PACKED	933700	25	33 lbs.	

**SINK TAILPIECES 1 1/4"**

160PC	4" 22GA CHROME	92099 1	24	2 lbs.
161PC	6" 22GA CHROME	92100 4	24	3 lbs.
162PC	8" 22GA CHROME	92103 5	24	4 lbs.
118PC	12" 22GA CHROME	72391 2	24	7 lbs.

**SINK TAILPIECES 1 1/2"**

110RB	4" 22GA ROUGH BRASS	91799 1	48	6 lbs.
110PC	4" 22GA CHROME	91796 0	48	6 lbs.
111RB	6" 22GA ROUGH BRASS	91806 6	24	5 lbs.
111PC	6" 22GA CHROME	91803 5	24	5 lbs.
112RB	8" 22GA ROUGH BRASS	91812 7	24	6 lbs.
112PC	8" 22GA CHROME	91808 0	24	6 lbs.
113RB	10" 22GA ROUGH BRASS	91821 9	24	8 lbs.
113PC	10" 22GA CHROME	91819 6	24	8 lbs.
114RB	12" 22GA ROUGH BRASS	91826 4	24	9 lbs.
114PC	12" 22GA CHROME	91822 6	24	9 lbs.
120RB	18" 22GA ROUGH BRASS	91878 3	24	14 lbs.
120PC	18" 22GA CHROME	91877 6	24	14 lbs.
130PC	24" 22GA CHROME	92002 1	24	17 lbs.
210RB	4" 20GA ROUGH BRASS	92292 6	48	9 lbs.
V10PC	4" 20GA CHROME	2289 6	48	9 lbs.
211RB			24	6 lbs.
211PC	6" 20GA CHROME	92294 0	24	8 lbs.
212RB	8" 20GA ROUGH BRASS	92302 2	24	9 lbs.
212PC	8" 20GA CHROME	92300 8	24	9 lbs.
214RB	12" 20GA ROUGH BRASS	92312 1	24	13 lbs.
214PC	12" 20GA CHROME	92309 1	24	13 lbs.
220RB	18" 20GA ROUGH BRASS	92322 0	24	20 lbs.
220PC	18" 20GA CHROME	92320 6	24	20 lbs.



#### Features

- 12" (30.5 cm) rough-in
- Round front
- 1.6 gpf (6 /pf)
- **Ingenium™ flushing system**
- Combination toilet
- Includes polished chrome trip lever
- Less seat and supply
- With Insuliner® insulated tank lining (-U)
- With tank cover locks (-T)
- Z' (5.1 cm) glazed trapway
- 10-1/2" (26.7 cm) x 8-7/8" (22.5 cm) water area
- With right-hand trip lever (-RA)
- With bedpan lugs (-L)
- With Insuliner® insulated tank lining

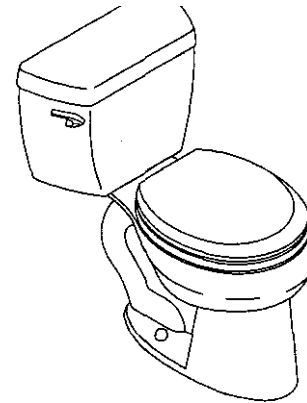

#### Codes/Standards Applicable

Specified model meets or exceeds the following:

- ASME A112.19.6
- ASME A 112.19.2
- Energy Policy Act of 1992 (EPACT)
- IAPMOIUPC
- CSA 845

#### Colors/Finishes

- 0: White
- Other: Refer to Price Book for additional colors/finishes

#### Accessories:

- 0: White
- CP: Polished Chrome
- PB: Polished Brass
- Other: Refer to Price Book for additional colors/finishes

#### Specified Model

Model	Description	Colors/Finishes	
K-3423	Round front bowl toilet (left-hand trip lever)	0 0 White	D Other
K-3423-T	Toilet with tank cover locks (left-hand trip lever)	0 0 White	D Other
K-3423-U	Toilet with Insuliner tank (left-hand trip lever)	0 0 White	D Other
K-3423-UT	Toilet with Insuliner tank & tank cover locks (LH trip lever)	0 0 White	O Other
K-4277-L & K-4620	Toilet with bed pan lugs (left-hand trip lever)	D 0 White	D Other
K-3423-RA	Round front bowl toilet (right-hand trip lever)	0 0 White	D Other
K-3423-TR	Toilet with tank cover locks (right-hand trip lever)	0 0 White	D Other
K-3423-UR	Toilet with Insuliner tank (right-hand trip lever)	0 0 White	D Other
K-4277-L & K-4620-RA	Toilet with bed pan lugs (right-hand trip lever)	0 0 White	O Other_____

#### Product Specification:

The round front combination elongated toilet compact toilet shall be 12" (30.5 cm) rough-in. Toilet shall be made of vitreous china. Toilet shall have 10-1/2" (26.7 cm) x 8-7/8" (22.5 cm) water area. Toilet shall be 1.6 gpf (6 lpf) with Ingenium™ flushing system. Toilet shall have a 2" (5.1 cm) glazed trapway. Toilet shall include polished chrome trip lever. Toilet shall be less seat and supply. Toilet shall have right-hand trip lever. Toilet shall have bed pan lugs (-L). Toilet shall have Insuliner® insulated tank lining (-U). Toilet shall have tank cover locks (-T). Toilet shall be Kohler Model K-3423-\_\_\_\_\_

# WELLWORTH™

Recommended Accessories			
K-4658	Breviar™ seat with cover	<input type="checkbox"/> White	<input type="checkbox"/> Other
K-4663	French Curven seat with cover	<input type="checkbox"/> White	<input type="checkbox"/> Other
K-4686	Primary™ open front seat	<input type="checkbox"/> White	<input type="checkbox"/> Other
K-7637	Angle supply with stop	<input type="checkbox"/> GP	<input type="checkbox"/> PS <input type="checkbox"/> Other _____
Optional Accessories			
K-9404-L	Trip lever, left-hand (non-GP)	<input type="checkbox"/> PS	<input type="checkbox"/> Other
K-9404-R	Trip lever, right-hand (non-GP)	<input type="checkbox"/> PB	<input type="checkbox"/> Other _____

## Installation Notes

Install this product according to the installation guide.

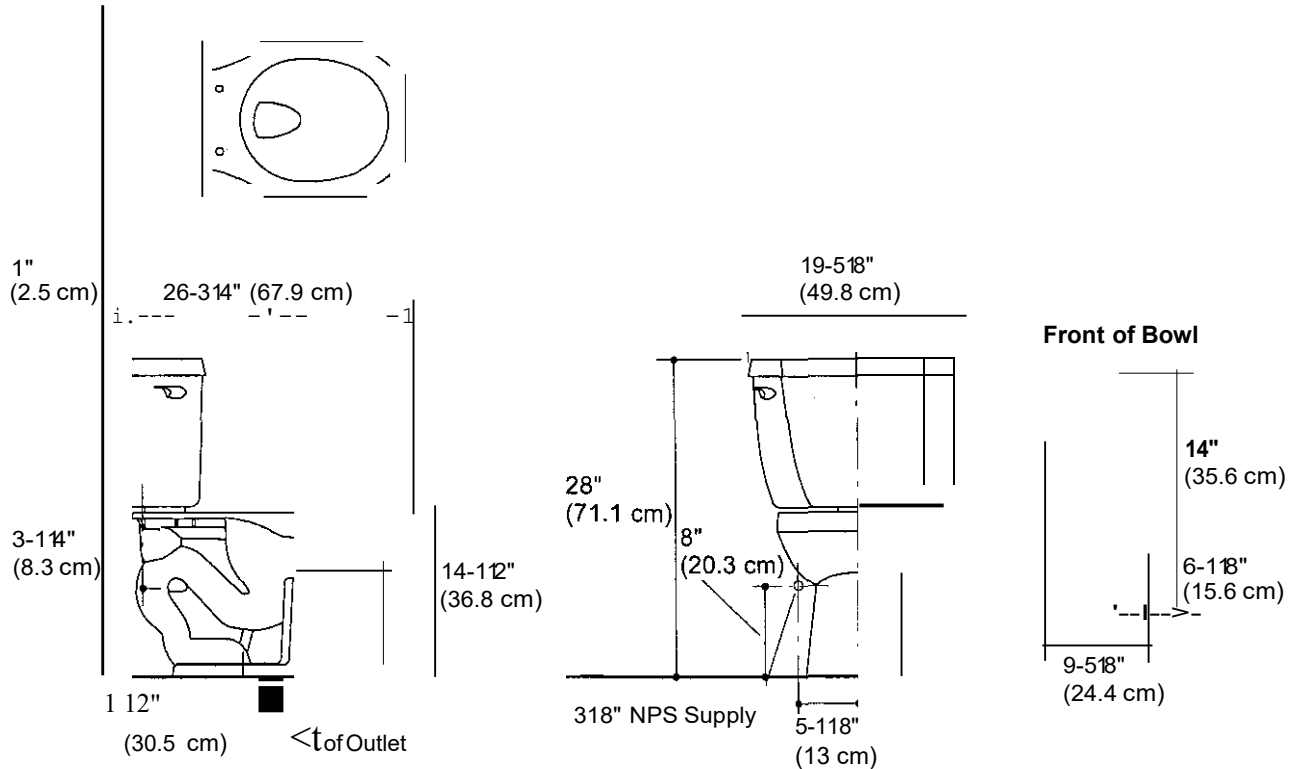

## Product Diagram

# KOHLER.

## HIGHLINE

### TOILET

# K-3427

| ADA |

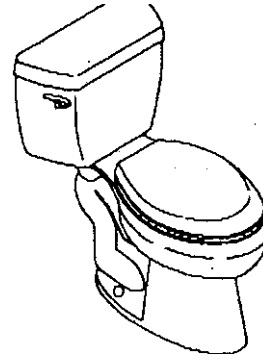

HANDICAP  
BASE

### FEATURES

- Gravity flush
- 12" rough-in
- Vitreous china
- Elongated bowl
- 1.6gpf
- Includes polished chrome trip lever
- Combination toilet
- 16-1/2" high bowl is ADA compliant
- 2-glazed trapway
- Less seat and supply
- With right-hand trip lever (-RAJ)
- With bidpan lugs (-L)
- With Insuliner, insulated tank lining (-U)
- With tank cover locks (-T)

### CODES/STANDARDS APPLICABLE

Specified model meets or exceeds the following:

- ADA
- ASME/ANSI A 112.19.2M
- ASME/ANSI A 112.19.6M
- CASO/ANSI A 117.1
- Energy Policy Act of 1992 (EPACTJ)
- Canadian Standards Association (CSA)
- IAPMO/IPC
- States of Massachusetts, New York, & Texas
- City of Los Angeles, CA

### COLORS/FINISHES

- D White
  - Other Refer to Fixtures Price Book for additional colors
- Accessories:
- O White
  - CP Polished Chrome
  - PB Polished Brass
  - Other Refer to Fixtures Price Book for additional colors

### SPECIFIED MODEL:

Model	Description	Color/Finish	
K-3427	Elongated bowl toilet	DO White	DOiher
K-3427-T	Toilet with tank cover locks	DO White	DOiher
K-3427-U	Toilet with Insuliner tank	DO WMe	DO!her
K-3427-UT	Toilet with tank cover locks and insuliner tank	DO White	DOther _____
K-4274-L & K-4620	Toilet with bid pan lugs (left-hand trip lever)	DO White	OO!her
K-3427-RA	Elongated bowl toilet (right-hand trip lever)	DO White	DQ!her
K-3427-TR	Toilet With tank cover locks (right-hand trip lever)	DO White	DQ!her
K-3427-UR	Toilet with Insuliner tank (right-hand trip lever)	DO White	DOiher
K-4274-L & K-462G-RA	Toilet with bid pan lugs (right-hand trip lever)	DO White	OOiher
Recommended Accessories			
K-4852	Lustra seat with cover	DO White	OO!her _____
K-4652-A	Lustra seat with cover (includes anti-microbial agent)	DO White	

More Recommended & Optional Accessories on Page 2

### PRODUCT SPECIFICATION:

The elongated combination toilet shall be 12" rough in. Toilet shall be made of vitreous china. Toilet shall be 1.6 gpf; Toilet shall include polished chrome trip lever. Toilet shall be ADA compliant with 16-1/2" high bowl. Toilet shall have 2" glazed trapway. Toilet shall be less seat and supply. Toilet shall have right-hand trip lever (-RA). Toilet shall have Insuliner insulated tank lining (-U). Toilet shall have tank cover locks. Toilet shall be Kohler Model K-3427-

We reserve the right to make revisions without notice in the design of fixtures or in packaging unless this right has specifically been waived at the time the order is accepted.

# HIGHLINE.

Recommended Accessories (cont.)			
K-4650	Lustre - open front seat	00 White	Other: _____
K-4670-C	Lustre - open front seat	00 White	Other: _____
K-7637	Angle supply with stop	DCP IDPB	Other: _____
Optional Accessories			
K-9404-L	Trip lever (non CP)	DPB	Other: _____

## PRODUCT INFORMATION

Fixture;	
Configuration	2-piece, elongated
Gallons per flush	1.6
Passageway	2
Water depth from rim	6"
Seat post hole centers	5-1/2"
Included Components:	
Bowl	K-4274
Tank	K-4620
Tank cover	64635
Trip lever	K-9404

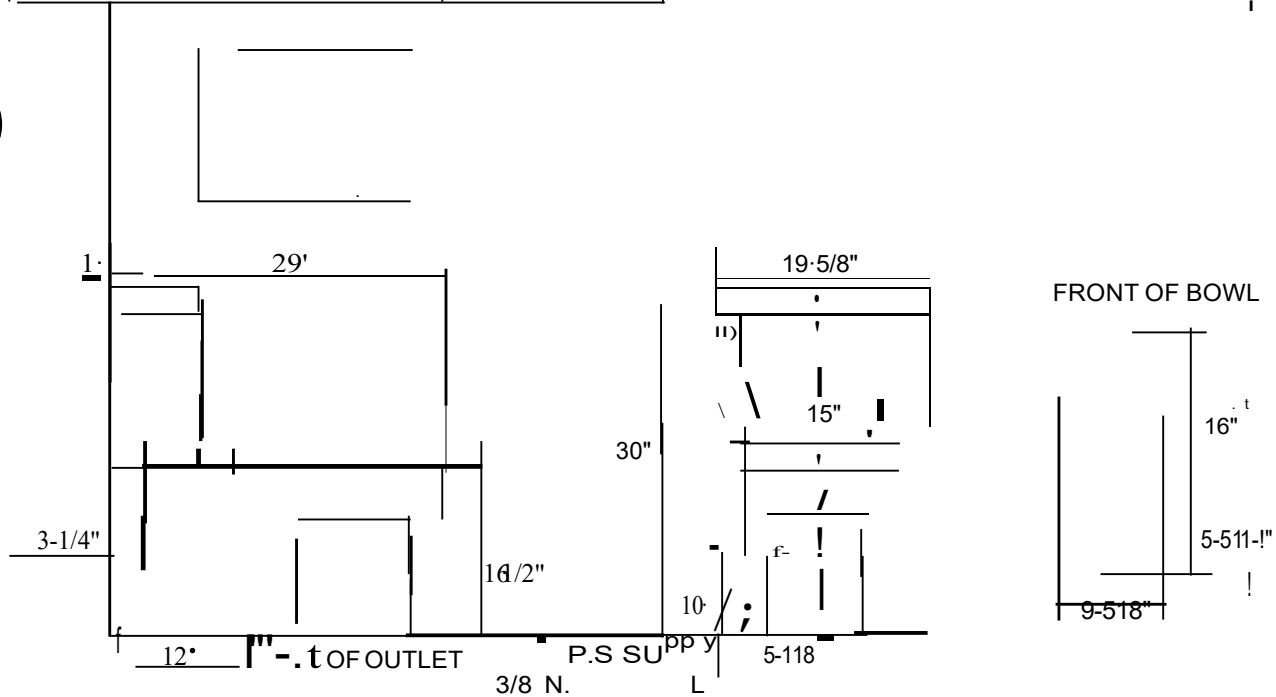

116

## PRODUCT DIAGRAM

**MADERA™ ELONGATED 10" ROUGH**

- Vitreous china
- Low-consumption (6.0 Lpf/1.6 gpf)
- 10" roughing-in
- Elongated bowl
- Direct-fed siphon jet action
- Fully glazed 2" ballpass trapway
- 11" x 13" water surface area
- 1-1/2" top spud
- 2 bolt caps
- 100% factory flush tested

2234.015 Top spud

2234.137 Top spud with slotted rim for bedpan holding (white only)

**Nominal Dimensions:**

768 x 381 x 359mm  
(30-1/4" x 15" x 14-1/8")

Recommended working pressure'-between  
25 psi at valve when flushing and 80 psi  
static

Fixture only, less seat

**Compliance Certifications -  
Meets or Exceeds the Following Specifications:**  
• ASME A112.19.2M (and 19.5M) for Vitreous

China Fixtures - includes Flush Performance,  
Ball Pass Diameter, Trap Seal Depth and  
all Dimensions

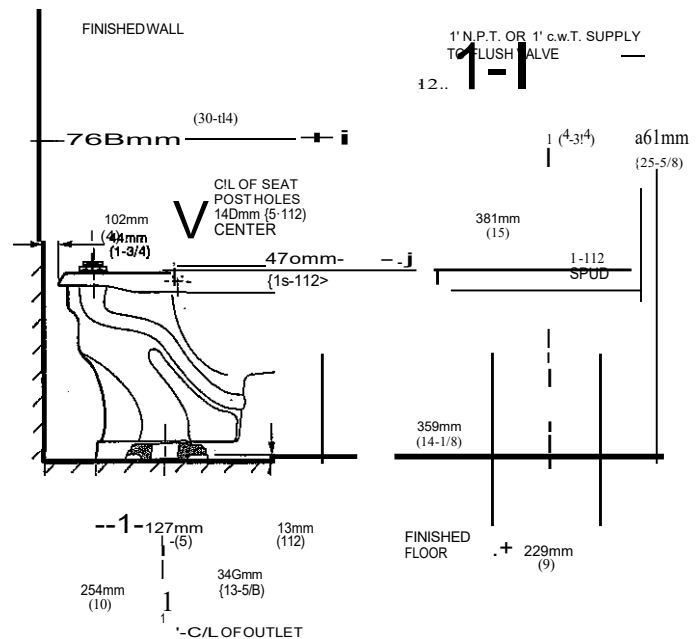

**NOTES:**  
PRODUCT 2234.015 SHOWN, 2234.137 SAME AS EXCEPT WITH SLOTTED RIM FOR BED PAN HOLDING.  
TO COMPLY WITH AREA CODE GOVERNING THE HEIGHT OF VACUUM BREAKER ON FLUSH VALVE, THE PLUMBER MUST VERIFY DIMENSIONS SHOWN FOR SUPPLY ROUGHING.  
FLUSH VALVE NOT INCLUDED AND MUST BE ORDERED SEPARATELY.  
THIS TOILET IS DESIGNED TO ROUGH-IN AT A MINIMUM DIMENSION OF 254MM (10") FROM FINISHED WALL TO C/L OF OUTLET.  
**IMPORTANT:** Dimensions of fixtures are nominal and may vary within the range of tolerances established by ANSI Standard A112.19.2.  
These measurements are subject to change or cancellation. No responsibility is assumed for use of superseded or voided pages.

- To Be Specified**
- Color:  White  Bone  Silver  Black  Shell
  - Seat: Olsonite #95 open front seat less cover
  - Seat: Church #9500C open front seat less cover
  - Alternate Seat:
  - Flush Valve: Sloan Royal #111
  - Alternate Flush Valve:

#### Features

- o Vitreous china
- Elongated bowl
- 1.6 gpf (6 lpf)
- Z' (5.1 cm) glazed trapway
- Ingenium™ flushing system
- Combination toilet
- Includes polished chrome trip lever
- Less seat and supply
- With Insuliner® insulated tank lining (-U)
- With tank cover locks (-T)
- With right-hand trip lever (-RA)
- o With bedpan lugs (-L)

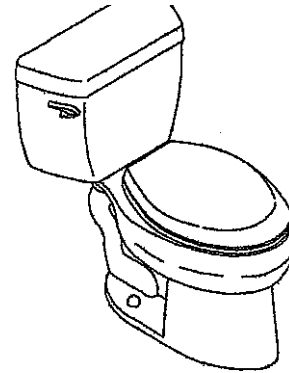

#### Codes/Standards Applicable

Specified model meets or exceeds the following:

- ASME A 112.19.6
- ASME A 112.19.2
- Energy Policy Act of 1992 (EPACT)
- IAPMOIUPC
- CSA B45

#### Colors/Finishes

- O: White
- Other: Refer to Price Book for additional colors/finishes

Accessories:

- O: White
- GP: Polished Chrome
- PB: Polished Brass
- Other: Refer to Price Book for additional colors/finishes

#### Specified Model

Model	Description	Colors/Finishes	
K-3422	Elongated bowl toilet (left-hand trip lever)	O O White	O Other
K-3422-T	Toilet with tank cover locks (left-hand trip lever)	O O White	O Other _____
K-3422-U	Toilet with Insuliner tank (left-hand trip lever)	O O White	O Other
K-3422-UT	Toilet with Insuliner tank and tank cover locks (LH trip lever)	O O White	O Other
K-4276-L & K-4620	Toilet with bed pan lugs (left-hand trip lever)	O O White	O Other _____
K3422-RA	Elongated bowl toilet (right-hand trip lever)	O O White	O Other
K3422-TR	Toilet with tank cover locks (right-hand trip lever)	O O White	O Other
K3422-UR	Toilet with Insuliner tank (right-hand trip lever)	O O White	O Other
K-4276-L & K-4620-RA	Toilet with bed pan lugs (right-hand trip lever)	O O White	O Other _____
Recommended Accessories and Optional Accessories on Page 2			

#### Product Specification:

The elongated combination toilet shall be made of vitreous china. Toilet shall be 1.6 gpf (6 lpf) with Ingenium™ flushing system. Toilet shall have 2" (5.1 cm) glazed trapway. Toilet shall include polished chrome trip lever. Toilet shall be less seat and supply. Toilet shall have right-hand trip lever (-RA). Toilet shall have bed pan lugs (-L). Toilet shall have Insuliner™ insulated tank lining (-I). Toilet shall have cover locks (-T). Toilet shall be Kohler Model K-3422-\_\_\_\_\_.



# KOHLER®

## WELLWORTH COMFORT HEIGHT

### TOILET

**K-3481**  
) ADA )

### FEATURES

- Concealed trapway
- Ingenium™ flushing system
- 1.6gpf (6L) performance comparable to 3.5gpf (13L) models
- 12" (30.5cm) rough-in
- Vitreous china
- 10-1/2" (26.1cm) x 9-1/4" (23.5cm) water area
- Elongated bowl
- Comfort height
- Includes polished chrome trip lever
- Combination toilet
- 16-1/2" (41.9cm) high bowl sADA compliant
- Less seat and supply
- With Insuliner® insulated tank lining (U)



### CODES/STANDARDS APPLICABLE

Specified model meets or exceeds the following:

- ADA
- ◊ ASME/ANSI A 112.19.2M
- CABO/ANSI A117.1
- Energy Policy Act of 1992 (EPACT)
- CSA
- IAPMO/IUPC

### COLORS/FINISHES

- 0 White
- Other Refer to Fixtures Price Book for additional colors

Accessories:

- 0 White
- CP Polished Chrome
- PB Polished Brass
- Other Refer to Fixtures Price Book for additional colors

### SPECIFIED MODEL:

Model	Description	Colors/Finishes	
K-3481	Elongated bowl toilet	DO White	DOther
K-3481-U	Toilet with Insuliner tank	DO White	DOther _____
<b>Recommended Accessories</b>			
K-4652	Lustra™ seat with cover	DO White	DOther _____
K-4652-A	Lustra™ seat with cover (includes anti-microbial agent)	DO White	
K-4650	Lustra™ open front seat	DO White	DOther _____
K-4670.C	Lustra™ open front seat	DO White	DOther _____
K-7637	Angle supply With stop	DCP DPB	DOther _____
<b>Optional Accessories</b>			
K-9404-I.	Trip lever (non-GP)	DPB	DOther _____

### PRODUCT SPECIFICATION:

The elongated combination toilet shall be 12" (30.5cm) rough-in. Toilet shall be made of vitreous china. Toilet shall have concealed trapway. Toilet shall have 10-1/2" (26.7cm) x 9-1/4" (23.5cm) water area. Toilets shall have Kohler Ingenium™ flushing system. Toilet shall be at comfort height Toilet shall be 1.6gpf (6L). Toilet shall include polished chrome trip lever. Toilet shall be AfJA compliant with 16-1/2" (41.9cm) high bowl. Toilet shall be less seat and supply. Toilet shall have Insuliner® insulated tank lining (U). Toilet shall be Kohler Model K-3481.

We reserve the right to make revisions without notice in the design of fixtures or in packaging unless this right has specifically been waived at the time the order is accepted.

Page 1 of 2  
1014444-4-A



# WELLWORTH COMFORT HEIGHT™

## PRODUCT INFORMATION

Fixture:	
Configuration	2-piece, elongated
Water per flush	1.6 gallons (6L)
Passageway	2-1/6" (5.4cm)
Water area	10-1/2" (26.7cm) x 9-1/4" (23.5cm)
Water depth from rim	5-1/2" (14cm)
Seat post hole centers	5-1/2" (14cm)
Included Components:	
Bowl	K-4276
Tank	K-4620
Tank cover	84591
Trip lever	K-9404

Fixture dimensions are nominal and conform to tolerances in ASME Standard A112.19.2M.

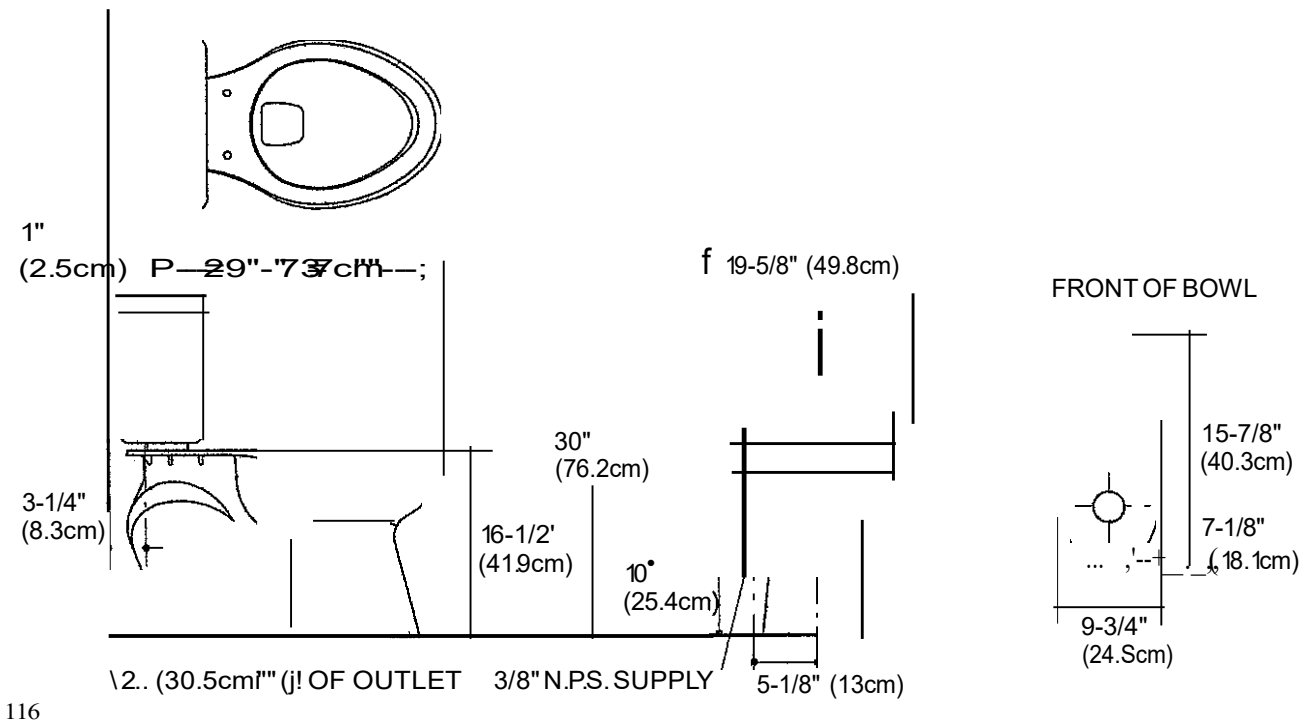

## PRODUCT DIAGRAM

**tMt S!Mttlaid |**  
**BARRIER FREE**

**AFWALL™ t:LONGATE:D**  
**...FLUSfl,VALVE TOILET**  
 VITREOUS CHINA

**AFWALL™ ELONGATED TOILET**

- Vitreous china
- Low-consumption (6.0 Lpf/1.6 gpf)
- Wall-mounted elongated bowl
- Fully glazed trapway
- Condensation channel
- Direct-fed siphon jet action
- 1-1/2" inlet spud
- 2" baflpass trapway
- 10" x 12" water surface area
- 100% factory flush tested

((J· 225703. +P u<leffi.c +; :!

- 2256.194 Top spud with slotted rim for bedpan holding (White only)
- 2258.125 Back spud ·
- 2254.127 Back spud with slotted rim for bedpan holding (White only)

Recommended working pressure--between 30 pSi at valve when flushing and 80 psi static

Nominal Dimensions:  
 635 x 375 x 381mm (25" x 14-3/4" x 15")

Fixture only, less seat and bolt caps

Compliance Certifications •  
 Meets or Exceeds the Following Specifications:  
 • ASME A112.19.2M (and 19.BM) for Vitreous China Fixtures - includes Flush Performance, Ball Pass Diameter, Trap Seal Depth and all Dimensions

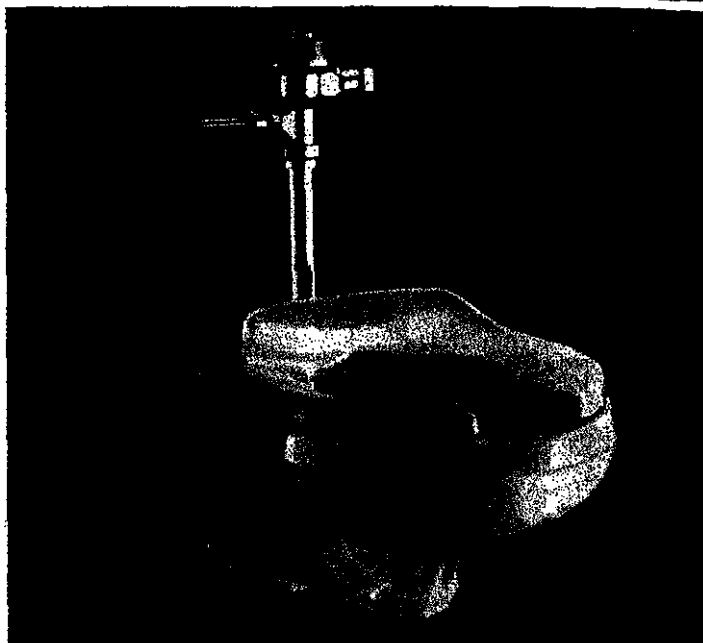

NOTE: Roughing-in information shown on reverse side of page

**To Be Specified**

- Color:  White.  Bone  Silver  Shell  Black
- Seat: Olsonite #95 open front seat less cover
- Seat: Church #9500C open front seat less cover
- Alternate Seat:
- Flush Valve: Sloan Royal #111 (Top Spud)  
 Sloan Royal #144-1.5 (Back Spud)
- Alternate Flush Valve:
- Carrier Fitting (by others):

•When installed so top of seat is 432 to 483mm (17" to 19") from the finished floor.  
 MEETS THE AMERICAN DISABILITIES ACT GUIDELINES AND ANSI A117.1 REQUIREMENTS FOR ACCESSIBLE AND USEABLE BUILDING FACILITIES. CHECK LOCAL CODES.

. SPS2254/2256/2257/2258

COM/INS-001

LJ11r e 1

roNTI't t/V f.Vt7I( LeO hJ.TEtC.

DESCRIPTION

# PF8AM

## SANDSTONE

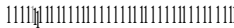

403606

MODEL

**PF8AM**



UPC



0 92026 13527 9

PROD

**503027**

S/N

**0430571464**



MACTCS ..... OASIS CORPORATION

265 N. HAMILTON RD. COLUMBUS, OHIO 43213 U.S.A.



### CHLORINE, TASTE & ODOR, and LEAD & CYST REDUCTION

033879-001

Service Life	1 Year / 1500 Gallons	(5670 Liters)
Maximum Flow	.50 GPM	(1.9 LPM)
Maximum Pressure	125 PSIG	(8.6 bar)
Maximum Temperature	100 F	(38 C)
Minimum Temperature	35 F	(2 C)

**NOTES:**

- ✓ Do not use where water is microbiologically unsafe or of unknown quality without adequate disinfection before or after unit.
  - ✓ Install in cold water applications only.
- A. Unscrew old cartridge from head.
  - B. Screw in new cartridge until lightly seated. **DO NOT** overtighten.
  - C. Check for leaks. If leaks occur, repeat Steps 1 through 3. If leaks persist, discontinue use and call your supporting dealer.
  - D. Flush 4 gallons of water through filter before use.
  - E. Install and dispose of in compliance with local and state regulations.

*FILTER*

Oasis® and  are Registered Trademarks of Oasis Corporation.

OASIS Corporation  
265 North Hamilton Road  
Columbus, Ohio 43213  
800.64.OASIS (800.646.2747)  
OasisWaterCoolers.com

Dayton" Double Bowl  
Models D-23321 and D-23322

# DAYTON

## SPECIFICATIONS

### GENERAL

Sink bowls are seamlessly drawn of #22 gauge nickel-bearing stainless steel.

### DESIGN FEATURES

Bowl Depths: 6-1/2".

Coved Corners: Interior vertical and horizontal corners are rounded to a minimum of 2-3/4" radii.

Faucet Deck: Raised.

Finish: Exposed surfaces are polished to a satin finish with highshine bowl radius.

Underside: As described below.

Self-rimming: Sink is furnished with appropriate number of clamps to provide a secure, watertight installation.

### OTHER

Drain opening: 3-1/2".

Faucet Holes: 3 or 4 holes as indicated, 4N center to center.

Note: Unless otherwise specified, sink is furnished with 4 faucet holes as shown.

ANSI Standard 112.19.3M compliant.

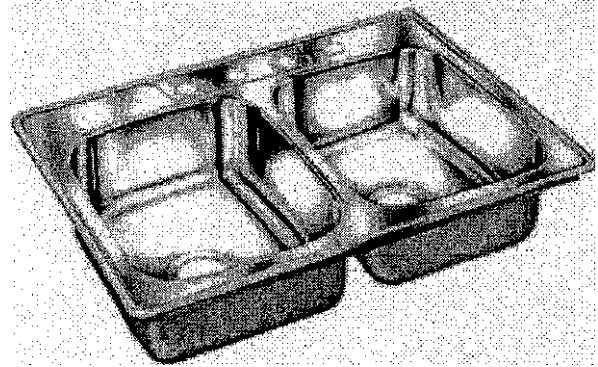

Model 0-23322-4 Shown

Model	0-11	In&ldt Bowl	Flange With	Cutout In Countertop	Number of Fuel Openings	Ship. Wt.
		C O E	F G	1. Rldlu1		
0.23321	33 21 1/2	14 15 1/2	4 1/2	32 1/2	4	12 1/2
D-23322	33 22	14 15 1/2	4 1/2	32 1/2	3 4	12 1/2
06-221	33 21 1/2	14 15 1/2	4 1/2	32 1/2	3 4	66
06-2.3322	33 22	14 15 1/2	4 1/2	32 1/2	3	67
051.23321	J3 21 1/2	14 15 1/2	4 1/2	32 1/2	3 014	60S
050-23321	33 22	14 15 1/2	4 1/2	32 1/2	3 014	60S

6- Pre-sinks are lifted into shipping carton. Sink bowls are 50% undeadened on bottom only. OW. Prelb sinks are nested 50 Sinks per shipping carton. Sink bowls are 50% undeadened on bottom only.

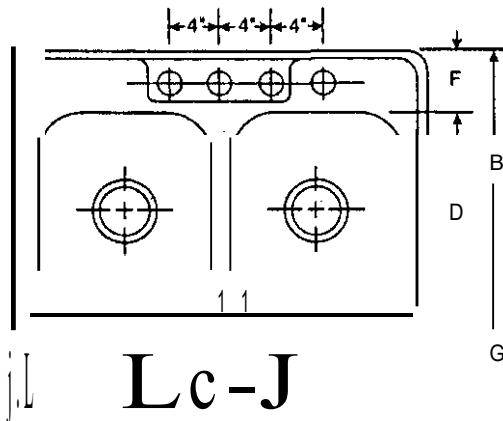

C=Equals Depth

Model D-23322-4 rrus1rated

ALL DIMENSIONS IN INCHES. TO CONVERT TO MILLIMETERS MULTIPLY BY 25.4.

In filing with our Policy of continuing product improvement, Elkay reserves the right to change product specifications without notice.

This specification describes an Elkay product with design, quality and functional benefits. When making a comparison of other products' offerings, be certain these features are not overlooked.

Elkay Manufacturing Company

www.elkay.com

2222 Camden Court  
Oak Brook, IL 60523

Printed in U.S.A.  
©1999 Elkay Mfg. Co.

(Rev. 1/99) 2-14C

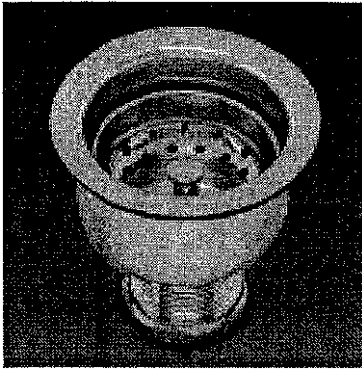

**SNAP-n-LOC. MODEL SS-306**

The most innovative basket strainer in history. The basket seals to the body through a ball bearing in the post creating a positive leakproof seal. Deep cup body and basket are 300 series stainless steel and both are buffed, creating a high polish finish. Hand knob and post are chrome plated brass and

the ball bearing is 300 series stainless steel. Zinc nuts are standard. Available with a brass tailnut (SS-306BTN) or brass tailnut and locknut (SS-3068). Fits 3 1/2" to 4" sink openings.

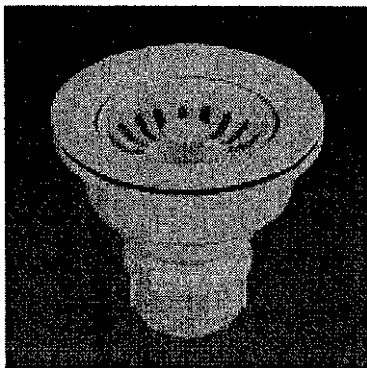
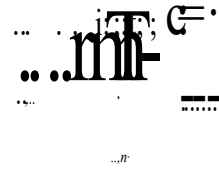
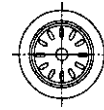

**CELCON. SNAP-n-LDC. MODEL 307**

Jomar's CELCON" SNAP-N-LOC BASKET STRAINER fits all 3 1/2" sink openings. It is dishwasher safe and is guaranteed not to crack, chip or fade.

Snap-N-Loc is easy to install. Available in 5 dynamic colors: White, Brite White, Bone, Biscuit and Linen.

Available in the 2nd Half of 2002.

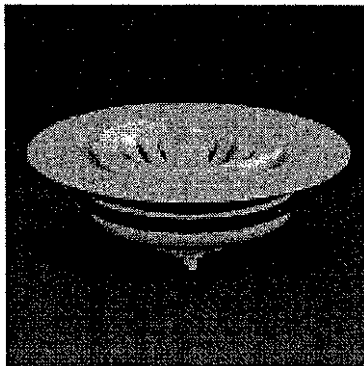
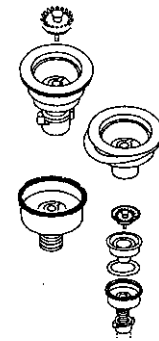



**CELCON. FIT-ALL MODEL DS 311**

Jomar's CELCON• FIT-ALUSINK DISPOSER STRAINER fits inside most existing disposers and strainer flanges. It is dishwasher safe and is guaranteed not to crack, chip or fade.

Available in 5 dynamic colors: White, Brite White, Bone, Biscuit and Linen.

Available in the 2nd Half of 2002.



		
1305-WSHDF	1325-WSHDF	145-wstioF · J 1 6.l

Submitted Model No.: \_\_\_\_\_

Specific Features: \_\_\_\_\_

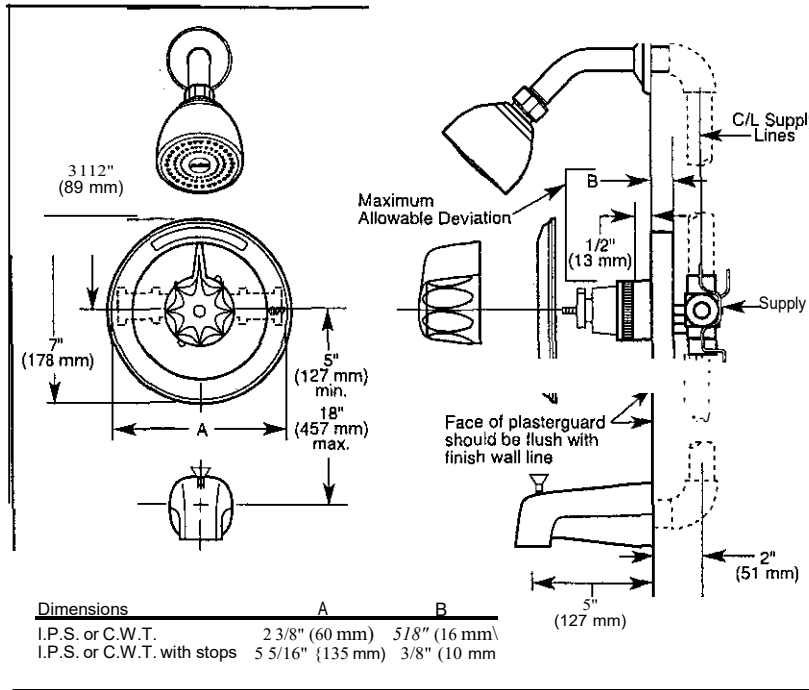

**© DELTA.**  
COMMERCIAL

## BATH MIXING VALVES

- Valve Only (1305 Series)
- Shower Only (1325 Series)
- Tub/Shower (1345 Series)
- Single Handle
- Monitor® with Scald-Guard® Valve
- Pressure Balance
- Temperature Only Controlled with Handle

**C1) c@us**  
LISTED  
UL Listed to US and Canadian  
SBBly Standards D

### COMPLIES WITH:

- ASME A112.18.1
- CSA 8125

**m** indicates ADA compliance to  
LQ.: CABO/ANSIAJ 17.1

- ASSE 1016
- IAPMO Listed
- CSA Certified
- City of L.A. approved

### STANDARD SPECIFICATIONS:

- Pressure balanced single handle bath mixing valve.
- Requires 1 1/2" (38 mm) wall cavity.
- Back-to-back installation capability.
- Solid brass fabricated body.
- Vandal resistant blade handle.
- Monitor4D with ScaldGuard\* valve. Valve accomplishes pressure balancing by using a stainless steel spool and sleeve in a replaceable cartridge. Cartridge utilizes integral check valves to prevent the cross flow of water within the valve. ScaldGuard\* valve reduces the flow of water to .5 gpm / 1.9 L/min within 5 seconds of the complete loss of pressure in the cold water supply line. Outlet water temperature is maintained within +/- 3°F variation with changes in either hot or cold supply of up to 50 percent of the normal supply pressure.
- Temperature only controlled by handle with cold water always coming on first if cartridge is installed correctly.
- Field adjustable to limit handle rotation into hot water zone. Per ASSE 1016.
- 120° maximum handle rotation.
- Screwdriver stops.
- All parts shall be replaceable from front of valve.

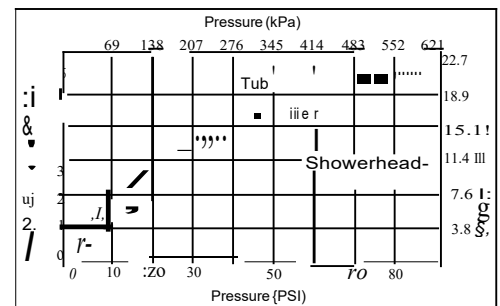

Standard Features	1	2	3	4	5	6	7	8	9	10
Washerless	●	●	●	●	+	●				
Scald-Guard™ Valve	●	●	●	●	●	●				
Back-to-Back Installation									●	●
1/2" LP.S. Inlets and Outlets	●	●	●	●	+					
1/2" CW.T. Sweat Inlets and Outlets	●	●	●	●						●
Replaceable Cartridge	●	●	●	●	+	●				
Adjustable Rotational Limit Stop	●	●	●	●	+	●				
Vandal Resistant Metal Blade Handle	[;S;]		[;S;]	[;S;]						
Screwdriver Stops	●	●	●	●	●	●				
Metal Shower Arm and Flange			●	●	●	●				
Push-Clean™ Showerhead/1 Spray Pattern			●	●	●	●				
Metal Tub Filler with Pull-Up Diverter									●	●
Chrome Finish	●	●	●	+	●	●				

Available Options for Field Conversion:

- Cambridge Brass vandal resistant front mounting wall mount showerhead. Universal 1/2" FIP copper sweat inlet. Non-adjustable 30 spray angle from wall. 2.5 gpm @ 80 psi (9.5Umin @ 552 kPa). Cast brass with cast brass anchor plate. Chrome plated. Order 76262.
- Vandal resistant brass THE EMBRACER® showerhead -five spray patterns 2.5 gpm @80 psi (9.5Umin @552 kPa). Chrome plated. Order RPW66HDF. See installation wrench below.
- Spanner Wrench for RPW66HOF. Order RP13498.
- Shower Arm. Order RP6023.
- Shower Flange. Order RP6025.
- Metallic tub filler with pull-down diverter for 1/2" C.W.T. or 1/2" I.P.S. Order RP17454.
- Non-metallic tub filler with pull-down diverter for 1/2" C.W.T. or 1/2" I.P.S. Order RP17453.
- Non-metallic slip-on tub filler with pull-down diverter for 1/2" C.W.T. Order RP5836.
- Metallic tub filler with pull-up diverter for 1/2" C.W.T. or 1/2" I.P.S. Order RP7533.
- Non-metallic tub filler with pull-up diverter for 1/2" C.W.T. or 1/2" I.P.S. Order RP5834.
- Non-metallic slip-on tub filler with pull-up diverter for 1/2" C.W.T. Order RP19820.
- Bath waste assemblies and bath accessories also available separately.

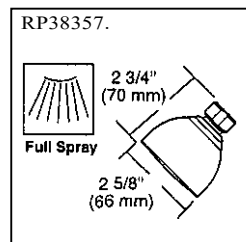
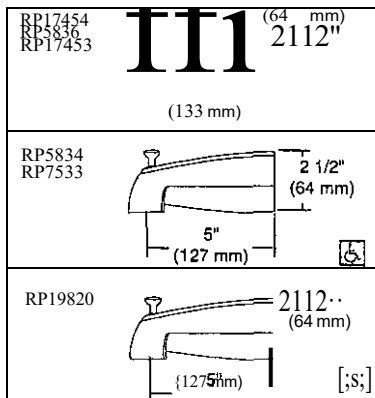

**DELTA.**  
COMMERCIAL

Indianapolis, Indiana 46280  
A Division of Masco Corporation of Indiana  
© 2002 Masco Corporation of Indiana

DSP-1305-HDF Rev. B

## DESCRIPTION

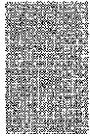

- End Outlet sink waste, 1-1/2" x 16" - 20 Gauge.
- Includes: (1) regular waste arm, (1) tailpiece, T.O.E. 1-1/2" x 3", (3) 1-1/2" die cast nuts, (3) 1-1/2" rubber washers, (1) 1-1/2" tee.
- Chrome-plated.

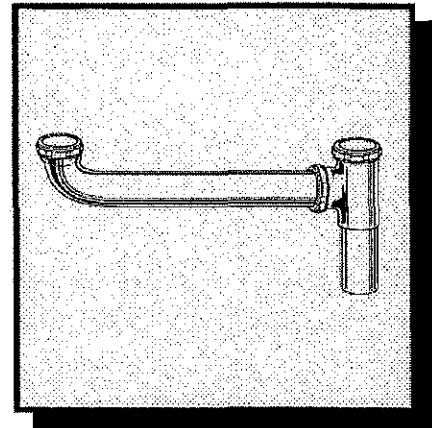

ENDOUTLET  
SINK WASTE  
108A-1

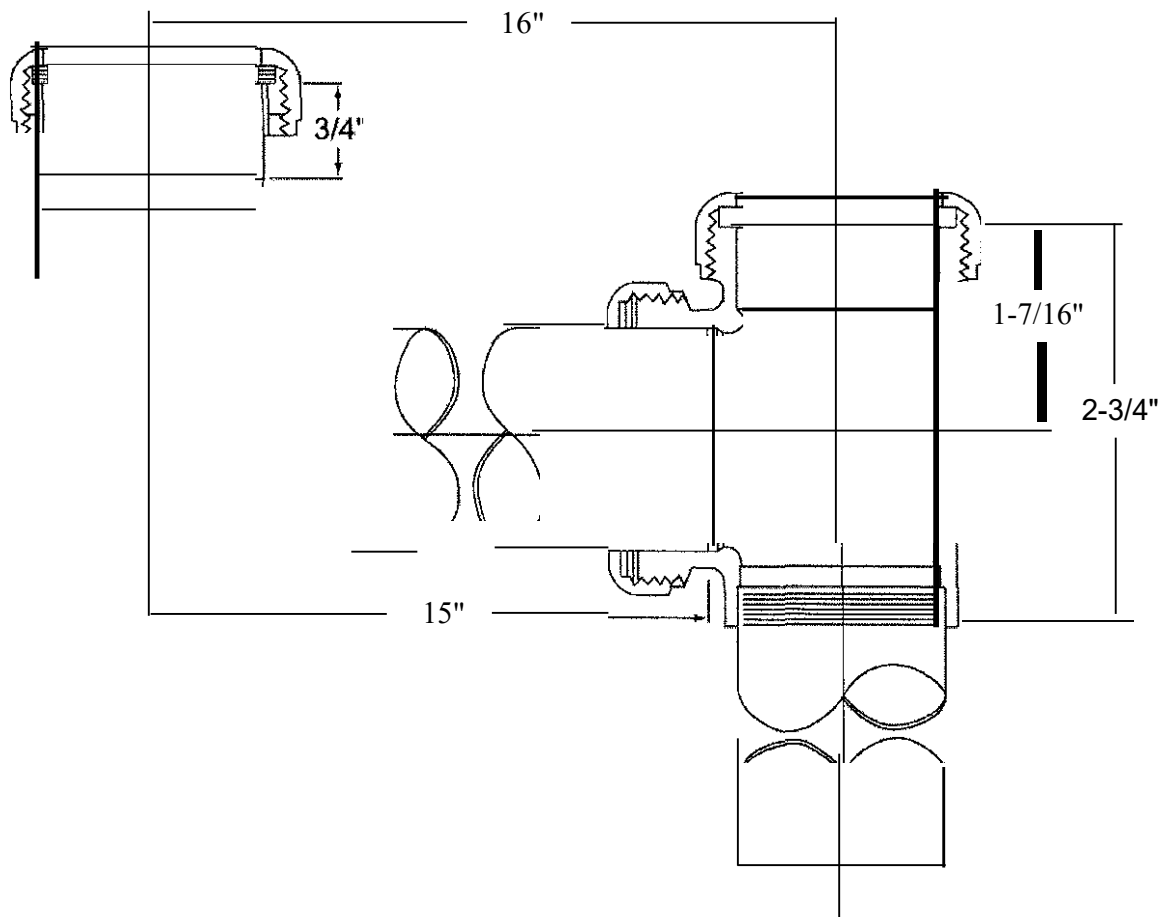



A 5/16/97 MKK JPS RELEASE

8 9/25/02 JPS KAK ADDED CHART

61-6 COMP. NUT

60-6 COMP. SLEEVE

R19 VALVE ASSY

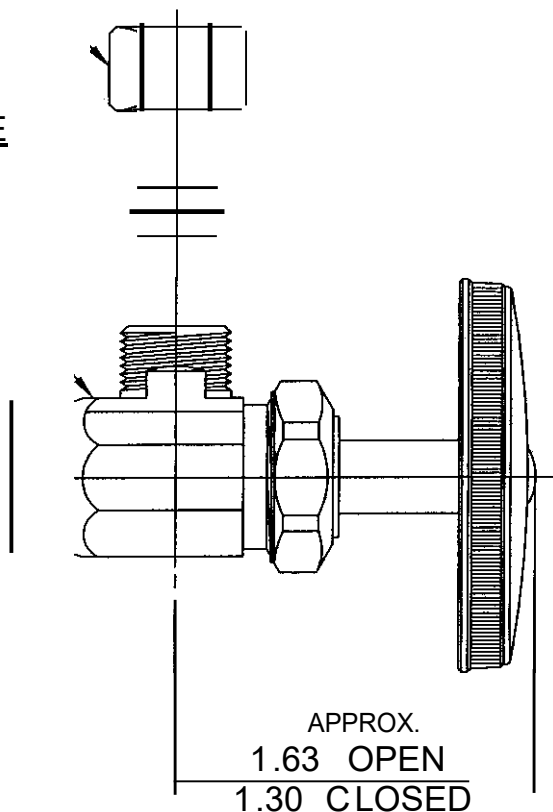

ITEM I.D. ®

CHROME

ROUGH

R19 C

R19 R

APPROX.  
1.63 OPEN  
1.30 CLOSED

<h1>BrassCraft®</h1> <p>NOVI, MICHIGAN A Subsidiary of Mosco Corporation</p>	<b>DESCRIPTION</b> 1/2 NOM. SWEAT x 3/8 O.D. COMP. VALVE ASSEMBLY (SUBMITIAL)		<b>DRAWING NO.</b> VPA0539B
	<b>DRAWN</b> SCHUTIE	<b>DATE:</b> 5/1 5/97	<b>MATERIAL</b>
<b>CHK'D.</b> JPS	<b>DATE'</b> 1	<b>AI-P-D.</b> DATE,	<b>ITEM ID</b> R19 C SEE CHART
ALL GDT PER ANSI STD Y14.5M <b>CLASSIFICATION OF QUALITY LEVELS</b> CLASS SYMBOL KPC (KEY PRODUCT CHARACTERISTICS)	STPC (STANDARD PRODUCT CHARACTERISTICS)	NO. UNL. SS OR OTHERWISE SPECIFIED "TWO PLACE DECIMALS THREE PLACE DECIMALS ANGULARITY	UNL. SCALE (UN TED) B INCH

This print and all data contained hereon is the sole and exclusive property of Brass Craft Mfg. Co., Subsidiary of Masco Corporation, and will not be disclosed to others without the consent of Brass Craft Mfg. Co. This print must be returned to Brass Craft Mfg. Co. if requested.

ITEM I.D.	FINISH
R14 C	CHROME
R14 R	ROUGH

R14 VALVE ASS'Y

60-6 COMP. RING

61-6 COMP. NUT

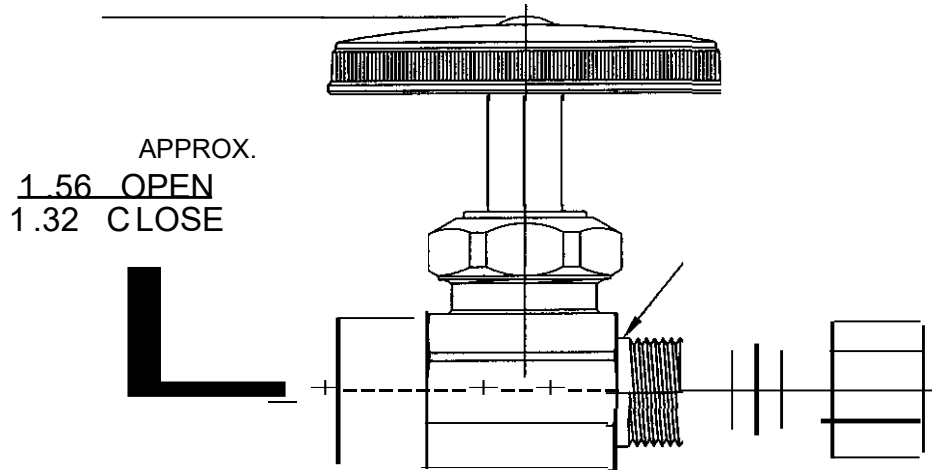

<h1>BrassCraft®</h1> <p>NOVI, MICHIGAN A Subsidiary of Mosco Corporation</p>	<b>DESCRIPTION</b> 1/2 NOM SWT X 3/8 OD COMP STRAIGHT VALVE (SUBMITIAL)		<b>DRAWING NO.</b> VPA0542B
	DRAWN PERNAK 1	DATE: 2/26/2002	MATERIAL
ALL GDT PER ANSI STD Y14.5M <b>CLASSIFICATION OF QUALITY LEVELS</b> CLASS SYMBOL	CHK'D. Klimkie 0	DATE: 1	<b>ITEM ID</b> v nf-1 r\ 1
KPC (KEY PRODUCT CHARACTERISTICS) (> S11'C (STANDARD PRODUCT CHARACTERISTICS) /:: PRODUCT MARKINGS	APP'D. DATE:	NOTE: UNLESS OTHERWISE SPECIFIED - TWO PLACE DECIMALS +/- .010 THREE PLACE DECIMALS +/- .005 ANGULARITY +/- 1" SIZE	UNITS: <b>A</b> INCH FULL B (UNLESS NOTED)

This print and oil data contained hereon is the sole and exclusive property of Brass Craft Mfg. Co., Subsidiary of Masco Corporation, and will not be disclosed to others without the consent of Brass Craft Mfg. Co. This print must be returned to Brass Craft Mfg. Co. if requested.

LET., DATE	PER	BY	CHANGE
------------	-----	----	--------

**B** 5/7/03 WFT MJP REVISED & UPDATED  
**C** 5/28/03 JPS KAK REVISED DESCRIPTION

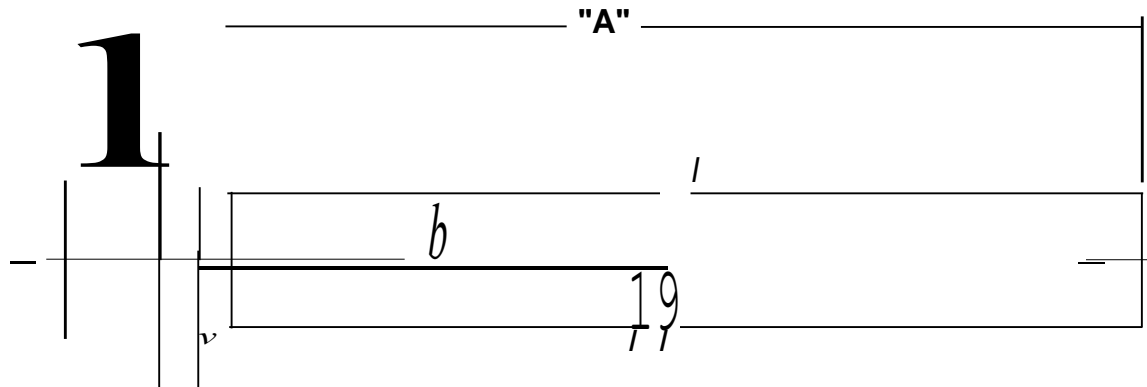

ITEM I.D.	ITEM DESC.	LENGTH 'A'
P1-12A	P1-12A	11.50
P1-15A	P1-15A	14.50
P1-20A	P1-20A	19.50
P1-30A	P1-30A	29.50
P1-36A	P1-36A	35.50

<p><b>Eta ssCraft®</b></p> <p>NOVI, MICHIGAN A Subsidiary of Mosco Corporation</p>	<p>DESCRIPTION          3/8 OD PEX FAUCET RISER TUBE (SUBMITIAL)</p>		<p>DRAWING NO. RPA0083C</p>		
	<p>DRAWN PERNAK</p>	<p>DATE: 5/7/2003</p>	<p>MATERIAL</p>		<p>ITEM DESCRIPTION P1-12A</p>
<p>ALL GOT PER ANSI S1D Y14.5M CLASSIFICATION OF QUALITY LEVELS</p>		<p>CHK'G. Schutte</p>	<p>DATE: 05/28/2003</p>	<p>VOLUME</p>	
<p>CUI55 S&lt;MBJL</p> <p>KEY (KEY PRODUCT CHARACTERISTICS) SIR: (STANDARD PRODUCT CHARACTERISTICS)</p>		<p>APP'D. DATE:</p>		<p>ITEM ID P1-12A</p>	
<p>PRODUCT MARKINGS</p>		<p>NOTE: UNLESS OTHERWISE SPECIFIED          TWO PLACE DECIMALS +/- .010          THREE PLACE DECIMALS +/- .005          ANGULARITY +/- 1"</p>		<p>UNITS INCH</p>	<p>NOTED) REV. FULL C</p>

This print and all data contained hereon is the sole and exclusive property of Brass Craft Mfg. Co. Subsidiary of Mosco Corporation, and will not be disclosed to others without the consent of Brass Craft Mfg. Co. This print must be returned to Brass Craft Mfg. Co. if requested.

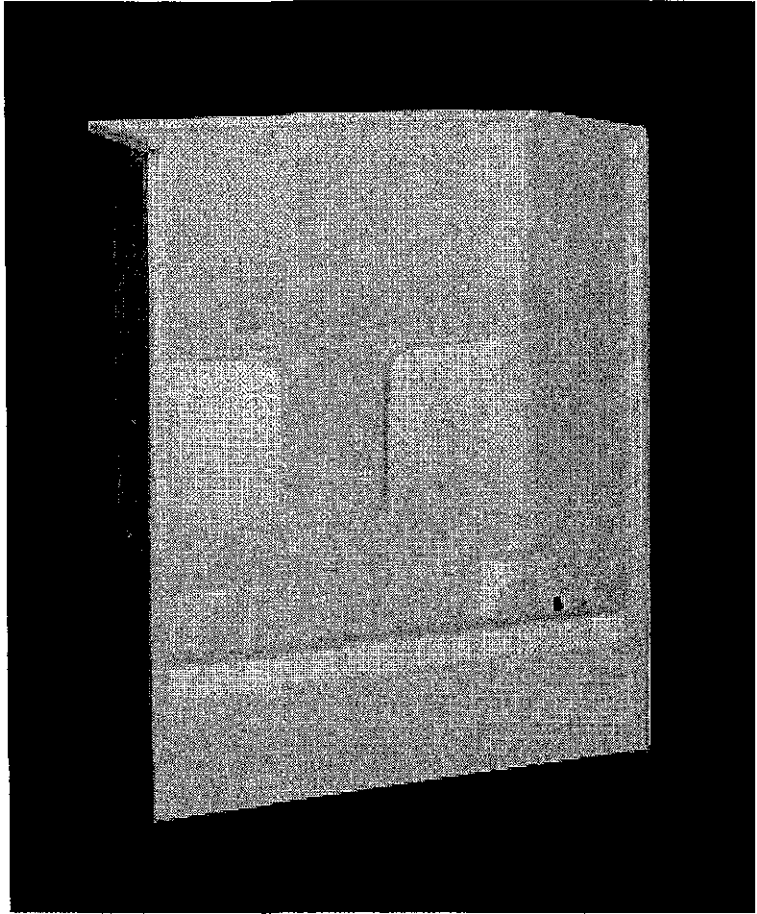
**TUB/SHOWER**

60-INCH MODEL

**CM-60** (Smooth Wall)

Rough-In Dimensions

60" wide x 33" deep x 73-1/2" high

Finished Dimensions

60" wide x 31-1/2" deep x 72" high

Unit Features

- One - Piece Gelcoated Fiberglass
- 2" Dia. Drain/RH or LH (see reverse side for location)
- 2-1/2" Dia. Overflow (see reverse side for location)
- Twin / Elevated Bock Woll Shelves
- Single / Lower Level. Center Soop Ledge with Acrylic Bar
- Textured Floor Pattern
- Balsa Wood "Anti-flex" Floor Construction

Special Notes

- Unit Complies with ANSI Z 124 Series
- Unit Complies with HUD / FHA UM-730 (use of materials)
- Unit Available with Extended Apron (see reverse side for details)

# MAAX" TUB/SHOWER

CM-60

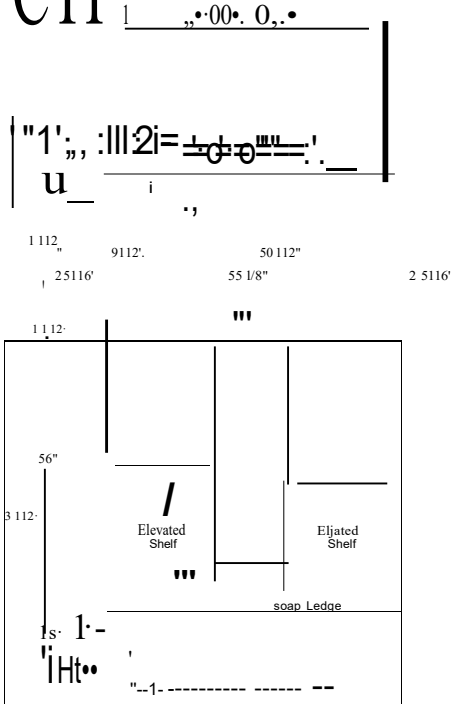

CM-60L (Illustrated)

Sump Bottom: 16" wide x 42" long  
 Sump Depth: 13-1/2" deep  
 Sump Capacity: 36 gallons (to overflow)

Plain Tub/Shower

Order No.: CM - 60R (*RH Drain/Clear Acrylic Bar*)  
 (LH Drain/Clear Acrylic Bar)  
 CM - 60L

60" x 31-1/2", One-Piece, Gelcoated Fiberglass Tub/  
 Shower with 16" apron wall surround, acrylic bar  
 and drain on end indicated.

Tub/Shower Accessories

Order No.: ENC-BPTS601-CH (*Chrome trim*)  
 ENC-BPTS601-PB (*Polished Brass trim*)

Custom fit. no trim tub/shower enclosure with  
 caulkless wall channels, by-pass doors, obscure  
 glass. and EZ Kleen door track.

Order No.: ABFLR (*17-3/4" apron*)

Extended apron height to allow for above the floor  
 plumbing system on unit listed above.

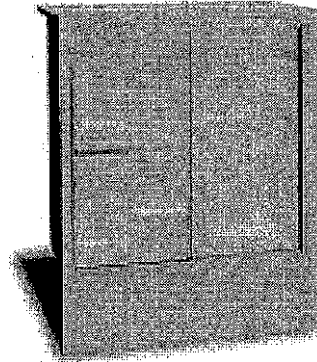

Dimensions shown are maximum. Due to the nature of the materials involved,  
 actual unit dimensions can vary. (tolerances: +/- 3/8 Inch)

# SUBMITAL SHEET

P3A

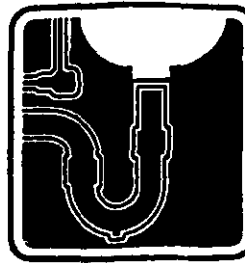

# LAV GUARD™



## UNOERSINK PROTECTIVE PIPE COVERS DESIGN FEATURES

- Universal design fits virtually all lavatory applications
- Antimicrobial vinyl maintains sanitary conditions
- Lock Lid™ on valve stops tampering & allows service
- Cleanout nut cap allows service on trap without disassembly
- Snap-Clip™ fastener is flush, nonabrasive & reusable
- Internal ribs enhance K value & soften impact cushioning

### LAV GUARD Kits Fit:

- All P-trap assemblies, cast brass or tubular - 1 1/2' or 1'1/2'
- All straight tail piece assemblies - 1 1/2' or 1'1/2"
- All standard 5/2 offset wheelchair strainers. (Acc. #105)
- All angle stop valves - handled or keyed type 3/8" or 1/2".
- NOTE: LAV GUARD Kits will not fit Schedule 40 plastic P-traps

Models Available: White or Grey  
Select model and color.

Model #99 O white D gre  
One angle valve and supply cover only

Model #100 D white D gre  
One P trap cover only.

Model #101 O white D gre  
One P-trap cover, one angle valve and supply cover.

Model #102 O white D gre  
One P trap cover, two angle valve and supply covers.

Model #103 O white D gre  
One P trap cover, two angle valve and supply covers, one offset tailpiece wheelchair strainer cover. (Acc. #105)

Accessory #105 O white D gre  
One offset tailpiece wheelchair strainer cover only.

Approved By: \_\_\_\_\_

# LIJ TRUEBRO

MAKING AMERICA ACCESSIBLE

TRUEBRO, Inc.  
7 Main Street • Ellington, CT 06029  
(203) 875-2868 • 1-800-340-5969  
Fax: (203) 872-0300

### PRODUCT DESCRIPTION

LAV GUARD waste and supply piping covers satisfy all ADA compliance requirements with its unique and universal design, allowing for easy installation over virtually all tubular and cast brass P-trap assemblies, as well as angle valve <1nd supply tube assemblies, regardless of their geometry or rotational offset. Smooth, flush Snap Clip™ fasteners firmly secure piping covers in place.

### SAMPLE SPECIFICATIONS

Handicap lavatory P-trap and angle valve assemblies shall be covered with the soft, antimicrobial, LAV GUARD, piping cover manufactured by TRUEBRO, Inc. Model # \_\_\_\_\_  
Accessory # \_\_\_\_\_, color \_\_\_\_\_ (white or grey).  
Piping cover shall be secured with Snap Clip™ flush mounted fasteners. Angle stop valve shall be secured with locking lid access cover. Cover shall be non-yellowing and fire retardant.

12" supply tube cover is very flexible to fit any bend in supply tube.

Lock Lid™ offers tamper resistance and yet allows service

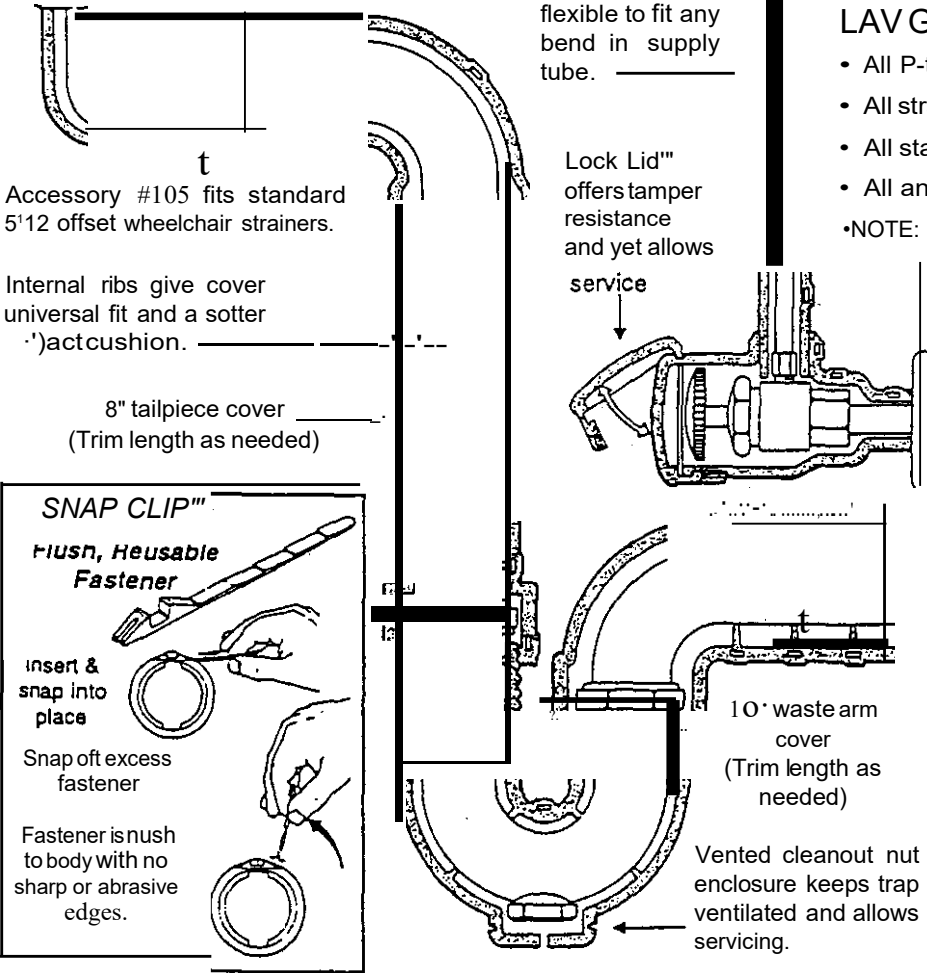

Accessory #105 fits standard 5/12 offset wheelchair strainers.

Internal ribs give cover universal fit and a softer cushion.

8" tailpiece cover (Trim length as needed)

#### SNAP CLIP™

Flush, Reusable Fastener

insert & snap into place

Snap off excess fastener

Fastener is flush to body with no sharp or abrasive edges.

10" waste arm cover (Trim length as needed)

Vented cleanout nut enclosure keeps trap ventilated and allows servicing.

MATERIAL:	MOLDED CLOSED CELL VINYL
NOM. WALL:	1/8 INCH CONSTANT
DUROMETER:	55 • 65 • SHORE A
UV PROTECTION:	WILL NOT FADE OR DISCOLOR
DURABILITY:	VIRTUALLY INDESTRUCTIBLE
FASTENERS:	SNAP-CLIP™. FLUSH, REUSABLE
COLOR:	LIGHT GREY OR WHITE
FINISHABILITY:	APPLY ACRYLIC ENAMEL
FLAMING CHARACTERISTICS	SELF-EXTINGUISHED
ASTM D 635:	5 second 10mm MELI
THERMAL CONDUCTIVITY	BTU • IN/HR • FT • OF
ASTM C 177:	K VALUE • 1.17
BACTERIA/FUNGUS RESIST:	ANTIMICROBIAL VINYL FORMULA
MAINTENANCE:	USE COMMON DETERGENTS

T&S BRASS AND BRONZE WORKS, INC.  
 2 SADDLEBACK COVE / P.O. BOX 1088 / TRAVELERS REST, SC 29690  
 PHONE 800-476-4103 FAX 864-834-3518

RECjA2ISO 1  
 ISO #9002

Model No.  
 B-0665-BSTP / R  
 Item No.:

Job Name:

Architect/Engineer Approval: 

Notes:

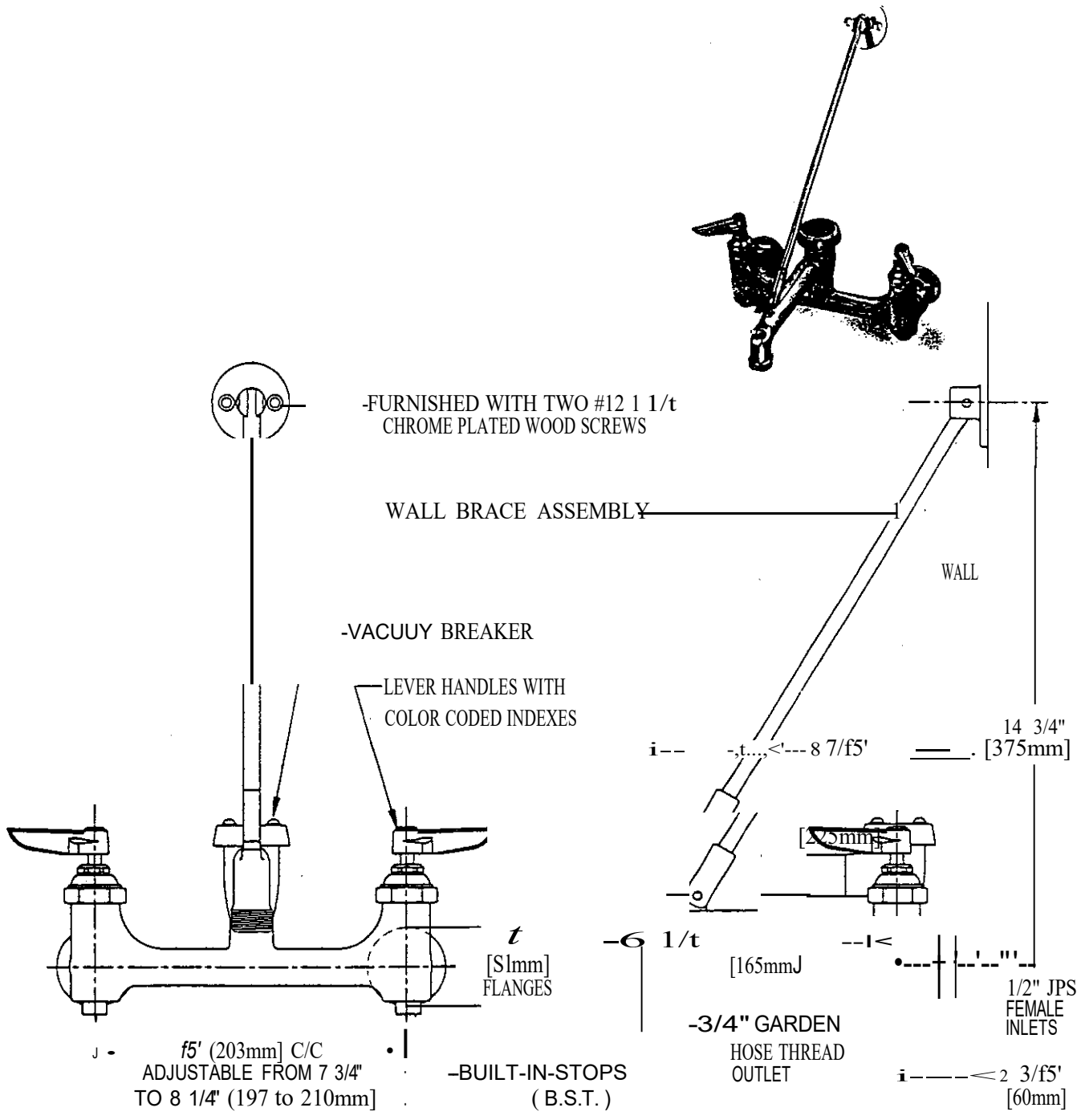

Product description:  
 SERVICE SINK FAUCET W/ BUILT IN STOPS, VACUUM BREAKER, LEVER HANDLES, WALL BRACE, AND AVAILABLE WITH ROUGH OR POLISHED CHROME FINISH

Drawn:  
 WJS  
 Approved  
 CA

Checked MW	Scale: 3" = 1'
Date:	

11/22/95

...+... C, \_...\_...{... (...  
rifi... ..  
-fi,4 #;

L "...,\_" Jrr. P...JJ.. c...1-

9-1 TUE 12:08 PM

WSC HARRISSBURG

FAX 717233191Q

•JP,,. r.HL...at

D. ., II

cc c..s ..er cu uc :csa...c" ..

- laundry faucets
- Z Hula installaUon
- 4•Centarset
- fJo/l" Long, 6 1/1." high spout swir9s 360"
- Blada handles
- Standard with '11" I.P.S.shanks
- 1/1" rap seal primer plug •

FINISH  
No.:

ouAmiri

j f

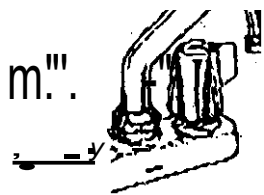

• WITH KDS( THREAD  
Chrome  
211-

W

• VANOAI RIISANT "CUUM  
8RUIEJIFOii US( WITH  
MDDfit131 "

Chrome  
RP?.5695  
-23.95

(6)ADA

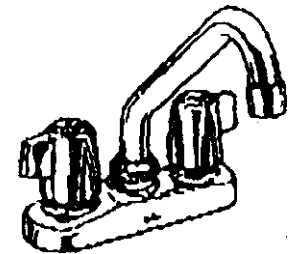

• INCLUDES STRUM ITIWCMT&MEI  
WITIOIT HOSETHRUO

Ctir < me

s lf9°

" Plug can be .-ernoved to attach a he which will enable floor drain trap to be refllod everytime faucet is used.



p<

# DELTA•L SPECIALTY FAUCETS

- Two Handle Laundry Faucet
- Deck Mount
- 2 Hole Sink Applications
- 4" (102 mm) Centerset

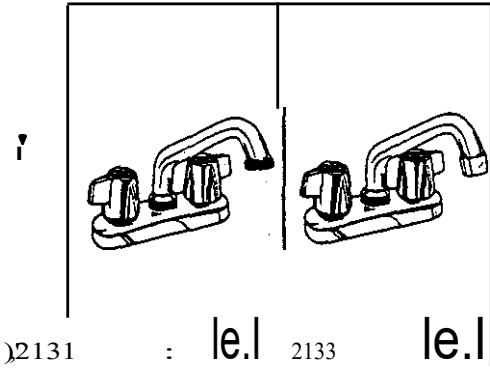

2131

le.l

2133

le.l

Submitted Model No.: \_\_\_\_\_

Specific Features: \_\_\_\_\_

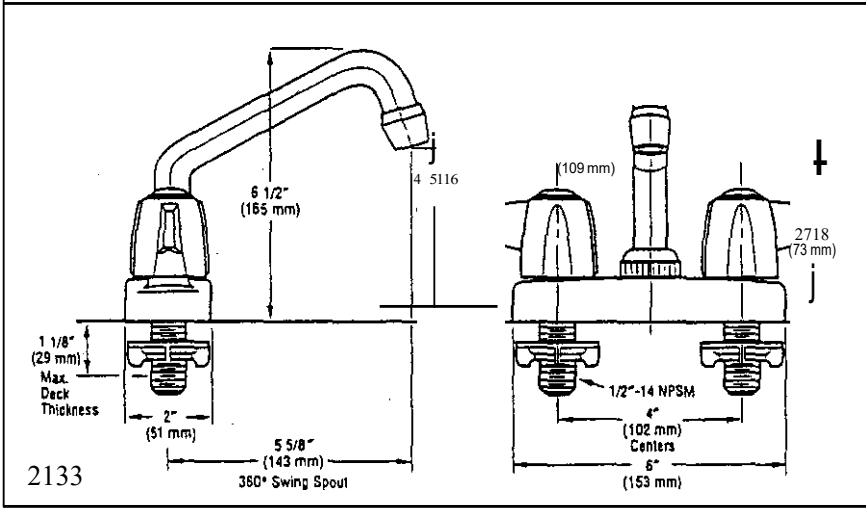
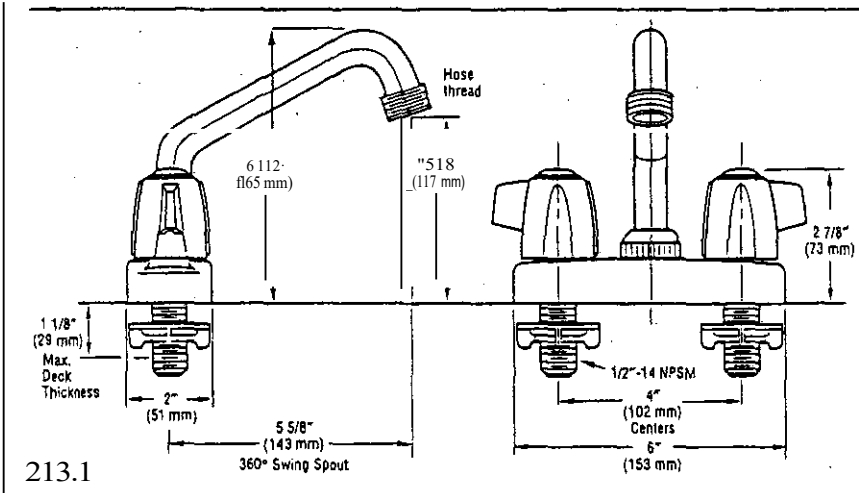

### COMPLIES WITH:

- ASME A112.18.1M-1996
- CSA 8125-93
- m Indicates ADA compHance to U2J CABO/ANSI A117.1-1992
- CSA Certified

### STANDARD SPECIFICATIONS:

- Two handle deck faucets for exposed mounting on 2 hole sinks.
- Solid brass fabricated body.
- 4" (102mm) Centeriet
- 5 5/8" (143 mm) long, 6 1/2" (165 mm) highspout swings 360°.
- Hot and cold stems are interchangeable.
- Control mechanism shall be of the rotating cylinder type with stainless steel plate and 180° rotation with replaceable non-metallic seats operating in stainless steel lined sockets.
- 1/2"-14 NPSM threaded male shanks
- Trap seal primer plug.

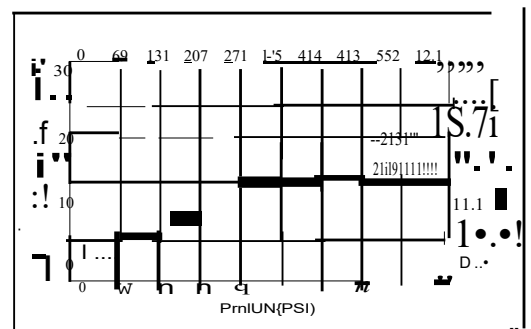

# MOP SERVICE BASIN 63M

## Specifications

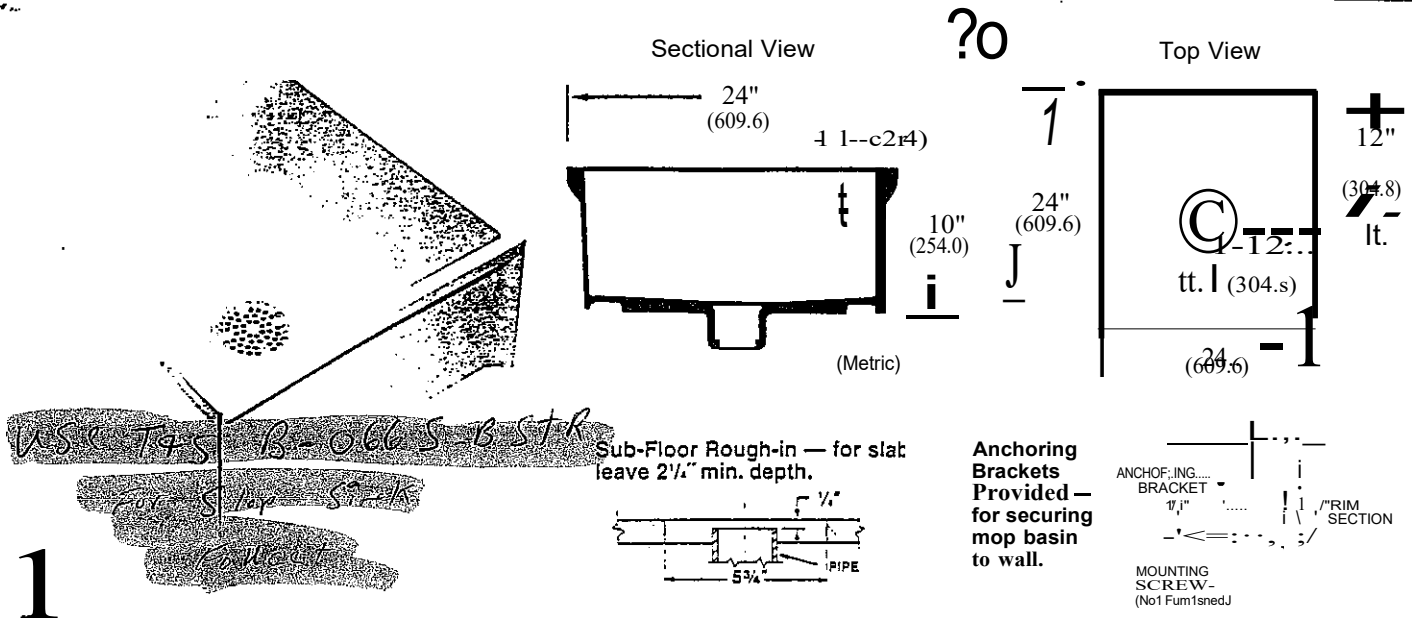

Model 63M Color White I.P.S.

Note: Replace furnished drain seal for installations with following pipe, order separately. Part #65.308 -for 2" PVC, ABS and iron pipe  
Part #65.311 -for 3" soil pipe (no hub)

General: Furnish and install as shown on plans, Mop Service Basin model 63M, as manufactured by E.L. Mustee & Sons, Inc. Unit to be one-piece molded fiberglass made with matched metal molds using extreme heat and pressure. Height shall be 10" with not less than 1" wide shoulder. Size 24"x24", Drain shall be integrally molded, complete with drain seal for installation of 3" ABS, PVC (Sch. #80) and iron pipe. Removable stainless steel strainer. Performance tested to meet or exceed ANSI Specifications Z 124.2, Z 124.6 and FHA/HUD UM-73. Weight 45 lbs., cubic feet 4.2. Install in compliance with local codes.

IAPMO<sup>o</sup> Listed  
File Numbers: Mop Basin -#2707

Warnock Hersey Listed  
CSA Test Standards: Mop Basin -#B45.0 & #B45.5

### ACCESSORIES -for complete details and specifications, specify literature ADV-357

Part No.	Description
63.600A	<b>O</b> SERVICE SINK FAUCET — brass, chrome plated, 8" centers
65.700	E') HOSE and HOSE HOLDER -31" hose and hose holder
65.600	<b>O</b> MOP HANGER -three handle holders
63.401	<b>O</b> BUMPER GUARDS — vinyl, protect rims, 20 1/2" length
67.2424	<b>O</b> DURAGUARD™ WALL GUARDS -two panels and corner bracket
67.24C	<b>O</b> DURAGUARD™ WALL GUARD — one panel and corner bracket
65.308	DRAIN SEAL — for 2" ABS, PVC and iron pipe
65.311	DRAIN SEAL — for 3" soil pipe (no hub)

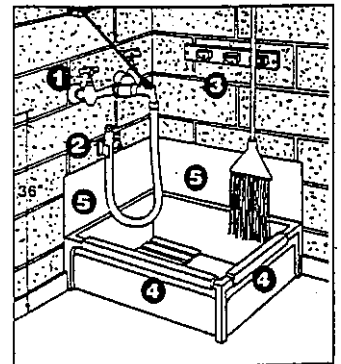

**A R I** ...  
include service sink faucet, hose and hose holder. Ideal for bathing pets, cleaning garden utensils, toys, tools, etc.

# MUSTEE

## Thermoplastic and Durastone® Laundry/Utility Trays

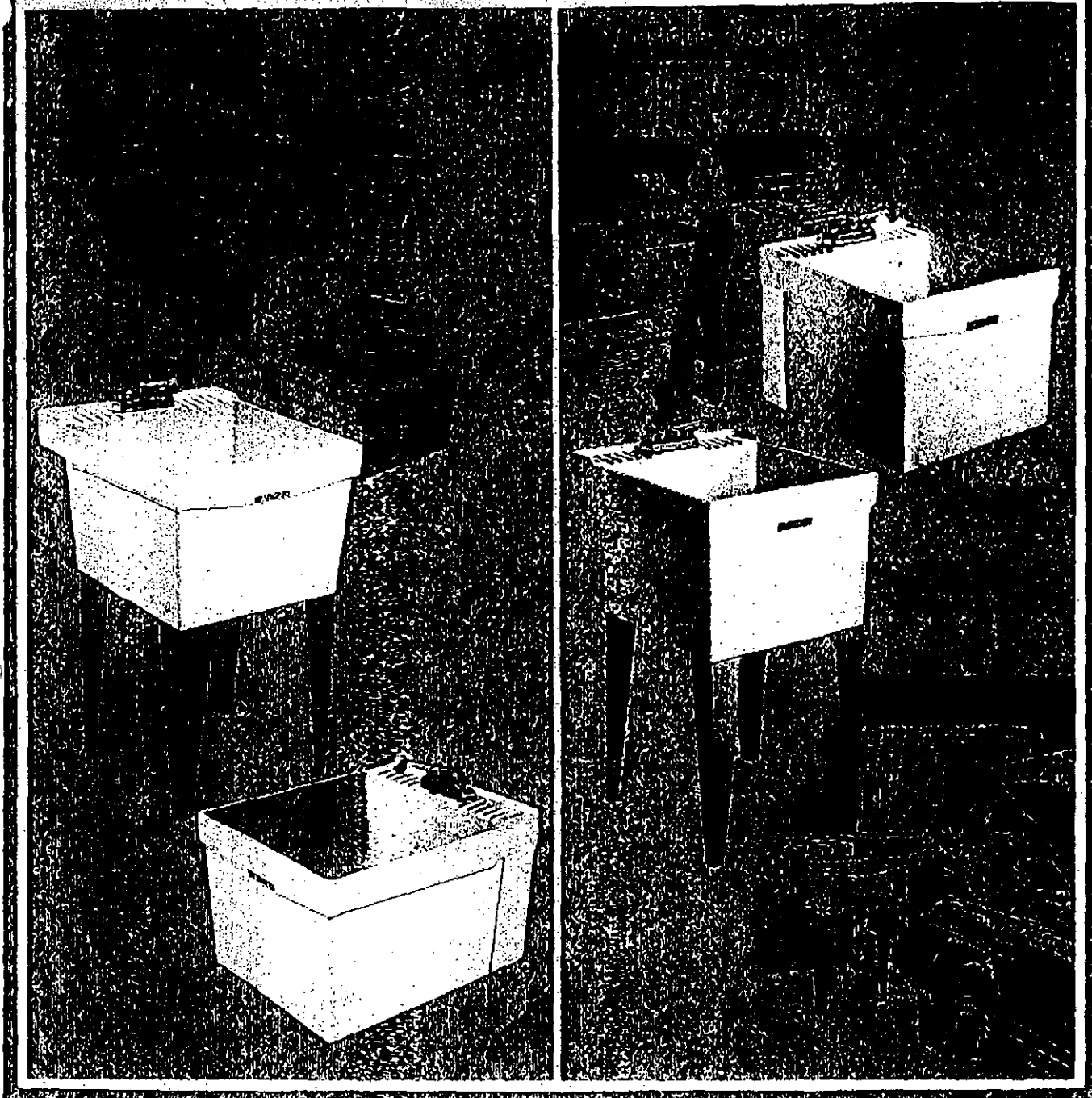

### UTILATUB® 19/18

Model #  
MUI9F

Mustee's UTILATUBS™ are designed with many built-in features. Sturdy floor and wall mounted models are extra tough, stain-resistant, attractive... and provide years of dependable performance.

When it's time to tackle those "tough" cleanup jobs... messy painting utensils and garden tools, family pets, grimy dirt from working on your car, doing the laundry, etc., etc., nothing works better than the convenience of a UTILATUB. So don't wait, install one next to your workbench, in your basement, garage, utility room, breezeway, on your patio... or anywhere.

# UTILATUB 19

## Thermoplastic Laundry/Utility Tubs

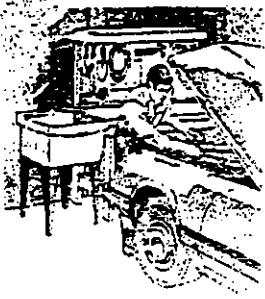

PREFERRED BY  
7K "P/z-04,"

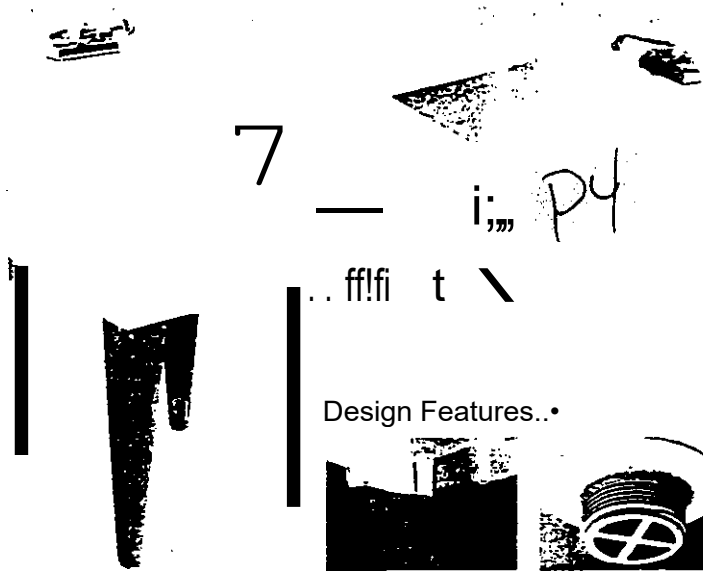

Design Features..

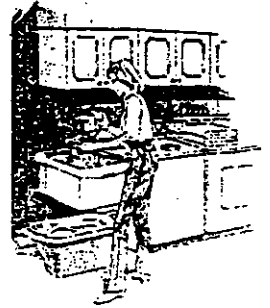

CODE APPROVED  
/M

- STURDY, 1-PIECE MOLDED TUBS, MADE WITH STRUCTURAL THERMOPLASTIC
- LEAKPROOF 1" INTEGRAL DRAIN
- FLOOR and WALL MOUNTED MODELS,

- 18 GALLON CAPACITY, 13" DEEP, ONLY 20" WIDE
- SMOOTH WHITE SURFACE, RUST-RESISTANT

W. ....

International Association of Plumbing and Mechanical Officials (IAPMO®)-listed file #0820

LEVELERS and STOPPER INCLUDED

8 EASY TO INSTALL

CODE

American National Standards Institute (ANSI)-Specification Z 124.6

APPROVED

Warnock Hersey® (Canada)-CSA #645.0 and 645.5

### SPECIFICATIONS

Top View

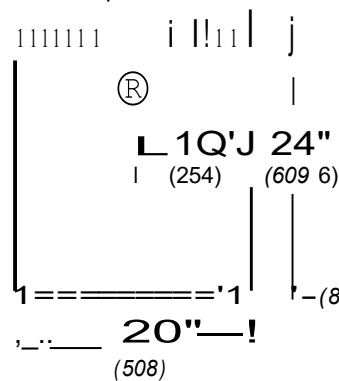

(Metric)

Side Views

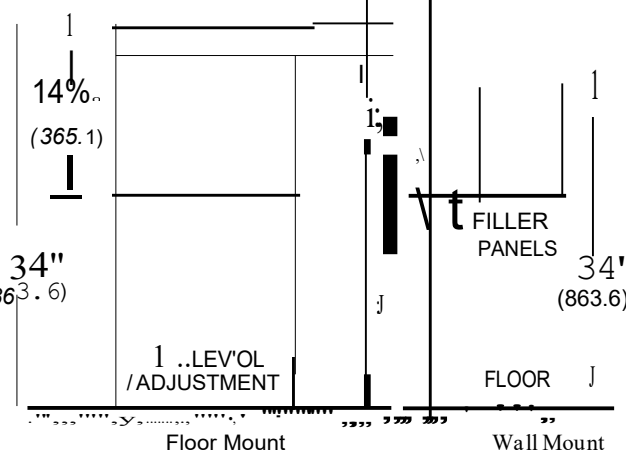

Model No.

Mounting

General: Furnish and install as shown on plans, UTILATUB® Laundry/Utility Tub model (19F, 19W), as manufactured by E.L. Mustee & Sons, Inc. Tub shall be one-piece molded construction using structural thermoplastic with matched metal molds under extreme heat and pressure. Tub to include integrally molded drain assembly stopper and floor or wall mounting hardware. Shall meet ANSI Specification Z 124.6. White color. 19F weight 23 lbs.. 19W 20 lbs., cubic ft. 4.8.

### ACCESSORIES.....

FAUCET #93.600-chrome-plated brass body. 4-center set, swing spout with

FAUCET #91.604-chrome-plated brass body and 1.1-bular swing spout

FAUCET #90.700-clamp-on for overhead water supply. brass body with swing-spout and hose end

MOLDED FAUCET BLOC! (#20.600-used with clamp-on faucet

OVERFLOW PREVENTER #27.600C-prevents water

HANOFLOW! FITTING #94.700" discharges water from

end.4" center set

overflow

washer  
into tub

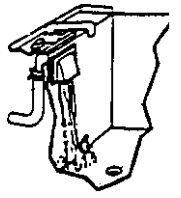

@ Mbj, § S

5431 W. 164th St, Cleveland,

44142 • Phone (216) 267-3100, Fax (216) 267-9997



URINAL FLUSHOMETER

# Regal® Model 186 Flushometer

186-1 *MAC Standard*  
186-0.5

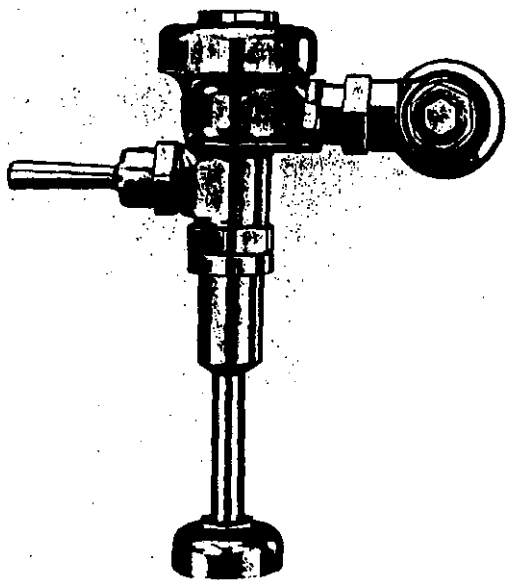

**Description**

Exposed Urinal Flushometer for 1/2" tap spud urinals.

**Flush Cycle**

- Model 186 Water Saver (1.5 gpf/5.7 LpQ)
- Model 186-1 Low Consumption (1.0 gpf/3.8 LPO)
- Model 186-0.5 (0.5 gpf/1.9 LpQ)

**Specifications**

Quiet, Exposed, Diaphragm Type, Chrome Plate Urinal Flushometer with the following features:

- Metal Oscillating Non-Hold-Open Handle
- LP\$. Screwdriver Bak-Chek™ Angle Stop
- Vandal Resistant Stop Cap
- Adjustable Tailpiece
- Vacuum Breaker Flush Connection
- Spud Coupling, Wall and Spud Flange for 3/4" Top Spud
- Low Consumption flush accuracy controlled by Para-Flo™ Inside Parts Kit
- Handle Packing, Stop Seat and Vacuum Breaker to be molded from PEAMEX™ rubber compound for Chloramine resistance

Valve Body, Cover, Tailpiece and Control Stop shall be in conformance with ASTM Alloy Classification for Semi-Red Brass. Valve shall be in compliance to the applicable sections of ASSE 1037, ANSISME 112.19.6, and Military Specification V-29193.

**Variations**

- ADA ADA Compliant Handle **II**
- BG Bio-Gard™ Handle **III**
- YB Sweat Solder Adapter Kit with Stamped Flange
- YBYC Sweat Solder Adapter & Cast Wall Flange w/Set Screw

**REGALXI**

Flushometer includes ADA Compliant Handle, Vandal Resistant Stop Cap with Set Screw, and Sweat Solder Adapter with Cover Tube and Cast Set Screw Wall Flange.

See Accessories Section of the Sloan catalog for details on these and other Flushometer variations.

@® Certified

® Listed by IAP.M.O.

This space for Architect/Engineer approval

The information contained in this document is subject to change without notice.

# SLOAN.

Made in the U.S.A.

SLOAN VALVE COMPANY • 10500 SEYMOUR AVE. • FRANKLIN PARK, IL 60131  
PHONE: 1-800-982-5639 • FAX: 1-800-447-8329 • <http://www.sloanvalve.com>

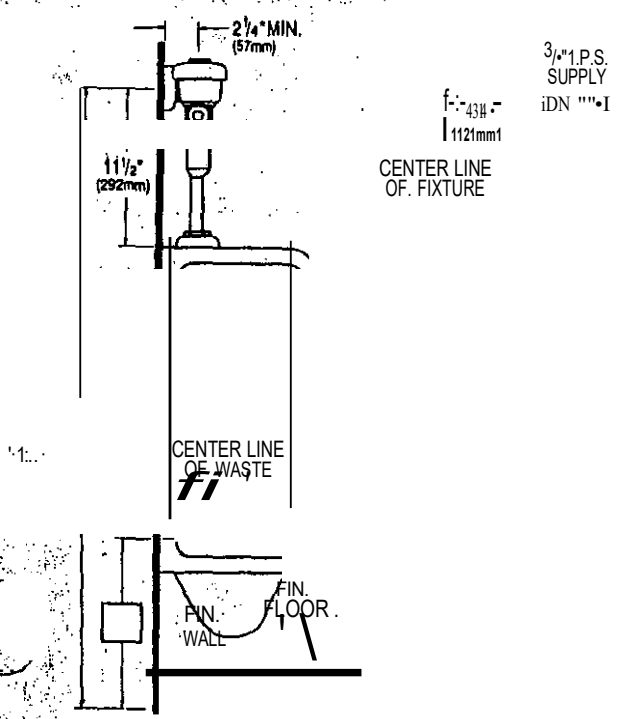

# 195 ES-S 195-1 ES-S 195-0.5 ES-S

..... Description  
Concealed Sensor Operated Urinal Flushometer, for 3/4" back spud urinals.

- ||o- Flush Cycle
- D Model 195 ES-S Water Saver (1.5 gpf/5.7 Lpn)
  - g Model 195-1 ES-S Low Consumption (1.0 gpf/3.8 Lpn)
  - O Model 195-0.5 ES-S (0.5 gpf/1.9 Lpn)

- ..... Specifications
- Quiet, Concealed, Diaphragm Type, Rough Brass Urinal Flushometer for either left or right hand supply with the following features:
- Dual Filtered By-Pass
  - OPTIMA7.I EL-1500 Self Adaptive Infrared Sensor with Indicator Light
  - Non-Hold-Open Integral Solenoid Operator
  - Chrome Plated Wall Cover Plate (for 2-gang Electrical Box) with Vandal Resistant Screws
  - 3/4" I.P.S. Wheel Handle Bak-Chek™ Angle Stop
  - Sweat Solder Adapter
  - Adjustable Tailpiece
  - High Back Pressure Vacuum Breaker Flush Connection and Spud Coupling for 3/4" Concealed Back Spud

Valve Body, Cover, Tailpiece and Control Stop shall be in conformance with ASTM Alloy Classification for Semi-Red Brass. Valve shall be in compliance with the applicable sections of ASSE 1037, ANSI/ASME A112.19.6 and Military Specification V-29193. Installation conforms to ADA requirements.

..... L Dimension  
Specify the "L" Dimension for the proper length of the Flush Connection. The "L" Dimension is equal to the Wall Thickness (to the nearest whole inch) plus 23/16".

- ..... Accessories
- O EL-154 Transformer (120 VAC/24 VAC 50 VA.)
  - O EL-342 Transformer (240 VAC/24 VAC 50 VA.)

See Accessories Section and Optima Accessories Section of the Sloan catalog for details on these and other Optima Flushometer variations.

® Listed    ® Listed     listed by AP.M.O.

This space for Architect/Engineer approval

Job Name \_\_\_\_\_ Date \_\_\_\_\_

Model Specified \_\_\_\_\_ Quantity \_\_\_\_\_

Variations Specified \_\_\_\_\_

Customer/Wholesaler \_\_\_\_\_

Contractor \_\_\_\_\_

Architect \_\_\_\_\_

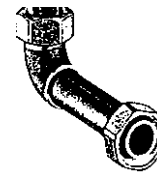
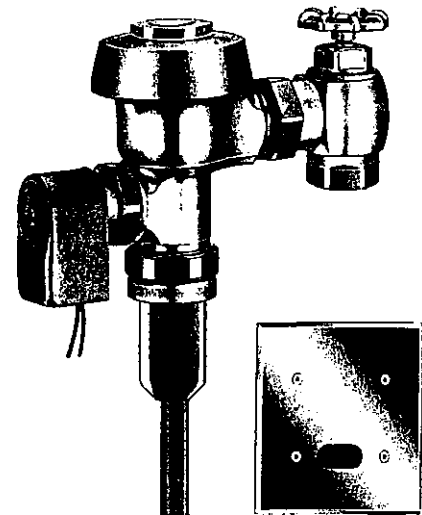

..... Automatic  
Sloan OPTIMA; equipped Flushometers provide the ultimate in sanitary protection and automatic operation. There are no handles to trip or buttons to push. The Flushometer operates by means of an infrared sensor that adapts to its surroundings. Once the user enters the sensor's effective range and then steps away, the Flushometer Solenoid initiates the flushing cycle to flush the fixture.

||o- Hygienic  
User makes no physical contact with the Flushometer surface. Helps to control the spread of infectious diseases. 24 Hour Sentinel Flush keeps fixture fresh during periods of non-use.

..... Economical  
Automatic operation provides savings in water over other flushing devices. Reduces maintenance and operation costs.

Practical  
Solid state electronic circuitry assures years of dependable, trouble-free operation. The operational components of the Flushometer are identical to a handle operated Royal Flushometer, proven by 90 years of experience.

||o- Warranty  
3 year (limited)

||o- Made in the U.S.A.



# 195 ES-S 195-1 ES-S 195-0.5 ES-S

## .... Description

Concealed Sensor Operated Urinal Flushometer, for 34" back spud urinals.

## Flush Cycle

D Model 195 ES-S Water Saver (t.5 gpf/5.7 Lp0)

D Model 195-1 ES-S Low Consumption (1.0 gpf/3.8 Lp0)

0 Model 195-0.5 ES-S (0.5 gpf/1.9 Lp0)

## ELECTRICAL SPECIFICATIONS

### .... Control Circuit

Solid State  
24 VAC Input  
24 VAC Output  
B sec. Arming Delay  
24 Hour Sentinel Flush

### OPTIMA Sensor Range

Nominal 15'-30" (381-762mm)  
Self-adaptive Window: ± 8" (203mm)

### .... Solenoid Operator

24 VAC, 50/60 Hz

### Transformers

Sloan Part #EL-154  
120 VAC, 50/60 Hz Primary  
24 VAC, 50/60 Hz Secondary  
Class II, UL Listed  
50 VA.

### Sloan Part #EL-342

240 VAC, 50/60 Hz Primary  
24 VAC, 50/60 Hz Secondary  
Class II, UL Listed  
50 VA.

One Transformer serves up to ten (10) OPTIMA Closet/Urinal Flushometers. Specify number of transformers required accordingly.

## WIRING DIAGRAM

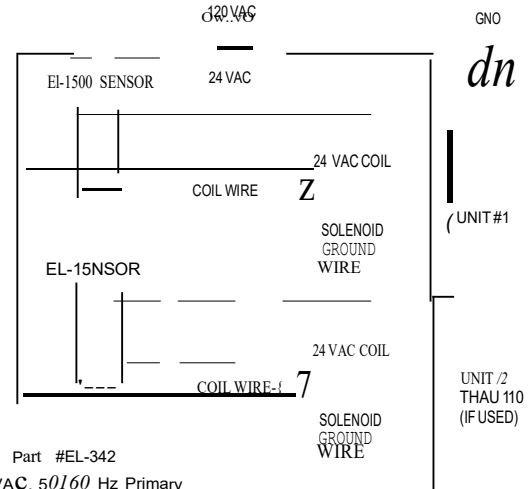

## OPERATION

1.

A continuous, invisible light beam is emitted from the OPTIMA Sensor.

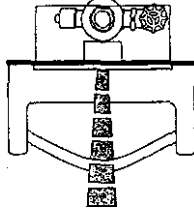

2.

As the user enters the beam's effective range (15" to 30") the beam is reflected into the OPTIMA's Scanner Window and transformed into a low voltage electrical circuit. Once activated, the Output Circuit continues in a "hold" mode for as long as the user remains within the effective range of the Sensor.

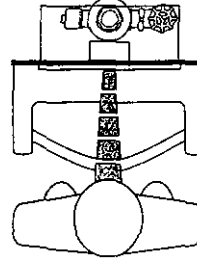

3.

When the user steps away from the OPTIMA Sensor, the circuit immediately initiates an electrical "one-time" signal that operates the Solenoid. This initiates the flushing cycle to flush the fixture. The Circuit then automatically resets and is ready for the next user.

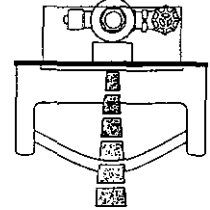

L Dim.  
23/4" (70 mm) ± I  
+ WALL  
THICKNESS

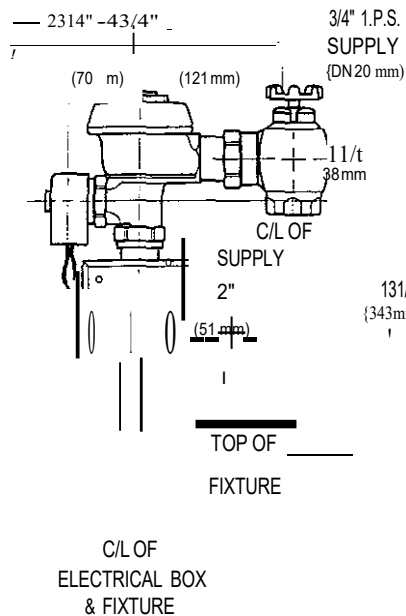

## ELECTRICAL BOX INSTALLATION

### SENSOR LOCATION AND POSITIONING IS CRITICAL

Failure to properly position the electrical boxes to the plumbing rough-in will result in improper installation and impair product performance. All tradesmen (plumbers, electricians, tile setters, etc.) involved with the installation of this product must coordinate their work to assure proper product installation.

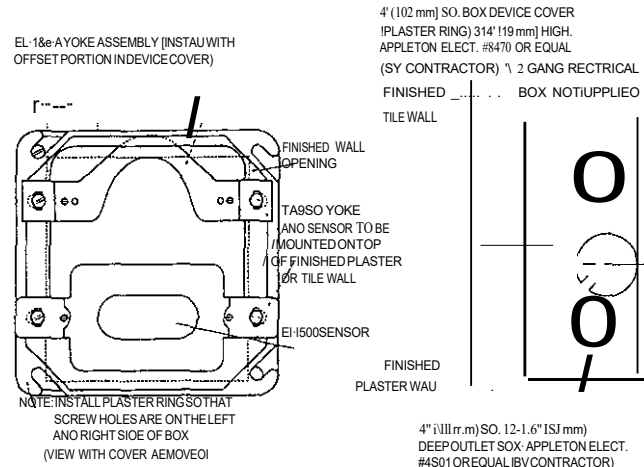

SLOAN VALVE COMPANY • 10500 SEYMOUR AVENUE • FRANKLIN PARK, ILLINOIS 60131

toilet flusher

# Regal® Model 110 Flushometer

110  
111 Mc Standard

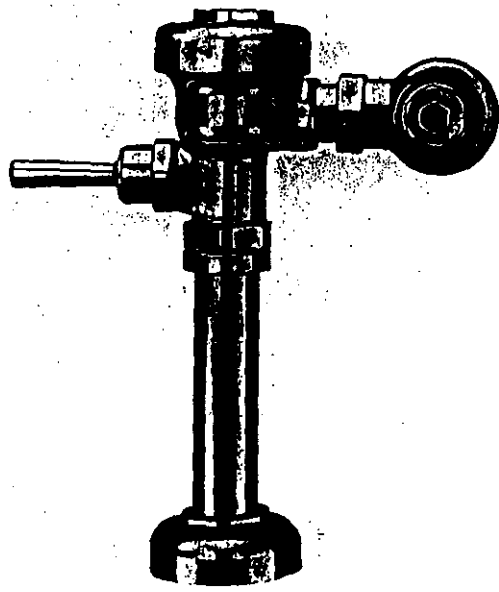

III > Description  
Exposed Water Closet Flushometer, (of floor mounted or wall hung top spud b/wls.)

III > Flush Cycle:  
 O Model 110 Water Saver (3.5 gpt/13.2 Lp)j  
 O Model 111 Low Consumption (1.6 gpf/6.0 LpO

..... Specifications

Quiet, Exposed, Diaphragm Type, Chrome Plated Closet Flushometer with the following features:

- Metal Oscmating Non-Hold-Open Handle
- 1" I.P.S. Screwdriver Bak-Chek™ Angle Stop
- Vandal Resistant Stop Cap
- Adjustable Tailpiece
- Vacuum Breaker.. Flush Connection
- Spud Coupling, Wall and Spud Flanges for 1 1/2" Top Spud
- Low Consumption flush accuracy controlled by Para-Flo™ Inside Parts Kit
- Handle Packing, Stop Seat and Vacuum Breaker lobe molded from PERMEX™ rubber compound for Chloramine resistance

Valve Body, Cover, Tailpiece and Control Stop shall be in conformance with ASTM Alloy Classification for Semi-Red Brass. Valve shall be in compliance to the applicable sections of ASSE 1037, ANSI/ASME 112.19.6, and Military Specification V-29193.

... variations

- O ADA ADA Compliant Handle II
- O BG Bio-Gard™ Handle II
- O DTP Trap Primer
- O YB Sweat Solder Adapter Kit with Stamped Flange
- O YBYC Sweat Solder Adapter & Cast Wall Flange w/Set Screw
- O YO Bumper on Angle Stop

O REGAL XL  
 Flushometer Includes ADA Compliant Handle, Vandal Resistant Stop Cap with Set Screw, and Sweat Solder Adapter with Cover Tube and Cast Set Screw Wall Flange.

• see Accessories Section of the Sloan catalog for details on these and other Flushometer variations.

© Certified

© listed by t.A.P.M.O.

This space for Architect/Engineer approval

The information contained in this document is submitted to change without notice. Made in the U.S.A.

# SLOAN.

SLOAN VALVE COMPANY • 10500 SEYMOUR W.E. • FRANKLIN PARK, L 60131  
 PHONE: 1-800-982-5639 • FAX: 1-800-447-8329 • <http://www.sloanvalve.com>

/-  
\\.

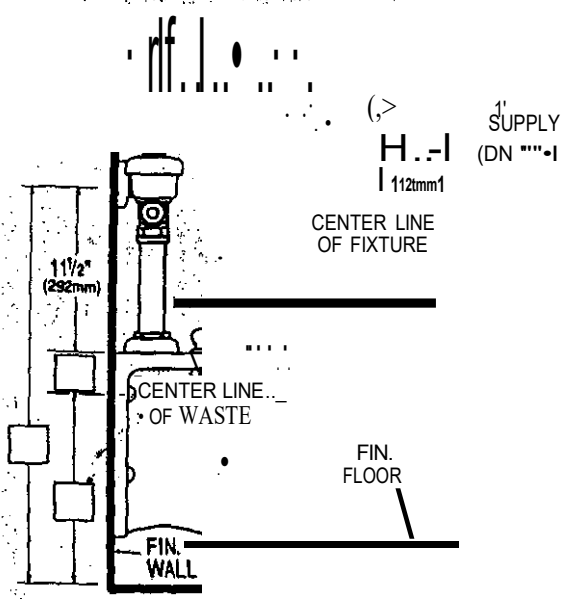

# 152 ES-S 152-1.6 ES-S

► **Description**  
Concealed Sensor Operated Water Closet Flushometer, for wall hung back spud bowls.

**Flush Cycle**

- Model 152 ES-S Water Saver (3.5 gpf/13.2 LpD)
- Model 152-1.6 ES-S Low Consumption (1.6 gpf/6.0 LpD)

**Specifications**

Quiet, Concealed, Diaphragm Type, Rough Brass Closet Flushometer with the following features:

- Dual Filtered By-Pass
- OPTIMA™ EL-150 Self Adaptive Infrared Sensor with Indicator Light
- Courtesy Flush™ Over-ride Button
- Non-Hold-Open Integral Solenoid Operator
- Chrome Plated Wall Cover Plate (for 2-gang Electrical Box) with Vandal Resistant Screws
- 1" LP.S. Wheel Handle Bak-Chek™ Angle Stop
- Sweat Solder Adapter
- Adjustable Tailpiece
- High Back Pressure Vacuum Breaker Flush Connection and Spud Coupling for 1Y2" Concealed Back Spud

Valve Body, Cover, Tailpiece and Control Stop shall be in conformance with ASTM Alloy Classification for Semi-Red Brass. Valve shall be in compliance with the applicable sections of ASSE 1037, ANSI/ASME A 112.19.6 and Military Specification V-29193. Installation conforms to ADA requirements.

..... **L Dimension**  
Specify the "L" Dimension for the proper length of the Flush Connection. The "L" Dimension is equal to the Wall Thickness (to the nearest whole inch) plus 23/4".

..... **Variations**  
**DTP** Trap Primer Elbow  
**DYI** Two Wan Bumpers (tor open front seat without cover)

.... **Accessories**  
 EL-154 Transformer (120 VAC/24 VAC 50 VA.)  
 EL-342 Transformer (240 VAC/24 VAC 50 VA.)

See Accessories Section and Optima Accessories Section of the Sloan catalog for details on these and other Optima Flushometer variations.

® Listed    @® Listed    ® Listed by I.A.P.M.O.

This space for Architect/Engineer approval

Job Name \_\_\_\_\_ Date \_\_\_\_\_

Model Specified \_\_\_\_\_ Quantity \_\_\_\_\_

Variations \_\_\_\_\_ Specified \_\_\_\_\_

Customer/Wholesaler \_\_\_\_\_

Contractor \_\_\_\_\_

Architect \_\_\_\_\_

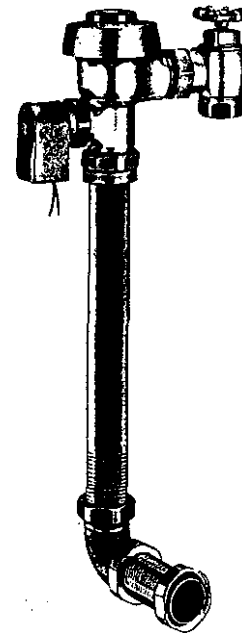

.... **Automatic**  
Sloan OPTIMA™ Flushometers provide the ultimate in sanitary protection and automatic operation. There are no handles to trip or buttons to push. The Flushometer operates by means of an infrared sensor that adapts to its surroundings. Once the user enters the sensor's effective range and then steps away, the Flushometer Solenoid initiates the flushing cycle to flush the fixture.

**Hygienic**  
User makes no physical contact with the Flushometer surface. Helps to control the spread of infectious diseases. 24 Hour Sentinel Flush keeps fixture fresh during periods of non-use.

**Economical**  
Automatic operation provides savings in water over other flushing devices. Reduces maintenance and operation costs.

**Practical**  
Solid state electronic circuitry assures years of dependable, trouble-free operation. The operational components of the Flushometer are identical to a handle operated Royal Flushometer, proven by 90 years of experience.

.... **Warranty**  
3 year (limited)

.... **Made in the U.S.A.**

# 152 ES-S 152-1.6 ES-S

## Description

Concealed Sensor Operated Water Closet Flushometer, for wall hung back spud bowls.

## Flush Cycle

**CJ** Model 152 ES-S Water Saver (3.5 gpf/13.2 Lpf)

**iJ** Model 152-1.6 ES-S Low Consumption (1.6 gpf/6.0 Lpf)

## ELECTRICAL SPECIFICATIONS

### Control Circuit

Solid State  
24 VAC Input  
24 VAC Output  
8 sec. Arming Delay  
3 sec. Flush Delay  
24 Hour Sentinel Flush

### OPTIMA Sensor Range

Nominal 22"-42" (559-1067mm)  
Self-adaptive Window: ± 10" (254mm)

### Solenoid Operator

24 VAC, 50/60 Hz

### Transformers

Sloan Part #EL-154  
120VAC, 50/60 Hz Primary  
24 VAC, 50/60 Hz Secondary  
Class II, UL Listed  
50 VA.

### Sloan Part #EL-342

240 VAC, 50/60 Hz Primary  
24 VAC, 50/60 Hz Secondary  
Class II, UL Listed  
50 VA.

## WIRING DIAGRAM

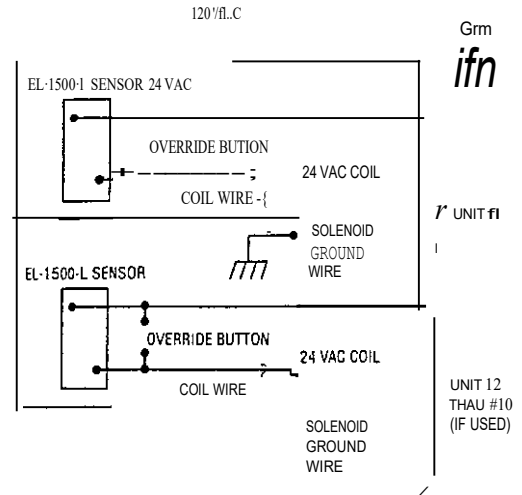

One Transformer serves up to ten (10) OPTIMA Closet/Urinal Flushometers. Specify number of transformers required accordingly.

## OPERATION

1. A continuous, invisible light beam is emitted from the OPTIMA Sensor.

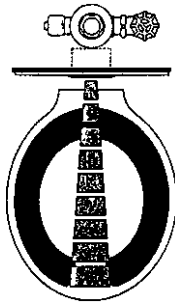

2. As the user enters the beam's effective range (22" to 42") the beam is reflected into the OPTIMA's Scanner Window and transformed into a low voltage electrical circuit. Once activated, the Output Circuit continues in a "hold" mode for as long as the user remains within the effective range of the Sensor.

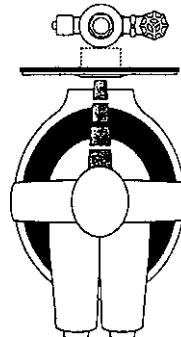

3. When the user steps away from the OPTIMA Sensor, the circuit waits 3 seconds (to prevent false flushing) then initiates an electrical "one-time" signal that operates the Solenoid. This initiates the flushing cycle to flush the fixture. The Circuit then automatically resets and is ready for the next user.

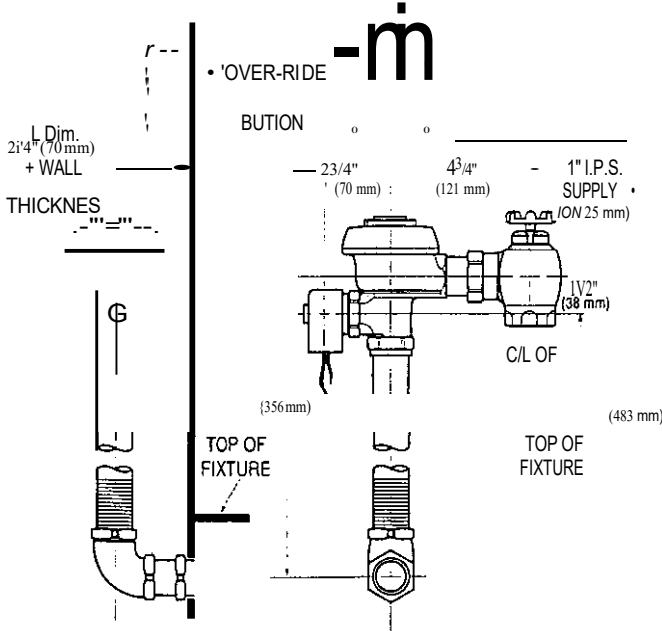
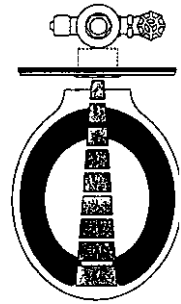

Position of Sensor Box can be raised or lowered 1" (25 mm) if in conflict with Handicap Grab Bars.

## ELECTRICAL BOX INSTALLATION LOCATION AND POSITIONING IS CRITICAL

Failure to properly position the electrical boxes to the plumbing rough-in will result in improper installation and impair product performance. All tradesmen (plumbers, electricians, tile setters, etc.) involved with the installation of this product must coordinate their work to assure proper product installation.

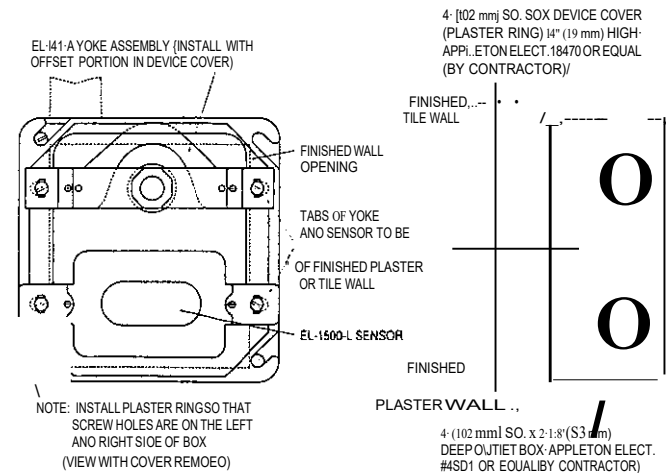

## 8110-MC 8111-MC

**Description**

Exposed, Battery Powered, Sensor Operated Royal Water Closet Flushometer with Metal Cover, for floor mounted or wall hung top spud bowls.

**Flush Cycle**

0 Model 8110-MC Water Saver (3.5 gpf/13.2 LpD

Model 8111-MC Low Consumption (1.6 gpf/6.0 LpD

**Specifications**

Quiet, Exposed, Diaphragm Type, Chrome Plated Closet Flushometer for either left or right hand supply with the following features:

- ADA Compliant OptimaPLUS™ Battery Powered Infrared Sensor for automatic "No Hands" operation
- Dual Filtered By-Pass
- Diaphragm, Stop Seat and Vacuum Breaker to be molded from PERMEX™ rubber compound for Chloramine resistance

**Chrome Plated, Die Cast Metal Cover Assembly with Tempered Glass Window**

- User friendly 3 second Flush delay
- Courtesy Flush™ Over-ride Button
- Four (4) size AA Batteries included
- "Low Battery" Flashing LED
- Infrared Sensor Range Adjustment Screw
- Initial Set-Up Range Indicator Light (first 10 minutes)
- Solid Handle Cap
- 1" I.P.S. Screwdriver Bak-Chek™ Angle Stop
- Free Spinning Vandal Resistant Stop Cap
- Sweat Solder Adapter with Cover Tube and Cast Set Screw Wall Flange
- Adjustable Tailpiece
- High Back Pressure Vacuum Breaker Flush Connection with One-piece Bottom Hex Coupling Nut
- Spud Coupling and Flange for 1/2" Top Spud

Valve Body, Tailpiece and Control Stop shall be in conformance with ASTM Alloy Classification for Semi-Red Brass. Valve shall be in compliance with the applicable sections of ASSE 1037, ANS/ASME A 112.19.6 and Military Specification V-29193. Valve shall conform to A.O.A. requirements.

**Variations**

D LH Less Handle Opening

See Accessories Section and Optima Accessories Section of the Sloan catalog for details on these and other Optima Plus Flushometer variations

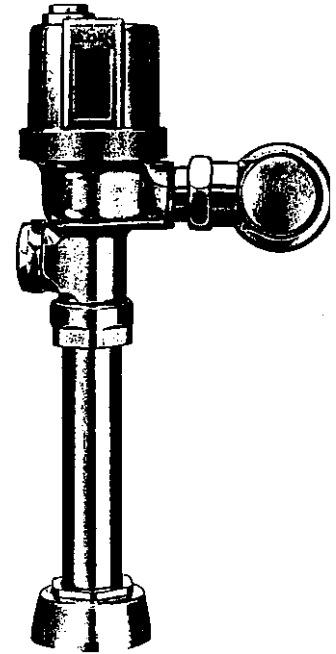

ADA Compliant

**Automatic**

Sloan OPTIMA Plus' equipped Flushometers provide the ultimate in sanitary protection and automatic operation. There is no need for AC hookups or wall alterations. The Flushometer operates by means of a battery powered infrared sensor. Once the user enters the sensor's effective range and then steps away, the Flushometer Solenoid initiates the flushing cycle to flush the fixture.

**Hygienic**

User makes no physical contact with the Flushometer surface except to initiate the Over-ride Button when required. Helps to control the spread of infectious diseases.

**Economical**

Automatic operation provides savings in water usage over other flushing devices. Reduces maintenance and operation costs.

**Warranty**

3 year (limited)

Made in the U.S.A.

® Listed

@ Listed

The information contained in this document is subject to change without notice.

This space for Architect/Engineer approval	
Job Name _____	Date _____
Model Specified _____	Quantity _____
Variations Specified _____	
Customer/wholesaler _____	
Contractor _____	
Architect _____	

# 8110-MC 8111-MC

## Description

Exposed, Battery Powered, Sensor Operated Royal Water Closet Flushometer with Metal Cover, for floor mounted or wall hung top spud bowls.

## Flush Cycle

0 Model 8110-MC Water Saver (3.5 gpf/13.2 Lpf)

0 Model 8111-MC Low Consumption (1.6 gpf/6.0 Lpf)

## ELECTRICAL SPECIFICATIONS

- Control Circuit
  - Solid State
  - 6 VDC Input
  - 8 sec. Arming Delay
  - 3 sec. Flush Delay
  - 24 Hour Sentinel Flush
- OPTIMA Sensor Type
  - Active Infrared
- OPTIMA Sensor Range
  - Nominal 22"-42" (559-1067mm),
  - adjustable  $\pm 8"$  (203mm)
- Battery Type
  - (4) AA Alkaline
- Battery Life
  - 3 years @ 4,000 flushes/month
- Indicator Lights
  - Range Adjustment/Low Battery
- Sentinel Flush
  - Once every 24 hours after the last flush

21 1/4" MIN.  
(57mm)

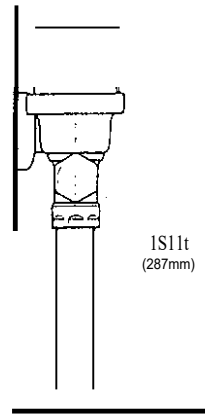

C/L OF  
FIXTURE

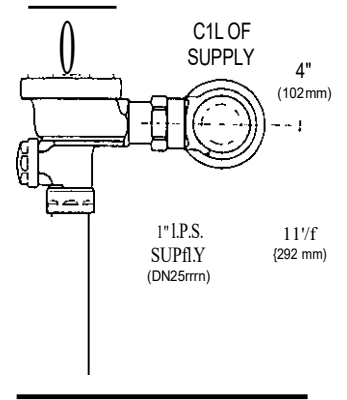

C/L OF  
FIXTURE

## OPERATION

1. A continuous, invisible light beam is emitted from the OPTIMA Plus Sensor.

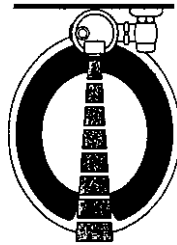

2. As the user enters the beam's effective range (22" to 42") the beam is reflected into the OPTIMA Plus' Scanner Window and transformed into a low voltage electrical circuit. Once activated, the Output Circuit continues in a "hold" mode for as long as the user remains within the effective range of the Sensor,

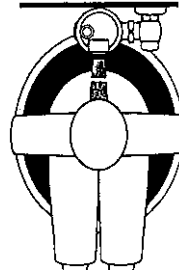

3. When the user steps away from the OPTIMA Plus Sensor, the circuit waits 3 seconds (to prevent false flushing) then initiates an electrical signal that operates the Solenoid. This initiates the flushing cycle to flush the fixture. The Circuit then auto-matically resets and is ready for the next user.

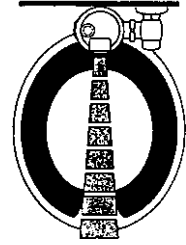

## VARIATIONS

OLH  
LESS HANDLE  
OPENING

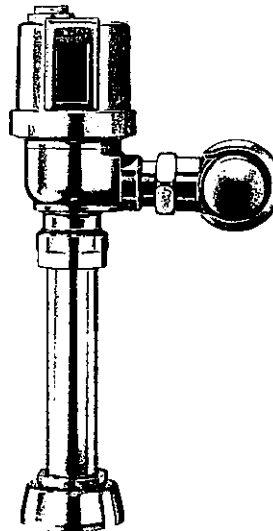

# SLOAN

OPTIMA SYSTEMS

Royal® **OP IM**  
Model *p'fu*

Battery Powered Flushometers

8186  
8186-1.0  
8186-0.5

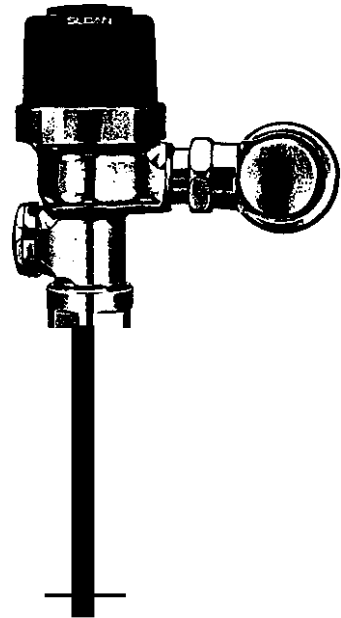

**Description**  
Exposed. Battery Powered, Sensor Operated Royal Urinal Flushometer.

**Flush Cycle**  
 Model 8186 Water Saver (1.5 gpf/5.7 LpD)  
 Model 8186-1.0 Low Consumption (1.0 gpf/3.8 LpD)  
 Model 8186-0.5 (0.5 gpf/1.9 LpD)

**Specifications**  
Quiet, Exposed, Diaphragm Type, Chrome Plated Urinal Flushometer for either left or right hand supply with the following features:

- ADA Compliant OptimaPLUS Battery Powered Infrared Sensor for automatic "No Hands" operation
- Dual Filtered By-Pass
- Diaphragm, Stop Seat and Vacuum Breaker to be molded from PERMEX™ rubber compound for Chloramine resistance
- Engineered Plastic Cover Assembly with Integral Window
- Four (4) size AA Batteries included
- "Low Battery" Flashing LED
- Infrared Sensor Range Adjustment Screw
- Initial Set-Up Range Indicator Light (first 10 minutes)
- Solid Handle Cap
- 3/4" LP.S. Screwdriver Bak-Chek™ Angle Stop
- Free Spinning Vandal Resistant Stop Cap
- Sweat Solder Adapter with Cover Tube and Cast Set Screw Wall Flange
- Adjustable Tailpiece
- High Back Pressure Vacuum Breaker Flush Connection with One-piece Bottom Hex Coupting Nut
- Spud Coupling and Flange for 3/4" Top Spud

Valve Body, Tailpiece and Control Stop shall be in conformance with ASTM Alloy Classification for Semi-Red Brass. Valve shall be in compliance with the applicable sections of ASSE 1037, ANSI/ASME A112.19.6 and Military Specification V-29193. Valve shall conform to A.O.A. requirements.

**Variations**  
 BO Beam Deflector (for targeting small children and wheelchair users)  
 LH Less Handle Opening  
 MC Metal Cover

See Accessories Section and Optima Accessories Section of the Sloan catalog for details on these and other Optima Plus Flushometer variations.

**ADA Compliant**

**Automatic**  
Sloan OPTIMA Plus equipped Flushometers provide the ultimate in sanitary protection and automatic operation. There is no need for AC hookups or wall alterations. The Flushometer operates by means of a battery powered infrared sensor. Once the user enters the sensor's effective range and then steps away, the Flushometer Solenoid initiates the flushing cycle to flush the fixture.

**Hygienic**  
User makes no physical contact with the Flushometer surface. Helps to control the spread of infectious diseases.

**Economical**  
Automatic operation provides savings in water usage over other flushing devices. Reduces maintenance and operation costs.

**Warranty**  
3 year (limited)

Made in the U.S.A.

® Listed      @ Listed

Tile information contained in this document is subject to change without notice.

This space for Architect/Engineer approval

Job Name \_\_\_\_\_ Date \_\_\_\_\_

00  
Signature \_\_\_\_\_ Title \_\_\_\_\_

Customer/Wholesaler \_\_\_\_\_  
 Contractor \_\_\_\_\_  
 Architect \_\_\_\_\_

8186  
8186-1.0  
8186-0.5

..... Description  
Exposed, Battery Powered, Sensor Operated Royal Urinal Flushometer.

Flush Cycle

- D Model 8186 Water Saver (1.5 gpf/5.7 Lpf)
- D Model 8186-1.0 Low Consumption (1.0 gpf/3.8 Lpf)
- O Model 8186-0.5 (0.5 gpf/1.9 Lpf)

2Yf MIN.  
(57 mm)

4l  
(121mm)

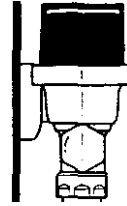

15V2"  
(394 mm)



C/L OF  
FIXTURE

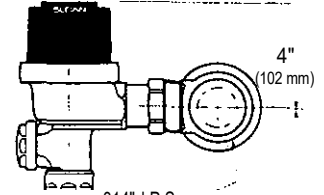

4"  
(102 mm)

3/4" I.P.S.  
SUPPLY  
(ON20mm)

1 1/2"  
(292 mm)



C/L OF  
SUPPLY

ELECTRICAL SPECIFICATIONS

- |  |  |
|--|--|
| ..... Control Circuit<br>Solid State<br>e VOE Input<br>8 sec. Arming Delay<br>24 Hour Sentinel Flush | ..... Battery Type<br>(4) AA Alkaline                            |
| ..... OPTIMA Sensor Type<br>Active Infrared  | ..... Battery Life<br>3 years @ 4,000 flushes/month              |
| ..... OPTIMA Sensor Range<br>Nominal 15"-30" (381-762mm),<br>adjustable ± 8" (203mm)                 | ..... Indicator Lights<br>Range Adjustment/Low Battery           |
|  | ..... Sentinel Flush<br>Once every 24 hours after the last flush |

OPERATION

1. A continuous, invisible light beam is emitted from the TIMA Plus Sensor.

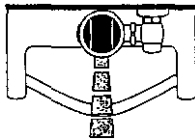

2. As the user enters the beam's effective range (15" to 30") the beam is reflected into the OPTIMA Plus' Scanner Window and transformed into a low voltage electrical circuit. Once activated, the Output Circuit continues in a "hold" mode for as long as the user remains within the effective range of the Sensor.

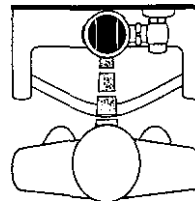

3. When the user steps away from the OPTIMA Plus Sensor, the Sensor initiates an electrical signal that operates the Solenoid. This initiates the flushing cycle to flush the fixture. The Circuit then automatically resets and is ready for the next user.

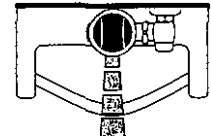

VARIATIONS

DBO  
BEAM  
DEFLECTOR

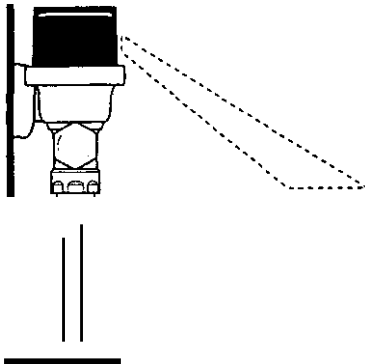

Use when targeting small children and wheelchair users.

DLH  
LESS HANDLE  
OPENING

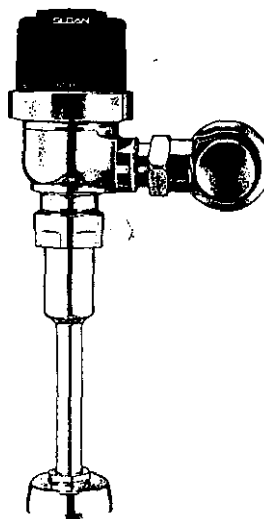

DMC  
METAL COVER

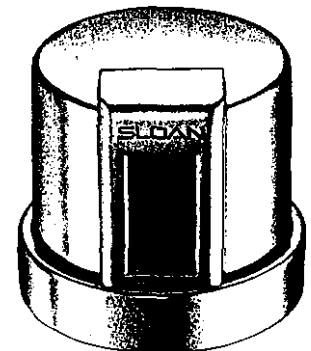



# RESS-C-4.5-MC RESS-C-3.5-MC RESS-C-1.6-MC

- ..... Description  
Battery Powered. Sensor Operated Retro Fit Conversion Kit for Exposed Closet Flushometers.
- Flush Cycle  
 D Model RESS-C-4.5 MC (4.5 gpf/17 LpQ)  
 O Model RESS-C-3.5 MC (Water Saver 3.5 gpf/13.2 LpQ)  
 O Model RESS-C-1.6 MC (low Consumption 1.6 gpf/6.0 LpD)

## ELECTRICAL SPECIFICATIONS

- |  |  |
|--|--|
| ..... Control Circuit<br>Solid State<br>6 vdc Input<br>8 sec. Arming Delay<br>3 second Flush Delay<br>24 Hour Sentinel Flush | Battery Life<br>3 years @ 4,000 flushes/month              |
| OPTIMA Sensor Type<br>Active Infrared  | Indicator Lights<br>Range Adjustment/Low Battery           |
| OPTIMA Sensor Range<br>Nominal 22"-42" (559-1,067mm),<br>adjustable ± 8" (203mm)   | Sentinel Flush<br>Once every 24 hours after the last flush |
| Battery Type<br>(4) AA Alkaline  | Operating Pressure<br>15-100 PSI (104-689 kPa)             |

## OPERATION

Continuous, invisible light beam is emitted from the OPTIMA Plus Sensor.

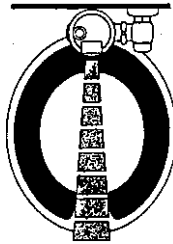

2. As the user enters the beam's effective range (22" to 42") the beam is reflected into the OPTIMA Plus' Scanner Window and transformed into a low voltage electrical circuit. Once activated, the Output Circuit continues in a "hold" mode for as long as the user remains within the effective range of the Sensor.

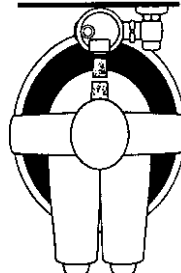

3. When the user steps away from the OPTIMA Plus Sensor, the circuit waits 3 seconds (to prevent false flushing) then initiates an electrical signal that operates the Solenoid. This initiates the flushing cycle to flush the fixture. The Circuit then auto-matically resets and is ready for the next user.



## ROUGH-IN

(on existing Sloan Model 110/111 Flushometer)

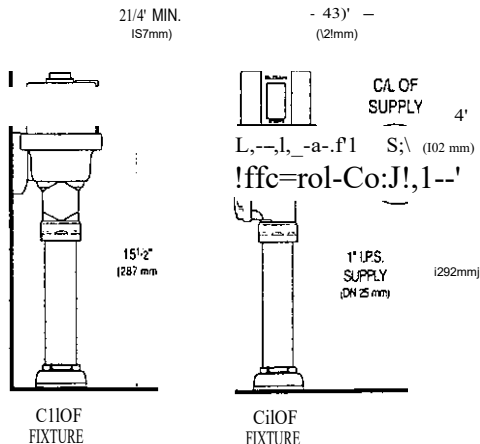

\* Typical Water Supply Rough-in dimensions of existing Sloan Model 110/111 Flushometer.

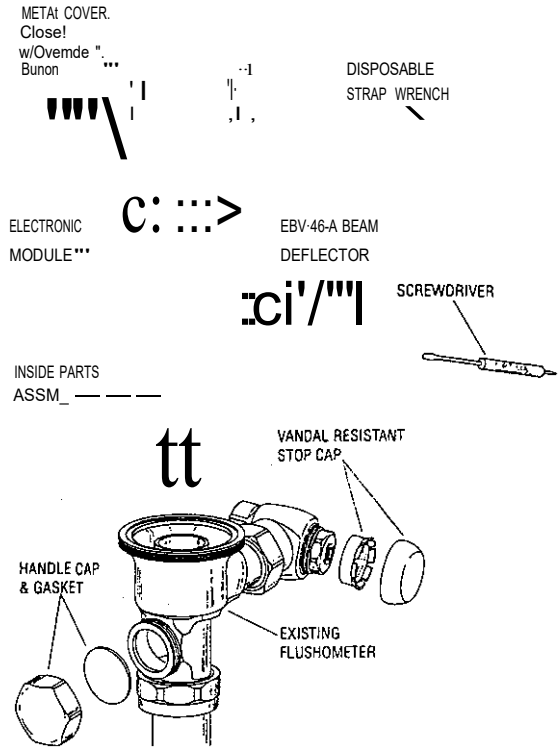

## VARIATIONS

D BO  
BEAM DEFLECTOR

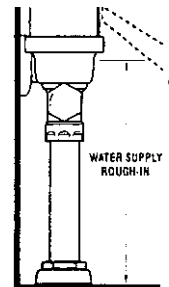

Specify when water supply rough-in is greater than 16" (406 mm) above the top of the bowl.

# SLOAN®

OPTIMA SYSTEMS

# OPTIM

*p'li:u*

Battery Powered Urinal Retro Fit

RESS-U-3.5-MC  
 RESS-U-1.5-MC  
 RESS-U-1.0-MC  
 RESS-U-0.5-MC

**Description**

Battery Powered, Sensor Operated Retro Fit Conversion Kit for Exposed Urinal Flushometers.

**Flush Cycle**

- Ø Model RESS-U-3.5 MC (3.5 gpf/13.2 Lpn
- Ø Model RESS-U-1.5 MC (Water Saver 1.5 gpf/5.7 Lpn
- Ø S. Model RESS-U-1.0 MC (Low Consumption 1.0 gpf/3.8 Lpn
- Ø Model RESS-U-0.5 MC (0.5 gpf/1.9 LpD

**Specifications**

Quiet. Exposed, OPTIMA Plus, Battery Powered, Sensor Operated Urinal Flushometer Retro Fit Conversion Kit for Sloan Royal® and Regal® Flushometers with the following features:

- ADA Compliant OptimaPLLJS™ Battery Powered Infrared Sensor for automatic "No Hands" operation
- Inside Parts Kit with Dual Filtered By-Pass
- Diaphragm to be molded from PERMEX™ rubber compound for Chloramine resistance
- Chrome Plated Die Cast Metal Cover Assembly with Tempered Glass Window
- Four (4) size AA Batteries included
- "Low Battery" Flashing LED
- Infrared Sensor Range Adjustment Screw
- Initial Set-Up Range Indicator Light (first 10 minutes)
- Free Spinning, Vandal Resistant Stop Cap for Sloan H-600 SeriesControl Stop
- Chrome Plated Metal Handle Cap
- Installation Tools provided

**Variations**

- DBO Beam Deflector (for targeting small children and wheelchair users)
- DZ Locking Ring for Zurn! Flush Valve bodies

See Accessories Section and Optima Accessories Section of the Sloan catalog for details on these and other Optima Plus Flushometer variations.

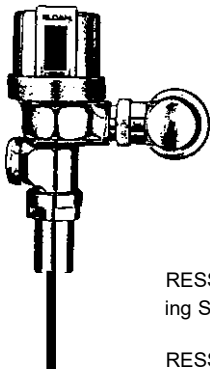

RESS-LI-MC shown installed on an existing Sloan Flushometer.

RESS-LI-MC units do NOT include a Valve Body, Supply Stop, or Vacuum Breaker.

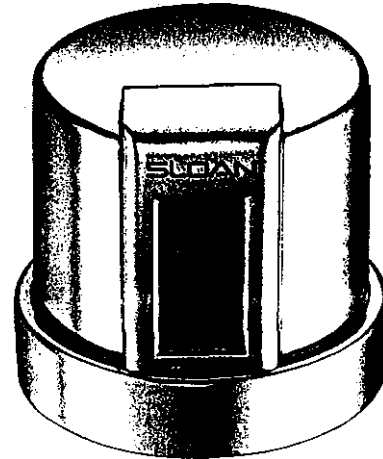

... ADA Compliant

... Automatic  
 Sloan OPTIMA Plus equipped Flushometers provide the ultimate in sanitary protection and automatic operation. There is no need for AC hookups or wall alterations. The Flushometer operates by means of a battery powered infrared sensor. Once the user enters the sensor's effective range and then steps away, the Flushometer Solenoid initiates the flushing cycle to flush the fixture.

Hygienic  
 User makes no physical contact with the Flushometer surface. Helps to control the spread of infectious diseases.

Economical  
 Automatic operation provides savings in water usage over other flushing devices. Reduces maintenance and operation costs.

Warranty  
 3 year (limited)

Made in the U.S.A.

® Listed

® listed

The information contained in this document is subject to change without notice.

This space for Architect/Engineer approval

Job Name: \_\_\_\_\_ Date: \_\_\_\_\_

Model Specified: \_\_\_\_\_ Quantity: \_\_\_\_\_

Variations Specified: \_\_\_\_\_

Customer (Wholesaler): \_\_\_\_\_

Contractor: \_\_\_\_\_

Architect: \_\_\_\_\_

# RESS-U-3.5-MC RESS-U-1.5-MC RESS-U-1.0-MC RESS-U-0.5-MC

## Description

Battery Powered, Sensor Operated Retro Fit Conversion Kit for Exposed Urinal Flushometers.

## Flush Cycle

Model RESS-U-3.5 MC (3.5 gpf/13.2 LpQ)

Model RESS-U-1.5 MC (Water Saver 1.5 gpf/5.7 Lpf)

Model RESS-U-1.0 MC (Low Consumption 1.0 gpf/3.8 Lpf)

Model RESS-U-0.5 MC (0.5 gpf/1.9 Lpf)

## ELECTRICAL SPECIFICATIONS

### Control Circuit

Solid State  
6 VDC Input  
8 sec. Arming Delay  
24 Hour Sentinel Flush

### Battery Type

(4) AA Alkaline

### Battery Life

3 years @ 4,000 flushes/month

### Indicator Lights

Range Adjustment/Low Battery

### Sentinel Flush

Once every 24 hours after the last flush

### Operating Pressure

15-100 PSI (104-689 kPa)

▶ OPTIMA Sensor Type  
Active Infrared

▶ OPTIMA Sensor Range  
Nominal 15"-30" (381-762mm),  
adjustable ± 8" (203mm)

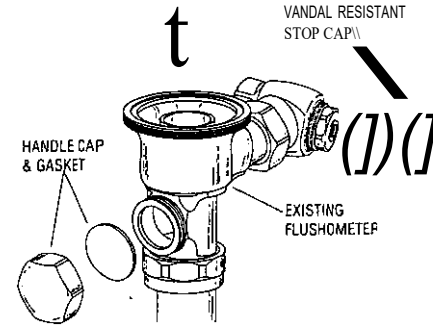
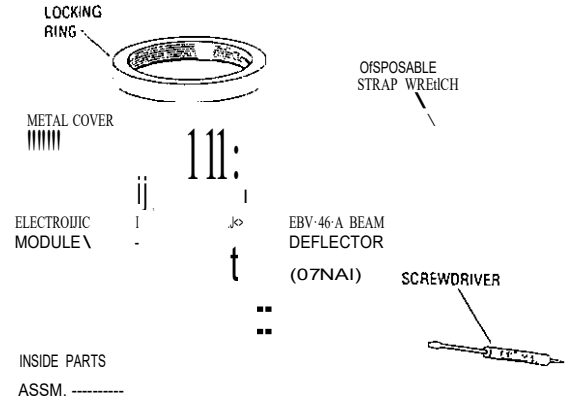

## OPERATION

A continuous, invisible light beam is emitted from the OPTIMA Plus Sensor.

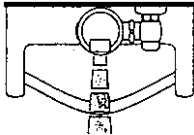

2.

As the user enters the beam's effective range (15" to 30") the beam is reflected into the OPTIMA Plus' Scanner Window and transformed into a low voltage electrical circuit. Once activated, the Output Circuit continues in a "hold" mode for as long as the user remains within the effective range of the Sensor.

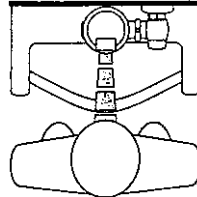

3.

When the user steps away from the OPTIMA Plus Sensor, the Sensor initiates an electrical "one-time" signal that operates the Solenoid. This initiates the flushing cycle to flush the fixture. The Circuit then automatically resets and is ready for the next user.

## ROUGH-IN

(on existing Sloan Model 186 Flushometer)

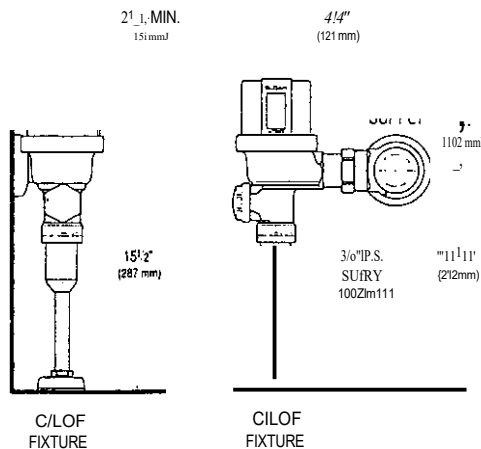

\* Typical Water Supply Rough-in dimensions of existing Sloan Model 186 Flushometer.

## VARIATIONS

DBO  
BEAM DEFLECTOR

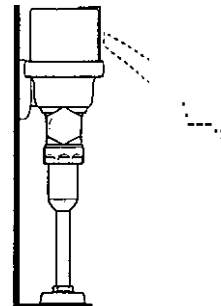

Use when targeting small children and wheelchair users.

WASHBROOK URINAL

- Vitreous china
- Low-consumption (3.8 Lpf/1.0 gpf)
- Flushing rim
- Elongated 14" rim from finished wall
- Washout flush action
- Extended sides for privacy
- 3/4" inlet spud
- Outlet connection threaded 2" inside (NPTF)
- 2 wall hangers
- Fixture only
- Meets ANSI flush requirements at 0.7 to 1.0 GPF

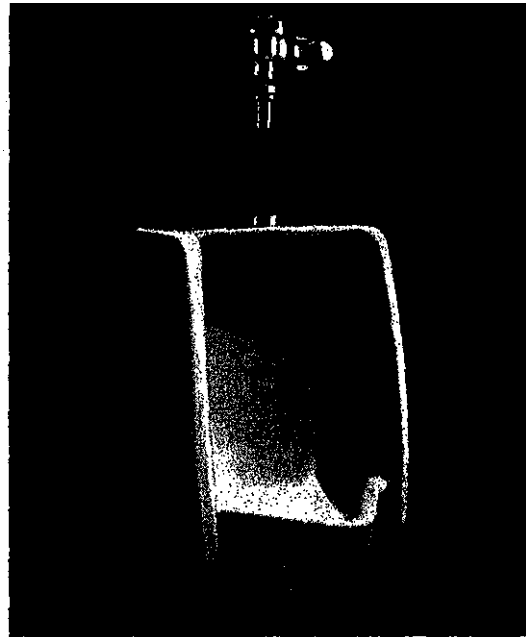

- 0 65010 Top spl.id **MF S Jzicl**
- 0 6506.011 Backspud

Nominal Dimensions:  
 470 x 359 x 692mm  
 (18-1/2" x 14" x 27-1/4")

Recommended working pressure - between  
 20 psi at valve when flushing and 80 psi static.

Compliance Certifications -  
 Meets or Exceeds the Following Specifications:  
 • ASME A 112.19.2M (and 19.5M) for Vitreous  
 China Fixtures - includes Flush Performance,  
 Ball Pass Diameter, Trap Seal Depth and  
 all Dimension

To Be Specified

- 0 Color: Q White Q Bone Q Silver Q Shell  
 Q Black
- 0 Flush Valve: Sloan Royal 186-1 (top spud)  
 Sloan Royal 195-1 (back spud)
- 0 Alternative Flush Valve:
- 0 Stainless Steel Strainer: 04706B-0070A

•When installed so top of rim is 387mm (15-1/4") from finished floor.  
**MEETS THE AMERICAN DISABILITIES ACT GUIDELINES AND  
 ANSI A117.1 ACCESSIBLE AND USEABLE BUILDINGS AND  
 FACILITIES - CHECK LOCAL CODES.**

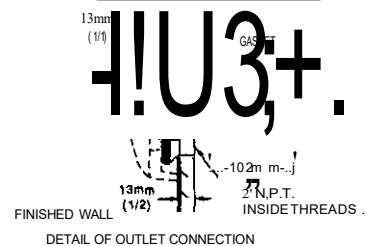
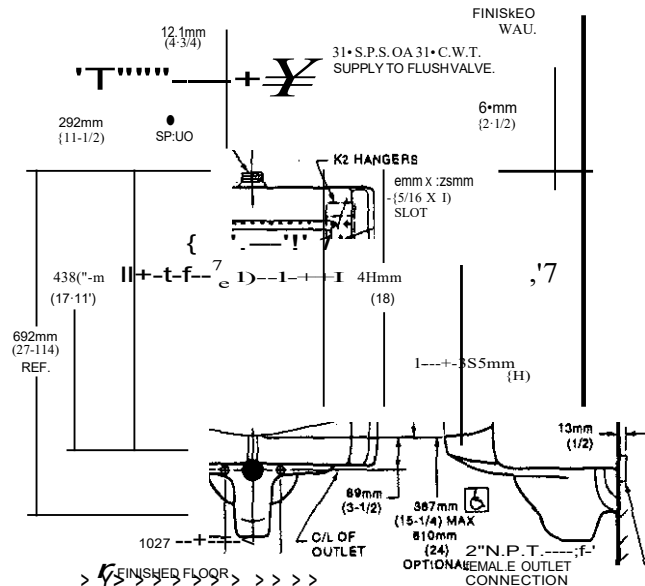

NOTES:  
 FLUSH VALVE NOT INCLUDED AND MUST BE ORDERED SEPARATELY,  
 PROVIDE SUITABLE REINFORCEMENT FOR ALL WALL SUPPORTS.  
 IMPORTANT: Dimensions of fixtures are nominal and may vary within the range of tolerances  
 established by ANSI Standard A 112.19.2.  
 These measurements are subject to change or cancellation. No responsibility is assumed for use  
 of superseded or voided pages.

**BARRIER FREE**

LUCERNE™ WALL-HUNG LAVATORY

- Vitreous china
- Front overflow
- D-shaped bowl
- Self-draining deck area with contoured back and side splash shields
- Faucet ledge

Faucet holes on 203mm (8") centers (Illus.):

- 0356.028 For exposed bracket support  
Shown with .4801.862 Amarelis Heritage faucet with Triune Cross handles (not included)
- 0356.015 For Wall hanger (included) or concealed arms support

Faucet holes on 114mm (4 1/2") centers:

- 0355.02 For wall hanger (included) or concealed arms support

Single center faucet hole (Illus.):

- 0356.041 for exposed bracket support.  
Shown with 1340.000 metering faucet (not included)
- 0356.421 for wall hanger (included) or concealed arms support

Nominal Dimensions:

521 x 464mm (20-1/2" x 18-1/4")

Bowl sizes:

381mm (15") wide, 254mm (10") front to back, 171mm (6-3/4") deep

Compliance Certifications:

Meets or Exceeds the Following Specifications:

- ASME A112.19.2M for Vitreous China Fixtures

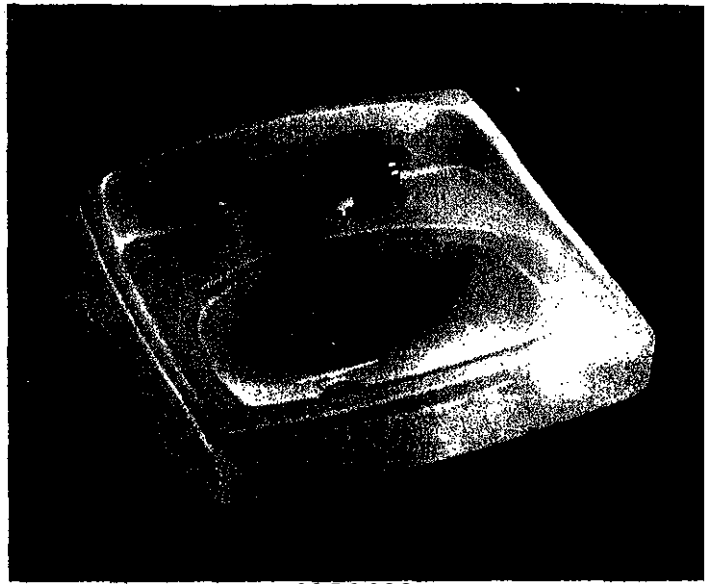

0356,028

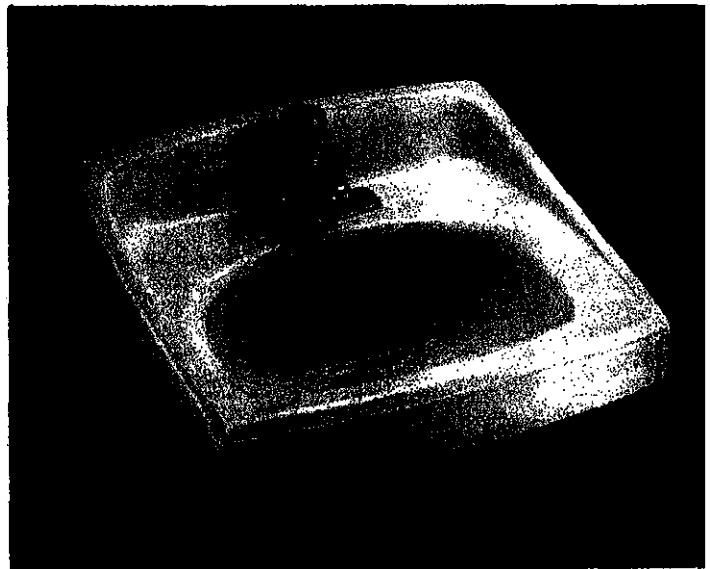

0356.041

To Be Specified

- Color:  White  Bone  Silver  Black
- Shell:
- Faucet:  Faucet Finish:
- Supplies:  1-1/4" Trap:
- Nipple:
- Bracket Support (by others):
- Concealed Arms Support (by others):

**ril** Top of front rim mounted 86Amm (3 1/4") from finished lloOr.  
[Q] MEETS THE AMERICAN DISABILITIES ACT GUIDE-  
LINES AND ANSI A117. † ACCESSIBLE AND USEABLE  
BUILDINGS AND FACILITIES - CHECK LOCAL CODES.

NOTE: Roughing-in information shown on reverse side of page

• See faucet section for additional model & available

P7

**STANDARD SPECIFICATIONS**

These features are common to all Series S19-310 units except where indicated with individual model numbers.

**Shower Head**

10" (254mm) diameter yellow impact resistant plastic or corrosion-resistant stainless steel.

**Shower Valve**

Chrome plated brass 1" IPS stay-open ball valve is operated by stainless steel pull rod with triangular handle (except models S19-310HFP and S19-310NN).

**Eye Wash Bowl**

10" (254mm) diameter yellow impact resistant plastic or corrosion-resistant stainless steel (except models S19-310HFP and S19-310GG-no bowls).

**Sprayhead Assembly**

The integral flow control assures a steady flow under varying water supply conditions.

**Standard**

Chrome plated brass sprayhead assembly with twin, soft flow, eye wash heads and protective sprayhead covers (Models S19-310, S19-310F, S19-310JJ, S19-310LI, S19-310UU, S19-310JIONN, S19-310SC, S19-310DC.)

**Face Spray Ring**

Chrome plated circular spray ring provides supplemental face spray. Flow control assures adequate flow from eye wash nozzles and face spray ring.

**Eye Wash Valve**

Chrome plated 1/2" IPS stay-open ball valve, hand operated by stainless steel push flag handle (except models S19-310AC, S19-310GG, S19-310LL, S19-310UU, and S19-310JIONN).

**Pipe and Fittings\***

1-1/4" galvanized steel protected with Bradco safety yellow coating (except S19-310JJ).

**Water Supply**

1-1/4" IPS

\*NOTE: Models S19-310SC and S19-310SS are all stainless steel

**ADDITIONAL FEATURES**

Available on certain models.

**Hinged Dust Cover**

Stainless steel cover keeps contaminants, dust, and debris from eye washing area.

**Hand or Foot Operated**

Eye wash valve is activated by push flag handle or stainless steel foot pedal. Closes manually by pulling flag handle.

**Eye/Face Wash Spray Head**

Twin perforated disc eye/face wash heads with protective pop-off spray-



Eye Wash

tt

1. D

2. &

Model 519-310  
Plastic Shower Head and Bowl

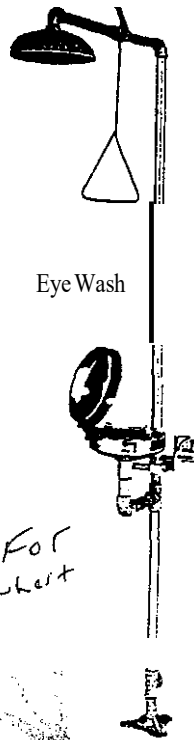

Eye Wash

Use For Leuchert

Model S19-310DOF  
Stainless Steel Hinged Dust Cover and Bowl with Plastic Shower Head

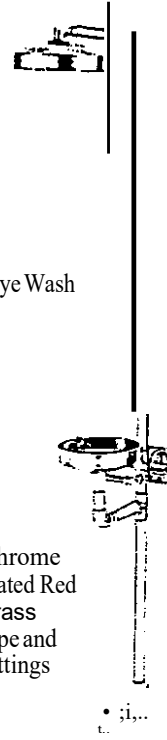

Eye Wash

Chrome Plated Red Brass Pipe and Fittings

Model S19-310JJ  
Stainless Steel Shower Head and Bowl Bright mirror finish is superior in laboratory use and in "J" where appearance is Tant.



Eye/Face Wash Spray Heads

Should be model S19-310DC

Stainless steel cover + bowl with plastic shower head

Keep Eye wash clean in work area see Patrick



Eye/Face Wash

Model S19-310AC  
Plastic Shower Head  
Stainless Steel Bowl  
Hand or Foot Operated

Model S19-310DCR  
Plastic Shower Head  
Stainless Steel Hinged Dust Cover

Model S19-310F  
Stainless Steel Shower Head and Bowl

pn

# Combination SHOWER/EYE WASHES

## Standard Specifications

### Series 519-310

- Shower head - 10" (254mm) diameter yellow impact-resistant plastic or corrosion-resistant stainless steel. Exceeds minimum water flow: 20 GPM at 30 PSI.
- Eye wash bowl - 10" (254mm) diameter yellow impact-resistant plastic or corrosion-resistant stainless steel.
  - Hinged stainless steel dust cover (available on specified models) covers bowl to keep out contaminants and debris from eye wash area. Dust cover opens when handle is activated.
- Sprayhead assembly: All sprayhead assemblies include flow control to 2.55 GPM, steady water flow under varying water supply conditions and pop-off protective sprayhead dust covers.
  - Eye wash features chrome-plated brass soft-flow sprayheads designed to gently cleanse the eyes. Exceeds minimum water flow: .4 GPM at 30 PSI.
  - Eye/face wash features ABS plastic perforated disc sprayheads designed to gently cleanse eyes and face. Exceeds minimum water flow: 3 GPM at 30 PSI.
  - Face spray ring features chrome-plated circular spray ring designed with a wider spray pattern for full face spray.
- Shut-off valve - 1" IPS chrome-plated brass stay-open ball valve is operated by stainless steel pullrod with triangular handle.
- Shut-off valve - 1/2" IPS chrome-plated brass stay-open ball valve is operated by a highly visible yellow, PVC or stainless steel (where specified) push handle.
- Pipe - 1 1/2" galvanized steel pipe (2" for PVC shower) protected with Bradtect™ yellow coating (unless otherwise specified). Includes 9" diameter floor flange (6" for PVC shower).
- Valve - 1/2" supply - 1-1/4" JPS female. 2" IPS (S19-310PVC).
- Valve - 1-1/4" JPS female.
- Compliance - ANSt Z358.1-1998.

CERTIFIED  
MOOELS  
Z358.1-1998

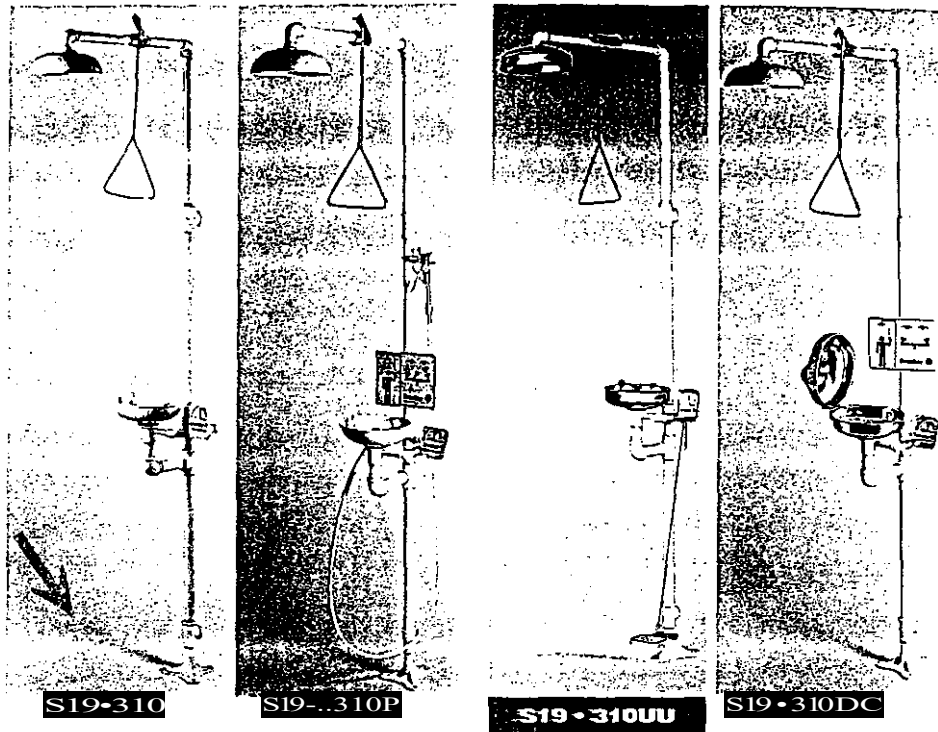

### Shower/Eye Wash

Model S19-310 (shown)  
Plastic shower head and bowl.

Model S19-310P (shown)  
Plastic shower head and bowl. Includes drench hose attachment for face and body rinse.

Model S19-310UU  
Stainless steel shower head and bowl.

Model S19-310DC

All stainless steel fixture.

Model S19-310J

Stainless steel shower head and bowl. Chrome-plated red brass pipe and fittings. Bright mirror finish provided for laboratory use and in areas where appearance is important.

Model S19-310SB

Plastic shower head and stainless steel bowl.

### Shower/Eye Wash

Hand or Foot Operated  
Model S19-310UU (shown)

Stainless steel shower head and bowl.

Model S19-310CLL

Plastic shower head and stainless steel bowl.

### Shower/Eye Wash

with  
Model S19-3100C (shown)  
Plastic shower head, stainless steel hinged dust cover, bowl and push handle.

Model S19-310SC

All stainless steel fixture, hinged dust cover, bowl and push handle.

## Optional Attachments

(All combination models)

Model S19-430EH or S19-430SH

Drench hose spray kit. Available for all combination shower and eye wash models - see page 19.

Model 545-572

Foot treadle kit available for pedestal-mount eye washes and combination drench showers/eye washes - see page 19.

Model 545-620

Foot treadle kit for model S19-310PVC shower only - see page 19.

Standard Insulation

ARMAFLEX  
INSULATION  
SYSTEMS

# AP Armaflex®

SUBMITTAL  
SHEET



## DESCRIPTION

AP Armaflex Pipe Insulation is a flexible elastomeric thermal insulation, black in color, supplied as unslit tubing, in nominal wall thicknesses of 3/8", 1/2", 3/4", and 1", in popular sizes up to 6" IPS. The expanded closed-cell structure of AP Armaflex Pipe Insulation makes it an efficient insulation.

AP Armaflex Pipe Insulation, in 3/8", 1/2", 3/4", and 1" thicknesses has a flame-spread rating of 25 or less and a smoke developed rating of 50 or less as tested by ASTM E 84-91A, "Method of Test for Surface Burning Characteristics of Building Materials."

Numerical flammability ratings alone may not define the performance of products under actual fire conditions. They are provided only for use in the selection of products to meet limits specified.

## USES

AP Armaflex Pipe Insulation is used to retard heat gain and control condensation drip from cold-water plumbing, chilled-water, and refrigeration lines. It also efficiently reduces heat flow for hot-water plumbing and liquid-heating and dual-temperature piping. The recommended temperature usage range for AP Armaflex Pipe Insulation is -70°F to +220°F.

For use on cold pipes, AP Armaflex Pipe Insulation thicknesses have been calculated to control condensation on the insulation outer surface, as shown in the table of thickness recommendations.

## RESISTANCE TO MOISTURE VAPOR FLOW

The closed-cell structure of AP Armaflex Insulation effectively retards the flow of moisture vapor, and AP Armaflex is considered a low-transmittance vapor retarder. AP Armaflex normally requires no supplemental vapor-retarder protection. Additional vapor-retarder protection may be necessary for AP Armaflex when installed on very-low-temperature piping or where exposed to continually high humidity conditions.

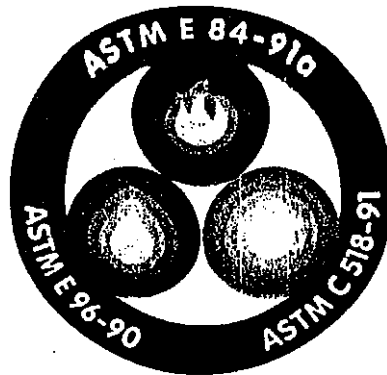

## APPLICATION

AP Armaflex Pipe Insulation in unslit tubular form can be slipped onto piping before it is connected, or it can be slit lengthwise and snapped over piping already connected. Fitting covers are fabricated from miter-cut tubular form. In all cases, butt joints and seams are to be sealed with Armstrong 520 Adhesive. 520 Adhesive is a contact adhesive; therefore, in all cases, both surfaces to be joined are coated with adhesive.

AP Armaflex is designed for installation above ground. Indoors, no protective finish is required. Outdoors, a weather-resistant protective finish is to be applied. The recommended protective finish is Armstrong Armaflex Finish; however, other compatible finish systems are not ruled out.

Armstrong insulation products must be installed according to "Specifications-Installation of Armaflex Insulations," IP-2268. Installation defects and damages in products not installed according to these procedures are not the responsibility of Armstrong.

## SPECIFICATION COMPLIANCE

AP Armaflex can be supplied upon request to meet:

- ASTM D 534, Type I Tubular
- ASTM D 1056, 281
- MIL-C-31330 (MIL STD 6708), Grade SBE 3
- MIL-P-15280J, FORM T

Armstrong

MECHANICAL SYSTEMS INSULATION





ARMSTRONG WORLD INDUSTRIES, INC.  
 INSULATION PRODUCTS  
 P.O. BOX 3001  
 LANCASTER, PA 17604  
 Phone: 717 396 127  
 Fax: 717 396-4265

# AP Armaflex® Pipe Insulation

Physical Properties	Test Method (See note 3)	
Thermal conductivity, Btu • In. Jh • fp • F 75°F mean temp 90°F mean temp	0.27 0.276	ASTM C 177 or E 518
Water vapor permeability, wet cup, perm-in	0.10	ASTM E 96 Procedure B
Water absorption, % by weight	5	ASTM D 1056
Ozone resistance	GOOD	—
Upper use limit, °F (See note 1)	220	—
Lower use limit, °F (See note 2)	-40 (-70)	—
Width thickness, (nominal)	3/8", 1/2", 3/4", 1"	—
Inside diameter, tubular form	3/8" ID to 6" IPS	—
Length of sections, feet, tubular form	6	—

**Notes**

<sup>1</sup>On the healing cycle, AP Armaflex Pipe Insulation will withstand temperatures as high as 220°F. 520 Adhesive may be used with pipe Insulation applications up to 220°F.

<sup>2</sup>At -20°F, flexible AP Armaflex Insulation becomes hard and, as temperatures drop below -20°F, will be increasingly brittle; however, this hardening characteristic does not affect thermal efficiency or water vapor permeability. For applications of 40°F to -70°F, contact Armstrong.

<sup>3</sup>ASTM method, in some cases, may be modified slightly to make results more meaningful for end-use application. If details are required, contact Armstrong.

## ARMAFLEX® PIPE INSULATION THICKNESS RECOMMENDATIONS

For Controlling Outer Insulation Surface Condensation  
 (Based upon available manufactured thicknesses)

Pipe Size	Line Temperatures		
	50°F	35°F	0°F
<b>BASED ON NORMAL DESIGN CONDITIONS*</b> 3/8" ID thru 1-1/8" ID Over 1-1/8" ID thru 2-5/8" ID Over 2-5/8" ID thru 5" IPS	Nom 3/8" Nom 3/8" Nom 1/2"	Nom 1/2" Nom 1/2" Nom 3/4"	Nom 3/4" Nom 1" Nom 1"
<b>BASED ON MILD DESIGN CONDITIONS**</b> 3/8" ID thru 2-5/8" ID Over 2-5/8" ID thru 5" IPS	Nom 3/8" Nom 1/2"	Nom 3/8" Nom 1/2"	Nom 1/2" Nom 1/2"
<b>BASED ON SEVERE DESIGN CONDITIONS***</b> 3/8" ID thru 5" IPS	Nom 3/4"	Nom 1"	Nom 1-1/2"

NOTE: Nom 1-1/2" is multiple-layer application.

\*BASED ON NORMAL DESIGN CONDITIONS AP Armaflex in the thicknesses noted and within the specified temperature ranges will control outer insulation surface condensation indoors under normal design conditions, a maximum severity of 85°F and 70% RH. Armstrong research and field experience indicate that indoor conditions anywhere in the United States seldom exceed this degree of severity.

\*\*BASED ON MILD DESIGN CONDITIONS AP Armaflex in the thicknesses noted and within the specified temperature ranges will control outer insulation surface condensation indoors under mild design conditions, a maximum severity of 50°F and 50% RH. Typical of these conditions are most air-conditioned spaces and arid climates.

\*\*\*BASED ON SEVERE DESIGN CONDITIONS AP Armaflex in the thicknesses noted and within the specified temperature ranges will control outer insulation surface condensation indoors under severe design conditions, a maximum severity of 90°F and 80% RH. Typical of these conditions are indoor areas in which excessive moisture is introduced or in poorly ventilated confined areas where the temperature may be depressed below ambient.

### ALLBROOK® FloWise® 0.5 GPF HIGH EFFICIENCY URINAL SYSTEM

#### 0 6550.501 0.5 gpf Exposed Top Spud Urinal & Manual Piston-Type Urinal Flush Valve

##### URINAL:

- Vitreous china
- High Efficiency (1.9 Lpf/0.5 gpf)
- Flushing rim
- Siphon jet flush action
- 3/4" inlet spud
- Outlet connection threaded 2" inside (NPTF)
- Meets ANSI flush requirements at 0.5 GPF
- Model 6550.001

##### MANUAL FLUSH VALVE:

- Self-cleaning brass piston with integral wiper spring prevents clogging and reduces maintenance
- Piston operation delivers superior flush accuracy and repeatability
- Piston valve remains closed and does not need to be reset after loss of water pressure
- Non-hold open handle
- Positive seal ensures leak-free performance
- No external volume adjustment
- Durable chrome-plated cast brass construction is ideal for commercial applications
- Chloramine-resistant EPDM seals
- Adjustable tailpiece for rough-in flexibility
- Can be installed left or right hand
- Model 6045.051

##### Includes:

- Wall hanger
- 3/4" I.P.S. angle stop with back-flow prevention and vandal-resistant cap
- Sweat solder kit including cover tube and wall flange
- High back pressure vacuum breaker with down tube
- Spud coupling & flange for 3/4" top spud

---

##### To Be Specified:

Color: White

---

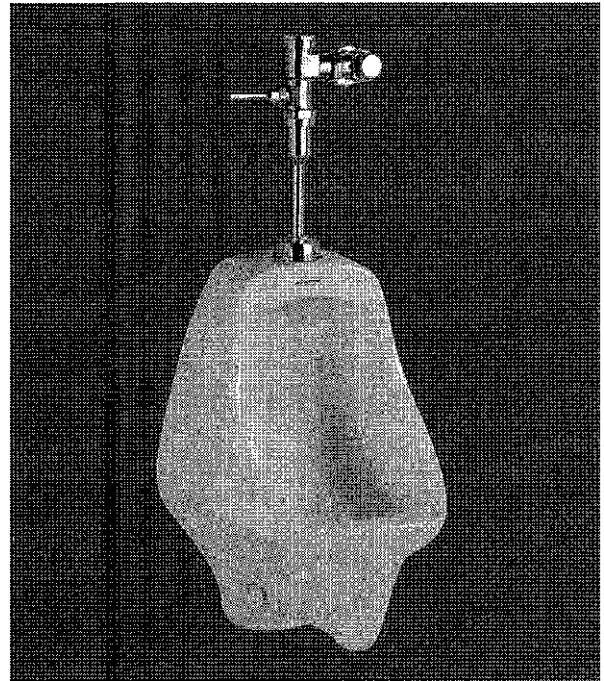

SEE REVERSE FOR ROUGHING-IN DIMENSIONS

##### Operating Pressure:

Overall Range: 20-125 psi.

Recommended: 20 psi (flowing)-80 psi (static)

- Water pressure over 80 psi is not recommended for most plumbing fixtures.

##### Flow Requirement:

10gpm (37.9 L/min.)

##### Nominal Fixture Dimensions:

356 x 363 x 546mm (14" x 14-5/16" x 21-1/2")

##### Fixture Compliance Certifications -

##### Meets or Exceeds the Following Specifications:

- ASME A112.19.2-2008/CSA 845.1-08 for Vitreous China Fixtures

##### Valve Listings:

- ASSE 1037
- ANSI/ASME A112.19.2
- ADA Compliant

**ril** MEETS THE AMERICANS WITH DISABILITIES ACT GUIDELINES  
**LQj** AND ANSI A117.1 ACCESSIBLE AND USEABLE BUILDINGS AND  
FACILITIES - CHECK LOCAL CODES.  
- When installed so top of rim is 432mm (17") from finished floor.



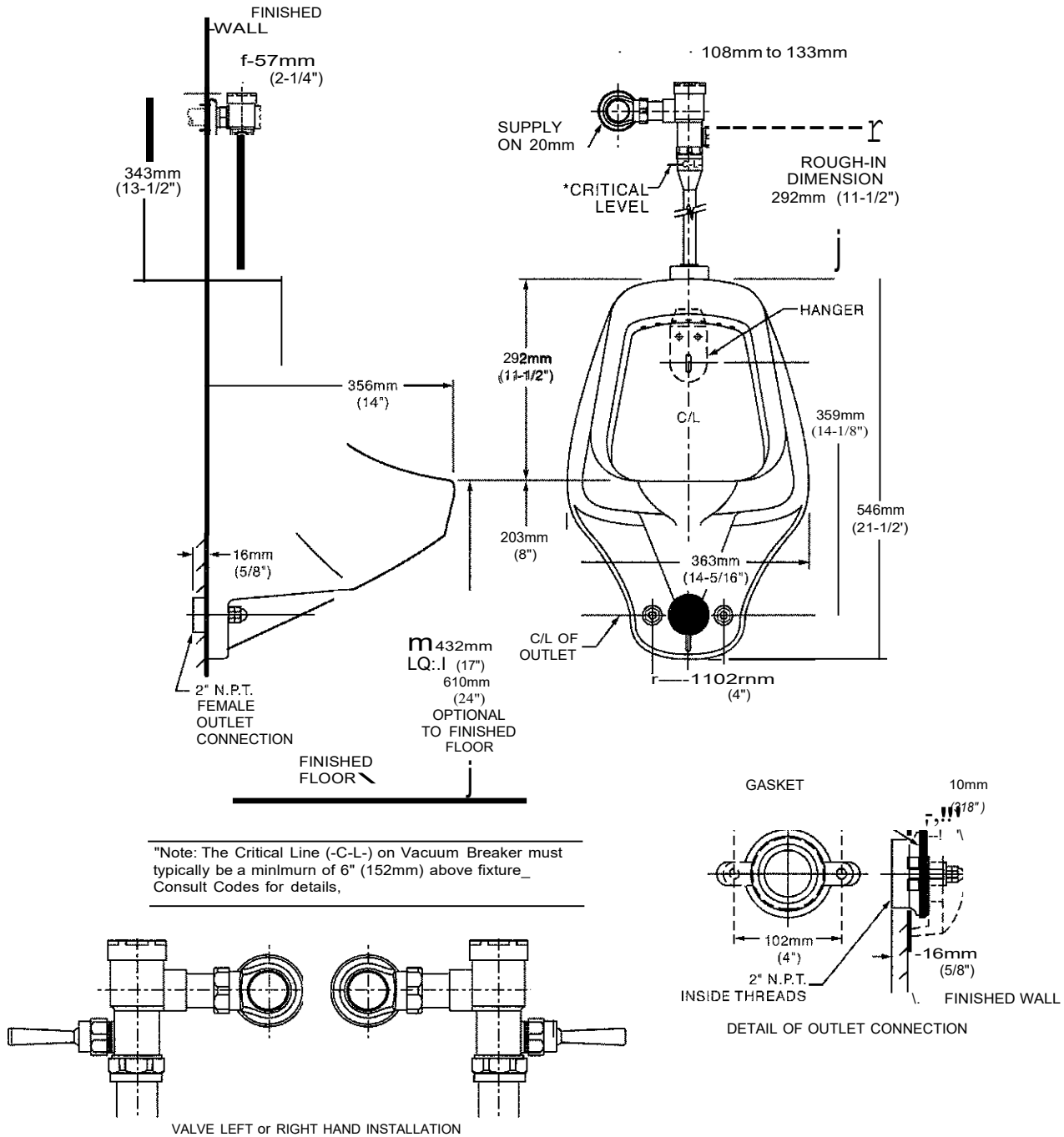

NOTES:  
PROVIDE SUITABLE REINFORCEMENT FOR ALL WALL SUPPORTS.

**IMPORTANT:** Dimensions of fixtures are nominal and may vary within the range of tolerances established by ANSI Standard A112.19.2. These measurements are subject to change or cancellation. No responsibility is assumed for use of superseded or voided pages.



BARRIER FREE

# AFWALL® MILLENNIUM™ FloWise® ELONGATED FLUSHOMETER TOILET VITREOUS CHINA with EVERCLEAN®

## AFWALL® MILLENNIUM™ FloWise® ELONGATED FLUSHOMETER TOILET with EVERCLEAN®

- Wall-mounted flushometer valve toilet
- Vitreous china
- High Efficiency, Low Consumption. Operates in the range of 1.1 gpf to 1.6 gpf (4.2 Lpf to 6.0 Lpf)
- Meets definition of HET (High Efficiency Toilet) when used with a high efficiency flush valve (1.1 gpf - 1.6 gpf or 1.28/1.1 gpf dual flush)
- Maximum Performance (MaP) score of 1,000 grams at 1.1 gpf - 1.6 gpf
- Permanent EverClean® antimicrobial surface inhibits the growth of stain- and odor-causing bacteria, mold, and mildew on the surface
- Condensation channel
- Concealed trapway design
- Elongated bowl
- Powerful direct-fed siphon jet action
- 1-1/2" inlet spud
- Fully-glazed 2-1/8" trapway
- 10" x 12" water surface area
- Static weight load of 1,000 lbs:
- 100% factory flush tested

- 3351.101 Elongated bowl only, top spud
- 3352.101 Elongated bowl only, top spud with slotted rim for bedpan holding
- 3353.101 Elongated bowl only, back spud
- 3354.101 Elongated bowl only, back spud with slotted rim for bedpan holding

### System MaP\* Score:

- 1,000 grams of miso @ 1.1 gpf to 1.6 gpf when used with an American Standard flush valve

\* Maximum Performance (MaP) testing performed by IAPMO R&T Lab. MaP Report conducted by Veritec Consulting, Inc. and Koeller and Company.

### Component Parts:

- 047007-0070A Inlet Spud (furnished with bowl)

### Nominal Dimensions:

660 x 356 x 381mm  
(26" x 14" x 15")

Recommended working pressure-between  
25 psi at valve when flushing and 80 psi static

Fixture only, less seat, bolt caps, and  
flushometer valve

### Compliance Certifications -

Meets or Exceeds the Following Specifications:

- ASME A112.19.2/CSA 845.1 for Vitreous China Fixtures

\* This product is not recommended for bariatric use.

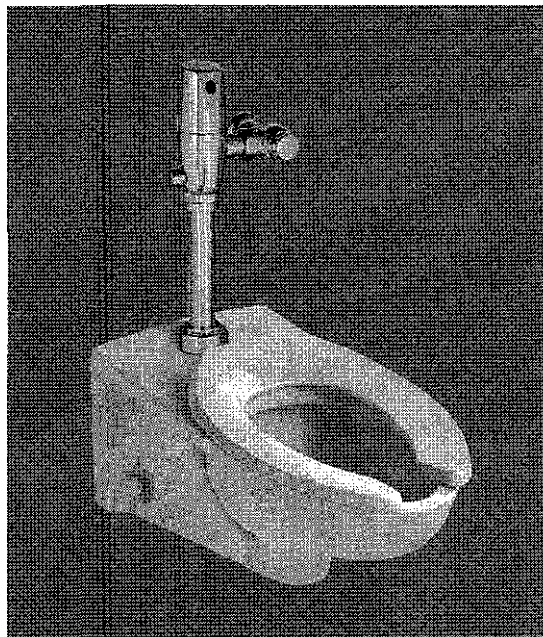

SEE REVERSE FOR ROUGHING-IN DIMENSIONS

### To Be Specified:

- Color: ○ White
- Seat:
  - J American Standard #5901.100 Heavy duty open front less cover
  - CI American Standard #5905.100 Extra heavy duty open front less cover
- CI Flushometer Valve:
  - 1.6 gpf:
    - IJ Sensor-Operated: American Standard Selectronic® DC Power #6065.161.002 (Top Spud)  
AC Power #6067.161.002 (Top Spud)
    - 0 Manual: American Standard #6047.161.002 (Top Spud)
  - 1.28 gpf:
    - 0 Sensor-Operated: American Standard Selectronic® DC Power #6065.121.002 (Top Spud)  
AC Power #6067.121.002 (Top Spud)
    - 0 Manual: American Standard #6047.121.002 (Top Spud)
  - 1.6 / 1.1 gpf Dual Flush:
    - 0 Sensor-Operated: American Standard Selectronic® DC Power #6065.761.002 (Top Spud)  
AC Power #6067.761.002 (Top Spud)
  - 1.28 / 1.1 gpf Dual Flush:
    - D Sensor-Operated: American Standard Selectronic & DC Power #6065.721.002 (Top Spud)  
AC Power #6067.721.002 (Top Spud)

MEETS THE AMERICANS WITH DISABILITIES ACT GUIDELINES AND ANSI A117.1 REQUIREMENTS FOR ACCESSIBLE AND USABLE BUILDING FACILITIES CHECK LOCAL CODES.

- When installed so top of seat is 432 to 483mm (17" to 19") from the finished floor.

## EVERCLEAN®



3351.101/3352.101

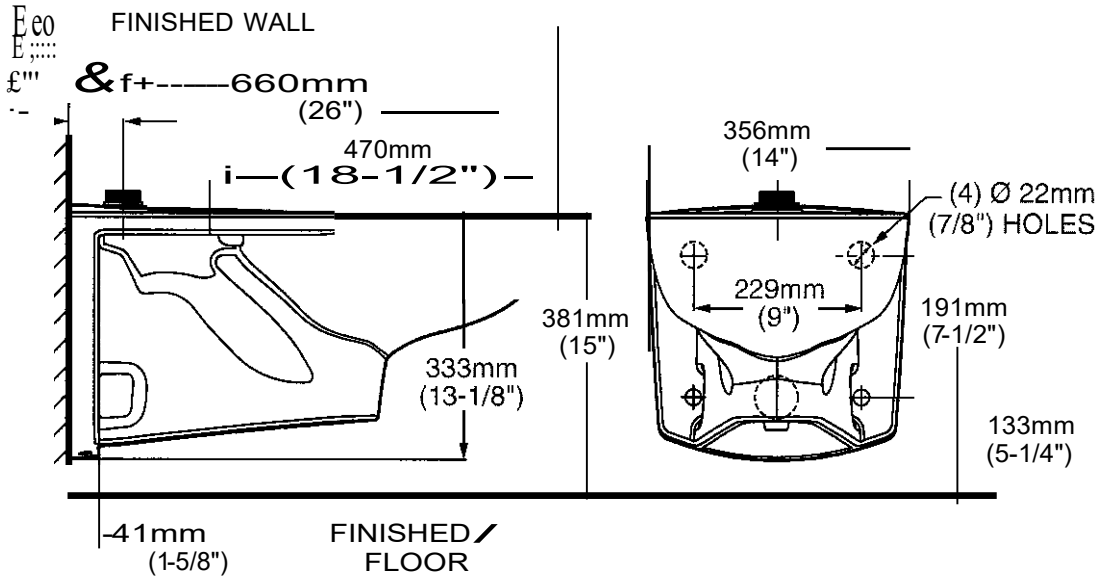

3353.101/3354.101

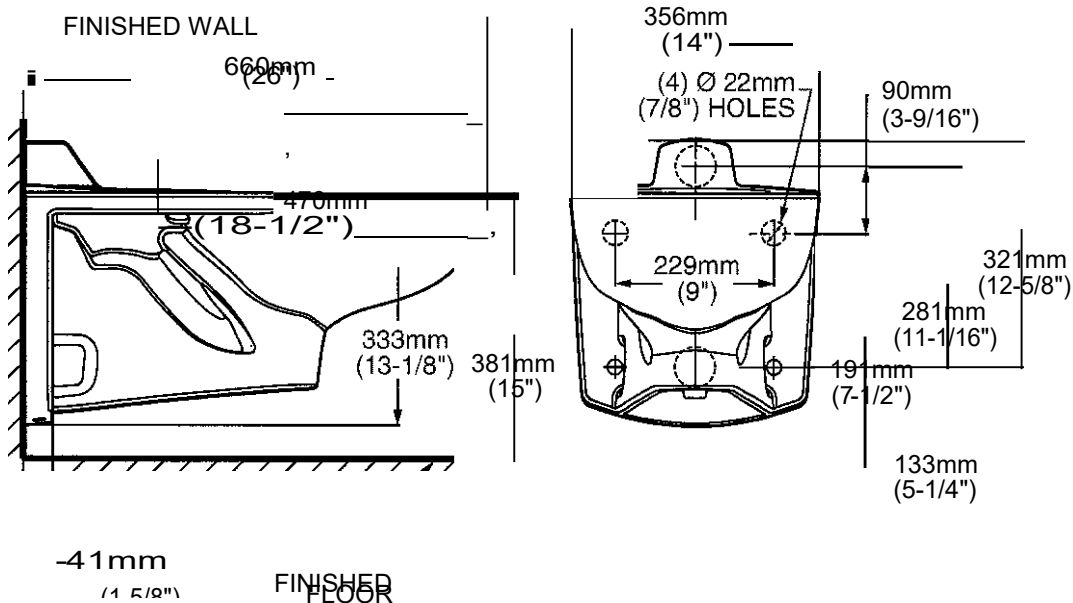

**NOTES:**

• Toilet designed to meet ADA accessibility standards when top of seat height set at 432 to 483mm {17" to 19"} from finished floor.

PRODUCT 3351 AND 3353 SHOWN, 3352 AND 3354 SAME EXCEPT WITH SLOTTED RIM FOR BED PAN HOLDING.

**WASTE OUTLET SEAL RING MUST BE NEOPRENE OR GRAPHITE FELT (WAX RING NOT RECOMMENDED).**

SUGGESTED 2mm (1/16) CLEARANCE BETWEEN FACE OF WALL AND BACK OF BOWL.

TO COMPLY WITH AREA CODE GOVERNING THE HEIGHT OF VACUUM BREAKER ON THE FLUSHOMETER VALVE, THE PLUMBER MUST VERIFY DIMENSIONS SHOWN FOR SUPPLY ROUGHING.

FLUSHOMETER VALVE NOT INCLUDED WITH FIXTURE AND MUST BE ORDERED SEPARATELY.

CARRIER FITTING AS REQUIRED TO BE FURNISHED BY OTHERS.

PROVIDE SUITABLE REINFORCEMENT FOR ALL WALL SUPPORT.

**IMPORTANT:** Dimensions of fixtures are nominal and may vary within the range of tolerances established by ANSI Standard A112.19.2. These measurements are subject to change or cancellation. No responsibility is assumed for use of superseded or voided pages



rlwin

hN-09-01 TUE 12:05 PM

WSC HARRISSBURG

FAX: 71 72331 910

PAGE 4

# Delta® Single-Handle Lavatory Faucets

- 2 1/2" 3 hole install
- 4 1/2" long spout
- 2.0 gpm @ 60 psi
- 7.1 gpm @ 414 kPa

P!

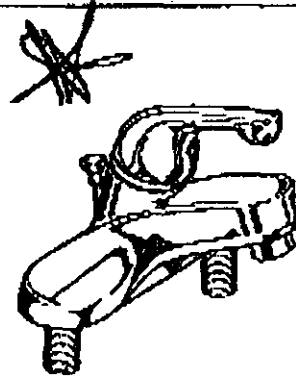

POP-UP DRAIN

Chrom	Chrome	Chrome	Chrome	Chrome	Chrome
95.15	99.10	95.15	99.10	107.00	107.00
6	6	6	6	6	6

Chrome
525-MPU
Metal
129.20
6

PRICE QUANTITY

# STERLI 1'

A KOHLEI

CUR - OU  
SELF-RI  
PLANTIL  
LAVABO  
GABARIT  
LAVABO  
SANIBEL  
SANIBEL<sup>1</sup>

15-15116"  
(40.5 cm)

18-9/16"  
(47.1 cm)

IMPORTANT:  
IMPORTANT£:  
IMPORTANT:

The  
must

SIZE:  
Metric

Dimensions match the dimensions

Size:  
Metric

asegurese de que las dimensiones  
en con las dimensiones marcadas en la plantilla.

Size:  
Metric

chelle, s'assurer que les dimensions  
ent avec les dimensions sur le gabarit.



REMARQUE : AVANT DE COUPER !  
POUR LES POIGNEES



TERLINGO®

A KOHLER COMPANY

CUT-OUT TEMPLATE  
SELF-RIMMING LAVATORY  
PLANTILLA DE RECORTE  
LAVABO CON BORDE TERMINADO  
GABARIT  
LAVABO À REBORD INTEGRE  
SANIBEL™ 442004- \* @  
SANIBEL™ 442008- • • - @

15-15/16"  
(40.5 cm)

1e dimensions

1<sup>as</sup> dimensiones  
mes marcadas en la plantilla.

1<sup>as</sup> que les dimensions

1

**SECTION 120240  
DISINFECTION OF WATER LINES**

**PART 1 - GENERAL**

**1.1 Description**

- A. Work covered by this Section includes the disinfection of water lines. Any water line which is installed or any water line which is broken into, repaired or replaced shall be flushed and disinfected. Such conditions include, but are not limited to, the following:
  - 1. New Water Mains.
  - 2. New Water Services.
  - 3. Water lines adjacent to points where new hydrants, meters, valves or other appurtenance have been added to an existing water main or service, including the inserted device.
  - 4. New plumbing systems.
  - 5. Portions of existing water mains and services which have been damaged, broken, replaced, repaired or suspected of being contaminated as a result of construction operations.
- B. Definition - "Standard Methods" means the publication "Standard Methods for the Examination of Water and Wastewater," American Public Health Association, latest edition.
- C. All flushing, sampling and testing shall be witnessed by Messiah University 48 hours' notice is required prior to any of this work.

**1.2 Quality Assurance**

- A. Provide at least one person who shall be present at all times during the execution of this portion of the Work and who is thoroughly familiar with the procedures and methods specified and who shall direct all work performed under this Section.
- B. Comply with all pertinent procedures and requirements of AWWA C651, Federal State and Local laws, regulations and ordinances.
- C. Flushing velocity shall not be less than 2.5 ft./sec.
- D. Flushing of lines shall be done in an approved manner and shall not cause damage to property and structures, nor cause any interference with pedestrian or vehicular traffic.
- E. All laboratory testing shall be performed by one of the following:
  - 1. State Health Department.
  - 2. An approved testing laboratory.
  - 3. Owners laboratory.
  - 4. Contractor (free chlorine residual only - with approved test apparatus).

F. AWWA Standards C651 are made part of these specifications (attached).

1.3 Submittals

- A. Proposed methods and procedures for flushing and disinfecting.
- B. Lab Test results as required under Paragraph FIELD QUALITY CONTROL.
- C. Final certification that all required disinfection has been completed.
- D. Letters of approval from all applicable authorities and utility companies.

PART 2 - PRODUCTS

2.1 Materials

- A. Equipment used during the disinfection of water lines shall be compatible with the form of chlorine used and as recommended by AWWA C651.
- B. Liquid Chlorine - AWWA B301.
- C. Hypochlorites - AWWA B300.
  - 1. Calcium Hypochlorite
  - 2. Sodium Hypochlorite
- D. Sampling Taps - As suggested in AWWA C651.
- E. No granular or tablet allowed.

2.2 Mixes

- A. Chlorine solution shall be of adequate strength to obtain the required chlorine concentration recommended in AWWA C651.

PART 3 - EXECUTION

3.1 Preparation

- A. Prearrange and provide for proper drainage and disposal of the highly chlorinated water used during disinfection and water used for flushing.
- B. Provide feeders, mixers, applicators, sampling taps and other devices required to admit and discharge the flushing water and the chlorine.

3.2 Performance

- A. Thoroughly clean and flush pipes before disinfecting.

- B. Disinfect pipe by one of the methods recommended in AWWA C651 (except Tablet Method Section 5.1).

3.3 Field Quality Control

- A. Perform tests and collect samples in accordance with "Standard Methods".
- B. Collect samples at points indicated in AWWA C651 and where directed by Owner. For plumbing systems, collect samples from at least four individual faucets located on various branches in the system. Take care not to contaminate samples.
- C. Conduct chlorine residual tests to verify that the proper strength chlorine solution is being utilized and that the stipulated chlorine residual is being attained.
- D. Perform Total Coliform tests. If the tests are positive, then re-disinfect the pipe until the tests show an absence of coliform organisms.

3.4 Protection

- A. Protect all disinfected lines from contamination.
- B. Repeat disinfection process on lines that become or may have become re-contaminated and on all lines in which coliform bacteria were found.

\*\* END OF SECTION \*\*

**SECTION 120250  
PIPE LEAKAGE TESTING**

**PART 1 - GENERAL**

- 1.1 Description
- A. This Section covers the requirements for performing leakage tests on pipelines and appurtenances, and is one of the several bases for acceptance of the Work.
  - B. All pressure pipes, non-pressure pipes and appurtenances shall be tested for leakage.
  - C. Definitions:
    - 1. Leakage (or ex-filtration) - The quantity of water to be supplied into the newly laid pipe, any valved section thereof, or other appurtenance, necessary to maintain the specified leakage test pressure after the pipe has been filled with water and the air expelled.
    - 2. Infiltration - The quantity of water which enters into any pipe, or other appurtenance when the static groundwater elevation is at the minimum elevation above the pipe or appurtenance as specified hereinafter.
  - D. All leakage, ex-filtration, infiltration, air and vacuum testing shall be witnessed by Messiah University. 48 hours' notice is required prior to this work being performed.
- 1.2 Quality Assurance
- A. Prior to final acceptance of the Work, all pressure pipes, non-pressure pipes, and appurtenances shall meet specific leakage requirements. These leakage requirements must be satisfied by the basic materials alone. Where joint fillers and the like have been specified, primarily to protect jointing materials, and secondarily to provide a factor of safety, they shall not be applied until after leakage tests have been completed.
  - B. Every test must be witnessed by Owner and any test not so witnessed will be considered as not having been performed. Contractor shall pretest the Work and shall not request Owner to witness the final test until he is reasonably certain that the test will yield results within the acceptable limits.
  - C. No work shall be closed or covered up until it has been duly inspected and approved for proper and satisfactory construction and installation, and compliance with Plans and Specifications. Should incomplete or unapproved work be covered, the Contractor shall, at his own expense, uncover all work so that it may be properly inspected and approved. After such inspection and approval, he shall properly repair and replace all work found defective, unsatisfactory, and not in accord with the Plans and Specifications, and after such repair and replacement, he shall bring all work to the completeness and status as it was before it was closed and covered, all at his own expense.

- D. Successful completion of required tests shall be in no way interpreted as relieving the Contractor of responsibility for defects which become apparent subsequent to the time of testing. It shall be the sole right of the Owner to determine whether defects exist and the Contractor shall retest all portions of the Work deemed necessary by the Owner prior to final approval of the Project.
- E. If defects, leaks, infiltration, or other unacceptable conditions are present or suspected to be present, the Owner may order television inspection of the completed lines in question. Such television inspection shall be performed by the Contractor, solely for the purpose of locating defects, and to minimize the amount of re-excavation necessary to properly locate defects, and effect repairs. No additional compensation will be allowed for television inspection, if ordered, it being understood and agreed that such tests will be ordered only as specified herein and that, if ordered, the costs associated therewith will have been included in the various unit and lump sum prices as bid in the Proposal for the Work.

### 1.3 Submittals

- A. Complete details and specifications on testing apparatus.
- B. Certified test results on forms approved by Owner. Samples of acceptable forms are attached to this Section.

### 1.4 Sequencing and Scheduling

- A. Notify Owner at least 48 hours in advance of a scheduled test so that the test may be witnessed.
- B. Test the first 300' of underground gravity sewer as soon as the pipe is laid and prior to backfilling.
- C. Test the first 300' of underground gravity sewers each time a different type of pipe has been used as soon as the pipe is laid and prior to backfilling.
- D. Test the first 300' of underground pressure piping as soon as the pipe is laid and prior to backfilling.
- E. Test the first section of pipe in which there is an adaptor, coupling, lateral connection or other pipe specialty or fitting as soon as pipe is laid and prior to backfilling.
- F. At Owner's discretion, additional sections of pipelines may be required to be tested as soon as pipe is laid and prior to backfilling when working conditions or the standard of workmanship have been altered.
- G. The tests required above in Paragraphs B,C,D,E and F are considered trial tests and only serve the purpose of checking the acceptability of the type of pipe, joint and appurtenances being used and the competence of workmanship of the Contractor's crew in installing them. Successful installation of these first sections will be a prerequisite to further installation by the crew or of the materials.
- H. If any trial test does not fulfill the test requirements, cease installations until the reasons

for failure are determined, the conditions rectified, and the test rerun and satisfactorily passed.

- I. Each trial tested section shall be retested after the backfilling operation is completed before acceptance of the work can be given by Owner.
- J. All testing of underground piping shall be kept current and shall closely follow the work in progress. The maximum permissible period of time between installation and passing the required tests shall be 3 weeks.
- K. All piping shall be tested after all connections, pressure gauges, thermometers and other permanent appurtenances have been installed, except where test pressure may damage them.
- L. No piping shall be insulated, concealed or furred in until it has passed all tests.
- M. Conduct tests on sections of pipe lines between adjacent manholes, valves or chambers as determined by Owner.

## PART 2 - MATERIALS

### 2.1 Testing Apparatus

- A. Provide all labor, pumps, plugs, measuring equipment and other apparatus, complete, and as required to perform all testing.
- B. Provide clean water, air, nitrogen and other materials as required to accomplish all testing.
- C. Provide plugs and caps capable of withstanding the test pressures.
- D. Provide all temporary flanges, plugs, bulkheads, thrust, blocks, weighing, bracing and other items necessary to prevent joints from separating, and to prevent any injuries or damage.

## PART 3 - EXECUTION

### 3.1 Preparation

- A. Pipe Displacement Tests - Provide pipe displacement tests prior to performing leakage tests.
- B. Bracing Pressure Piping - Plug open ends, adequately block bends, tees, ends, and other fittings, and do whatever is necessary to brace the piping system so that it will safely withstand the pressures developed under the tests and so that no damage or injury will occur to the pipeline, people or property.
- C. Protection - Before tests are conducted, isolate or remove any regulator, gauge, trap, or other apparatus or equipment which may be damaged by test pressures.

### 3.2 General

- A. Trapped Air - Trapped air may cause a false indication of the rate of leakage. Points of concern include ends of lines, stubs, lateral connections and high points in pipelines. No credit will be made for this condition and no adjustment will be made to the allowable leakage. Where trapped air is suspected of causing a test failure, do whatever is necessary to evacuate the air and repeat the tests until the actual leakage is equal to or less than the allowable rate of leakage.

3.3 Tests for Non-Pressure Piping (Except Storm Drains)

A. General

1. Air testing is permitted.
2. Leakage testing shall include the main non-pressure pipe, lateral connections, and all other appurtenances on the section of pipeline being tested.
3. Adequately plug ends of all lateral connections, stubs and all other openings from which air may escape.
4. Determine groundwater levels by installing test holes or test pits at intervals not to exceed 1,000'.

B. Vertical Deflection - All PVC gravity sewers shall be tested for vertical deflection.

C. Air Testing of PVC Sanitary Sewer

1. The Contractor shall submit details of air testing procedures to the Owner for approval.
2. Air testing is to be used for line acceptance; corroborative hydrostatic testing shall be performed on sewer installations of the same pipe size, material and conditions of installation. Sewer sections which indicate the rates of air loss per unit of surface area which most nearly approximate the rate for pipeline acceptance should be selected for the corroborative tests. At least three (3) sections are to be so tested.
3. If the air test is not supported by acceptable corroborative hydrostatic tests, complete hydrostatic testing of the sewer lines shall be required as the basis for final pipeline acceptance, in a manner acceptable to the Owner.
4. As a safety precaution, pressurizing equipment should include a regulator set at 8 psi to avoid over-pressurizing and damaging an otherwise acceptable line.
5. A satisfactory test shall require a time period in excess of that listed in the Table below.
6. The Contractor shall also provide a separate certified test gauge for periodic checking of the accuracy of the basic equipment gauges.
7. The maximum allowable leakage in the sewer lines shall be 100 gal/mi/24 hr. per inch of internal diameter of the sewer.
8. Air test minimum requirements

Minimum Holding Time in minutes required for pressure to drop  
1.0 PSIG Pipe

4" Diameter	2-1/2 Minutes
6" Diameter	4 Minutes



8" Diameter	5 Minutes
10" Diameter	6-1/2 Minutes
12" Diameter	7-1/2 Minutes
15" Diameter	9-1/2 Minutes

### 3.4 Tests for Pressure Pipes

#### A. General

1. Leakage testing shall include the main pressure pipe, service connections, and all other appurtenances on the section of pipeline being tested.
2. All pipes shall be tested prior to applying insulation and before they are concealed or furred-in.
3. Provide all necessary gauges. Gauges shall be standard pressure type with a minimum 6" diameter dial and a pressure range not in excess of 50% of the maximum required test pressure.
4. Provide and maintain at the site a gauge stand with an approved laboratory calibrated test gauge. Periodically check test gauges used for testing against the test gauge, and whenever requested by Owner.
5. Where it is absolutely necessary for testing, tap pipes and insert approved plugs after testing is completed.
6. Provide a hand or motor driven pump to maintain the required test pressure constant throughout the duration of the test. If a water pump is used, pump water from a container with a known volume of water. If an air or inert gas pump is used, leakage shall be determined and calculated by the cycling of the pump.

#### B. Underground Pipes

1. Conduct leakage test in accordance with AWWA C600.
2. Tests may be performed with trench partially or totally backfilled.

#### C. Pipes Carrying Gases

1. In order to secure more accurate test results, allow ample time for the temperature of the gas and piping to stabilize.
2. Provide concentrated liquid soap or a commercial leak detection preparation and use for locating leaks on exposed piping.

### 3.5 Tests for Storm Drains and Drainage Structures

- A. Structures - Leakage testing of drainage structures is not required. However, visible infiltration into structures is not permitted and shall be stopped when it is found to exist.
- B. Culverts - Leakage testing of culverts is not required, provided that manufacturer provides a certification that pipe and joints have satisfactorily passed factory hydrostatic testing as prescribed in the applicable pipe standards.
- C. Storm Sewers - Leakage testing of storm sewers is not required. However, visible infiltration into storm sewers is not permitted and shall be stopped when encountered.

### 3.6 Allowable Leakage

- A. It is the intent of this Contract to secure piping systems with leakage, in each section of pipe and within each structure, equal to, or less than that specified. It is also the intent to secure a piping system free from visible drips, streams, and leaks. Therefore, even if a portion of the system meets the requirements for allowable leakage, visible leaks are not permitted and shall be stopped.
- B. Leakage tests will be considered satisfactorily passed when the rate of leakage is equal to or less than the stipulated allowances, there is no evidence of visible leaks, and there is no evidence of other system defects.

3.7 Retesting

- A. Pipes not passing the tests shall have all defects corrected to the satisfaction of Owner, and shall be re-tested and re-corrected as often as is necessary until the test requirements have been met.
- B. It is the intent of this Contract to obtain work meeting test requirements on their own and solely through the use of the normal integral sealing components. Joint leaks shall not be stopped through the use of concrete, caulking, mortar, or other patching materials. Leaking pipe joints shall be rejoined or replaced if necessary.
- C. Methods other than rejoining, resetting or replacing joint seals shall require the written approval of Owner.

3.8 LEAKAGE TESTING REQUIREMENTS

----- TEST -----	ALLOWABLE LEAKAGE <sup>(1)</sup>				
Gas or	Duration				
ITEM TESTED	Fluid	Pressure	(Time)	Infil	Exfil Exposed
NON-PRESSURE PIPING - SANITARY					
4" Diameter SDR 35 PVC	Air	4 PSI	2.5 Min.	0	1 PSI
6" Diameter SDR 35 PVC	Air	4 PSI	4 Min.	0	1 PSI
8" Diameter SDR 35 PVC	Air	4 PSI	5 Min.	0	1 PSI
10" Diameter SDR 35 PVC	Air	4 PSI	6.5 Min.	0	1 PSI
NON-PRESSURE PIPING - DRAINAGE					
Storm Sewers				----- No Limit -----	
PRESSURE PIPING					
Water Lines	Water	X <sup>(2)</sup> 3 Hrs.	0	X <sup>(2)</sup>	0
Water Lines (Fire)	Water	X <sup>(3)</sup> 3 Hrs.	0	X <sup>(3)</sup>	0
STRUCTURES					
Drainage Structures No Visible Leakage					

----- NOTES -----

1. Maximum allowable leakage in gallons / day / inch diameter / mile of pipe, or gallons / day / inch diameter/vertical foot for manholes. Where a percentage is shown, the loss shall not exceed the percentage of the starting test pressure.
2. When pipe has been backfilled, test pressure shall be 50% above the normal operating pressure and shall also meet all requirements of Section 4 of AWWA Specification C-600.
3. When pipe has been backfilled, test pressure shall be 50% above normal operating pressure or 200 PSI, whichever is greater, and shall also meet NFPA-13.

WATER MAIN PRESSURE/LEAKAGE TEST

- A. Location/Description of Line Being Tested
- B. Testing Station Elevation
- C. Maximum Elevation of Line Tested
- D. Elevation Differential
- E. Gage Correction @ Testing Station<sup>(1)</sup> \_\_\_\_\_ PSI
- F. System's Working Pressure \_\_\_\_\_ PSI
- G. System's Test Pressure<sup>(2)</sup> \_\_\_\_\_ PSI
- H. Corrected Test Pressure & Testing Station<sup>(3)</sup> \_\_\_\_\_ PSI

Pressure Test<sup>(4)</sup>

- |    | Time         | Pressure Reading |
|----|--------------|------------------|
| I. | Start _____  |                  |
| J. | Finish _____ |                  |
|    | PASS _____   | FAIL _____       |

Leakage Test

- K. Test Pipe Diameter
- L. Test Pipe Length
- M. Allowable Leakage Rate \_\_\_\_\_ GPH
- N. Actual Leakage \_\_\_\_\_ Gallons
- O. Test Length \_\_\_\_\_ Hours

P. Actual Leakage Rate

PASS \_\_\_\_\_ FAIL

- (1)  $E = D \times 0.443 \text{ PSI}$
- (2)  $G = F \times 1.50$ , but not less than 150.0 PSI or not less than 200.0 PSI if fire line
- (3)  $H = G \ \& \ E$
- (4) Pressure Test duration minimum 3 hours  
Allowable pressure variation  $5 \pm \text{PSI}/2 \text{ hours}$

\*\* END OF SECTION \*\*



# Freezeless Commercial Wall Hydrants



Model 65

Model 67

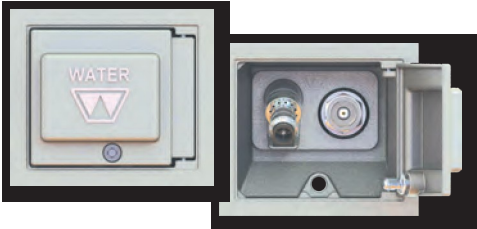

Model  
B65/B67  
Rectangular  
Box & Door

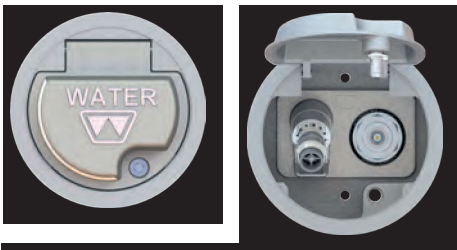

Model  
RB65/RB67  
Round  
Box & Door



Model  
MB65/MB67  
Composite Box  
Stainless Steel  
Door & Fascia



Model 68  
Undercover  
Wall Hydrant™  
in Stainless Steel  
Down Cover



Model HC65/HC67  
Hot & Cold



Model HCB65/HCB67



**Note:** The Model 70 does not share 65/67 series features. See page 2 for Model 70 specifications.

Woodford Model 65, 67 & 68 series wall hydrants are available as exposed or boxed wall mounted hydrants. Choose single check anti-siphon or dual check backflow protected models as required. Wall hydrants are designed to blend with modern architecture for installation on a wide range of commercial buildings.

- Automatic draining
- Hydrant fits one standard brick course
- Cast brass box models fit two standard brick course
- Wall thickness: 4" - 24" in 2" increments
- 3/4" male hose thread nozzle
- Cast brass round box models fit 6" diameter cored hole
- One piece valve plunger seated in brass valve body
- Copper tube casings
- No lead solder on all solder joints
- Hardened stainless steel stem
- Loose tee key operation
- 3/8" solid brass operating rod
- Chrome finish standard. Other finishes available.
- MAX PRESSURE; 125 p.s.i.
- MAX TEMPERATURE; 120° F

Scan For Specifications,  
Installation and  
Troubleshooting



*For information, please contact:*

# Freezeless Commercial Wall Hydrants Specifications



When ordering, specify model, Inlet and Wall Thickness.....Example B67C-12

MODEL	SPECIFICATIONS	INLET	FINISH
<b>67</b>	<ul style="list-style-type: none"> <li>Freezeless Wall Hydrant; UPC, cUPC Approved</li> <li>*ASSE 1052 Nidel® 50HA High Flow Double Check Backflow Preventer</li> </ul>	<b>C or P</b>	
<b>B67</b>	<ul style="list-style-type: none"> <li>67 Freezeless Wall Hydrant</li> <li>Brass Rectangular Box</li> </ul>	<b>C or P</b>	Std: Chrome Opt: Rough Brass (BR) Polished Brass (PB)
<b>RB6</b>	<ul style="list-style-type: none"> <li>67 Freezeless Wall Hydrant</li> <li>Brass Round Box</li> </ul>	<b>C or P</b>	
<b>HC6</b>	<ul style="list-style-type: none"> <li>67 Freezeless Wall Hydrant</li> <li>Single Control Hot &amp; Cold Mixer</li> </ul>	<b>3/4" FPT (2)</b>	
<b>HCB67</b>	<ul style="list-style-type: none"> <li>HC67 Freezeless Hot &amp; Cold Mixer Wall Hydrant</li> <li>Rectangular Brass Box &amp; Door</li> </ul>	<b>3/4" FPT (2)</b>	
<b>MB67</b>	<ul style="list-style-type: none"> <li>67 Freezeless Wall Hydrant</li> <li>Modular Composite Box, Heavy Gauge Stainless Steel Door &amp; Fascia</li> </ul>	<b>C or P</b>	Chrome (Hydrant)
<b>65</b> ASSE 1019-B	<ul style="list-style-type: none"> <li>Freezeless Wall Hydrant</li> <li>ASSE 1011 Nidel® 34HA Single Check Vacuum Breaker; CSA, UPC Approved</li> </ul>	<b>C or P</b>	
<b>B65</b> ASSE 1019-B	<ul style="list-style-type: none"> <li>65 Freezeless Wall Hydrant</li> <li>Rectangular Brass Box</li> </ul>	<b>C or P</b>	Std: Chrome Opt: Rough Brass (BR) Polished Brass (PB)
<b>RB65</b> ASSE 1019-B	<ul style="list-style-type: none"> <li>65 Freezeless Wall Hydrant</li> <li>Round Box - Chrome Only</li> </ul>	<b>C or P</b>	
<b>MB65</b> ASSE 1019-B	<ul style="list-style-type: none"> <li>65 Freezeless Wall Hydrant</li> <li>Modular Composite Box, Heavy Gauge Stainless Steel Door &amp; Fascia</li> </ul>	<b>C or P</b>	
<b>68</b> ASSE 1053	<ul style="list-style-type: none"> <li>68 Freezeless Undercover Wall Hydrant™</li> <li>Integral Stainless Steel flip-down head cover</li> <li>*ASSE 1052 Nidel® 50HA High Flow Double Check Backflow Preventer</li> </ul>	<b>C or P</b>	Std: Chrome Opt: Rough Brass (BR)
<b>C22</b>	<ul style="list-style-type: none"> <li>Freezeless Hot &amp; Cold Wall Faucet • **Patented PRV Pressure Relief Valve (both tubes)</li> <li>*ASSE 1052 Nidel® 50HA High Flow Double Check Backflow Preventer</li> </ul>	<b>C, CP, CP3, P, PX, PX3</b>	Chrome
<b>B22</b>	<ul style="list-style-type: none"> <li>C22 Freezeless Hot &amp; Cold Wall Faucet</li> <li>Rectangular Brass Box and Door</li> </ul>	<b>C, CP, CP3, P, PX, PX3</b>	Std: Chrome (CH) Opt: (BR) B22-BR
<b>21</b>	<ul style="list-style-type: none"> <li>Hose Nozzle - No Anti-Siphon Protection • Std: Polycarbonate Wheel Handle &amp; Tee Key</li> <li>Optional Metal Wheel Handle</li> </ul>	<b>P1/2, P3/4 C, CP</b>	
<b>24</b>	<ul style="list-style-type: none"> <li>ASSE 1011 Nidel® Model 34HF Anti-Siphon Vacuum Breaker; IAPMO® Listed</li> <li>Std: Polycarbonate Wheel Handle &amp; Tee Key • Optional Metal Wheel Handle</li> </ul>	<b>P1/2, P3/4 C, CP</b>	
<b>26</b>	<ul style="list-style-type: none"> <li>*ASSE 1052 Nidel® Model 50HF High Flow Double Check Backflow Preventer</li> <li>Std: Polycarbonate Wheel Handle &amp; Tee Key; Optional Metal Wheel Handle</li> </ul>	<b>P1/2, P3/4 C, CP</b>	Std: Chrome (CH) Opt: Rough Brass (BR) Polished Chrome (PC)
<b>B24</b>	<ul style="list-style-type: none"> <li>Model 24 with Brass Box &amp; Door; Tee Key Lock</li> </ul>	<b>P1/2, P3/4</b>	
<b>B26</b>	<ul style="list-style-type: none"> <li>Model 26 with Brass Box &amp; Door; Tee Key Lock</li> </ul>	<b>P1/2, P3/4</b>	
<b>70</b>	<ul style="list-style-type: none"> <li>3/4" Hose Nozzle - No Anti-Siphon Protection • Recessed Head</li> <li>1" galvanized steel pipe casing Permanent type brass valve body with hemispherical seating surface</li> </ul>	<b>C or P</b>	
<b>MB24-1/2</b> <b>MB24-3/4</b>	<ul style="list-style-type: none"> <li>Model 24 with Light weight Composite Box, Heavy Gauge Stainless Steel Door &amp; Fascia</li> <li>Tee Key Lock</li> </ul>	<b>P1/2, P3/4</b>	Chrome (CH)
<b>MB24-1/2-K</b> <b>MB24-3/4-K</b>	<ul style="list-style-type: none"> <li>Model 24 with Light weight Composite Box, Heavy Gauge Stainless Steel Door &amp; Fascia</li> <li>Key Cylinder Lock</li> </ul>	<b>P1/2, P3/4</b>	Chrome (CH)
<b>MB26-1/2</b> <b>MB26-3/4</b>	<ul style="list-style-type: none"> <li>Model 26 with Light weight Composite Box, Heavy Gauge Stainless Steel Door &amp; Fascia</li> <li>Tee Key Lock</li> </ul>	<b>P1/2, P3/4</b>	Chrome (CH)
<b>MB26-1/2-K</b> <b>MB26-3/4-K</b>	<ul style="list-style-type: none"> <li>Model 26 with Light weight Composite Box, Heavy Gauge Stainless Steel Door &amp; Fascia</li> <li>Key Cylinder Lock</li> </ul>	<b>P1/2, P3/4</b>	Chrome (CH)
<b>MB221</b>	<ul style="list-style-type: none"> <li>Hose Nozzle - No Anti-Siphon Protection • Integral Water Supply Stop in Head</li> <li>Light weight Composite Box, Heavy Gauge Stainless Steel Door &amp; Fascia</li> <li>Tee Key Lock; Optional Cylinder Lock (K)</li> </ul>	<b>1/2-14 FPT</b>	Brass Components
<b>MB224</b>	<ul style="list-style-type: none"> <li>ASSE 1011 Nidel® Model 34HF Anti-Siphon Vacuum Breaker; IAPMO® Listed</li> </ul>	<b>1/2-14 FPT</b>	Brass Components
<b>MB226</b>	<ul style="list-style-type: none"> <li>*ASSE 1052 Nidel® Model 50HF High Flow Double Check Backflow Preventer</li> </ul>	<b>1/2-14 FPT</b>	Brass Components

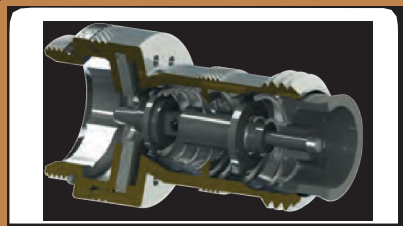

## \*NIDEL® Model 50 Backfl Preventer

The patented NIDEL® Model 50 high flow double check backflow preventer is standard equipment on specified commercial wall hydrant models. It is intended for irrigation and outdoor watering and is designed to protect hose connections from backflow contamination in freezing and non-freezing conditions. The Model 50 automatically drains when the hose is removed and unlike single check vacuum breakers can be field tested for reliability.

- ASSE 1052 Approved
- High Flow Rate
- Field Testable (see instruction sheet)
- Drains automatically when hose is removed
- Two independent check valves
- No spray back

# Freezeless Commercial Wall Hydrants Parts List



MODEL 65/67 & HC65/HC67		
ITEM	PART#	DESCRIPTION
1	50009	Tee Key
	50010	Long Tee Key (Box Models)
	50264	Head Nut - chrome
2	50265	Head Nut - brass
	50583	I.D. Ring
3	50583	I.D. Ring
4	50252	Stem Washer
5	55062	Stem Screw
6	50251	"C" Washer
7	51014	Yoke Nut
8	50250	Plunger
9	50HA-CH	NIDEL® 50HA Backflow Preventer - chrome
	50HA-BR	NIDEL® 50HA Backflow Preventer - brass
10	34HA-CH	NIDEL® 34HA Vacuum Breaker - chrome
	34HA-BR	NIDEL® 34HA Vacuum Breaker - brass
11	50559	Handle Screw
1	50547	Handle - brass
	50548	Handle - chrome
13	50545	Locking Nut
	50543	Face Plate - brass
1	50544	Face Plate - chrome
15	361XX	HC67 Casing Assembly (Includes Items 16 & Call for assistance)
16	51093	O-Ring AS-023
17	50529	Support Washer
18	51092	O-Ring AS-110
19	5508X	Rod Assembly - Call for assistance
20	5053X	Casing Shield - Call for assistance
21	50500	Mixer Body
22	50502	Gasket (2 required)
23	55079	Shuttle Housing Assembly (2 required)
24	51050	Tamper Proof Screws (6 required)
25	50542	Wall Plate - chrome
26	55063	Wall Clamp Assembly
27	67BX	Box/Door Assembly - Chrome
28	51120	E-Ring
29	51117	Door Lock Screw - Chrome
	51116	Door Lock Screw - Brass
30	RB67BX	Round Box/Door Assembly - Chrome
31	MB65BX	Modular Box/Door Assembly - Chrome
32	50041	Headless Shoulder Bolt (2)
33	30150	Cam Lock Cam Screw
34	30143	Cam Lock
35	30155	Cam Lock Hex Nut
36	50280	Stainless Steel Head Cover
37	30140	Tee Key Lock Well
38	30156	Tee Key Lock Disc Spring
39	30139	Tee Key Lock
553XX		HC Operating Rod Assemblies (See chart for Overall Length)
RK-65		Chrome Repair Kit (Includes Items 1-8)
RK-HC		HC/HCB Repair Kit (Includes Items 16-18,22,23)
RK-38		Cover Repair Kit (Includes Items 32-39)

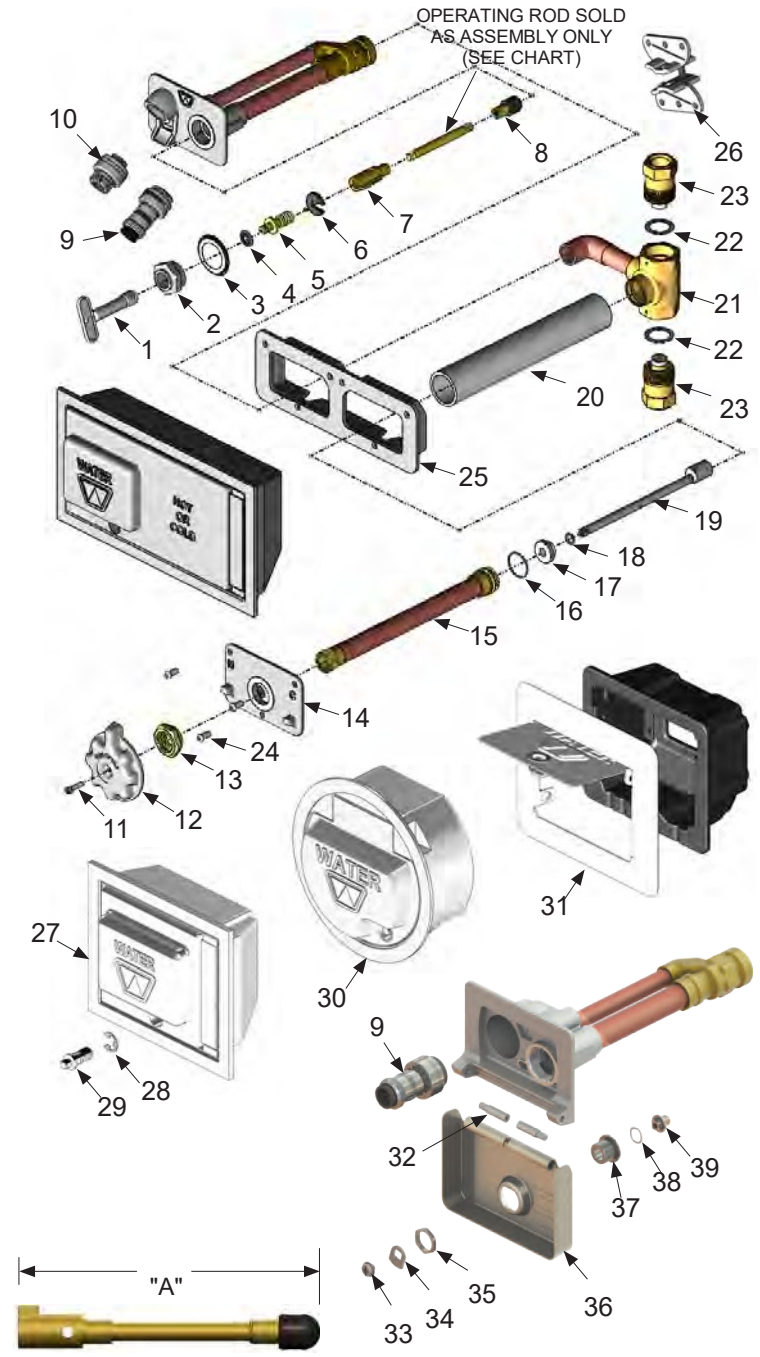

Wall Thickness (Inches)	Overall Length (Inches)	Part No.
67 B67/RB67		
CC CC	3 ½	55401
N/A 4	4 ½	55402
4 6	6 ½	55404
6 8	8 ½	55406
8 10	10 ½	55408
10 12	12 ½	55410
12 14	14 ½	55412
14 16	16 ½	55414
16 18	18 ½	55416
18 20	20 ½	55418
20 22	22 ½	55420
22 24	24 ½	55422
24 N/A	26 ½	55424

**INLET - Model 65 & 67 Series**  
4 3/8" Min. Length In Heated Area



# Freezeless Commercial Wall Hydrants Rough-In Dimensions

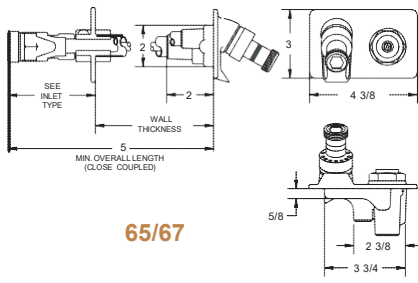

**65/67**

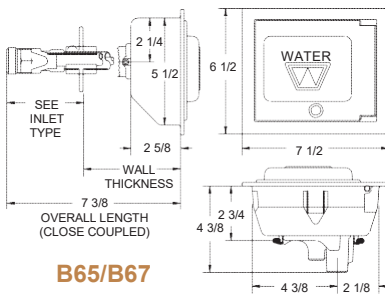

**B65/B67**

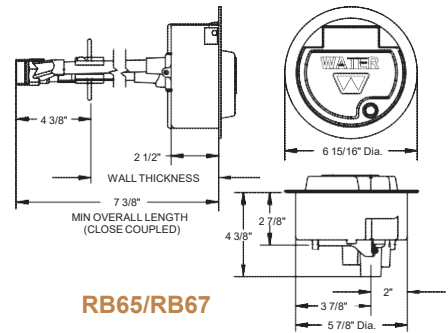

**RB65/RB67**

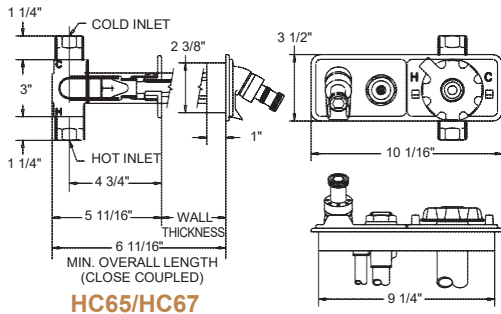

**HC65/HC67**

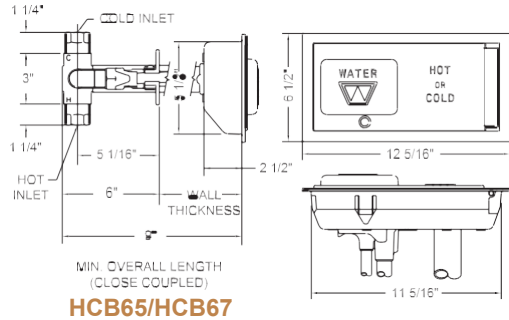

**HCB65/HCB67**

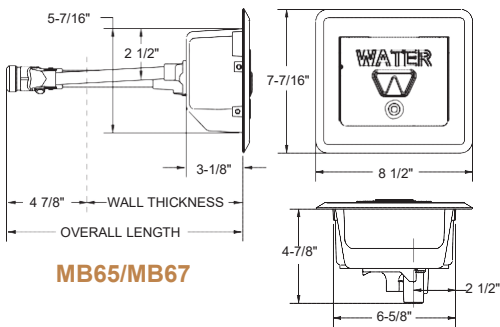

**MB65/MB67**

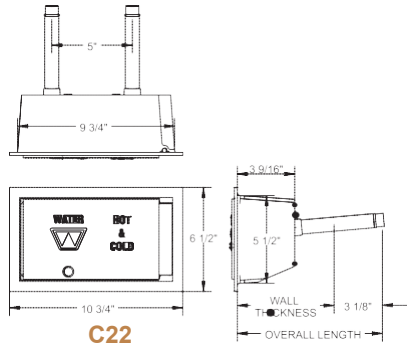

**C22**

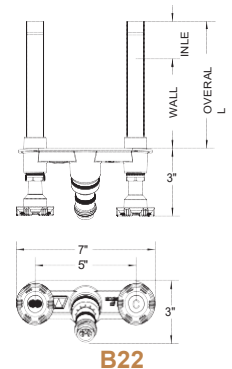

**B22**

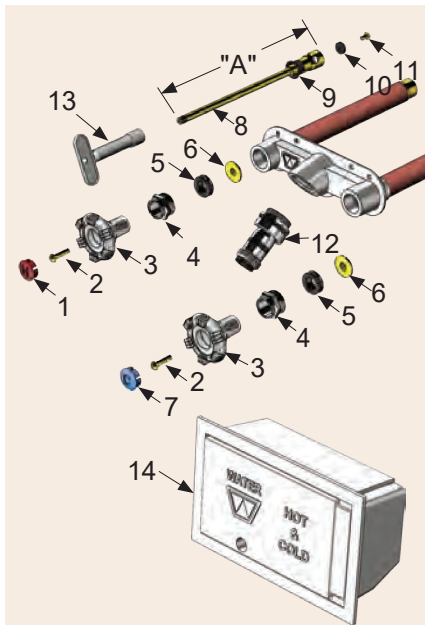

**MODEL C22 / B22 PARTS**

ITEM	PART#	DESCRIPTION
1	30463	Plug Button-H-Red (for plastic handle)
	30566	Plug Button-H-Red (for metal handle)
2	30002	Handle Screw (2)
3	30542	Wheel Handle - Clear (2)
4	30096	Wheel Handle - Metal (2) <i>Optional</i>
	30539	Packing Nut - Chrome (2)
5	30059	Packing Nut - Brass (2) <i>Optional</i>
	30560	EPDM Packing (2)
6	30006	Packing Support Washer
7	30462	Plug Button-C-Blue (for plastic handle)
	30565	Plug Button-C-Blue (for metal handle)
8	RK-PRV	PRV Valve Stem Assembly (See chart)
9	30459	Check Valve (2)
10	30008	Valve Seat Rubber (2)
11	30804	Retainer Screw (2)
12	50HA-CH	50HA Backflow Preventer - Chrome
	50HA-BR	50HA Backflow Preventer - Brass
13	50012	Tee Key
14	22BX	Box/Door Assembly - Chrome

**Item 8 - PRV Operating Rod Assy. "A"**

Wall Thickness (Inches)	Overall Length (Inches)	PRV Model
CC (1 3/4)		N/A
4	5 7/8	RK-PRV-4
6	7 7/8	RK-PRV-6
8	9 7/8	RK-PRV-8
10	11 7/8	RK-PRV-10
12	13 7/8	RK-PRV-12
14	15 7/8	RK-PRV-14
16	17 7/8	RK-PRV-16
18	19 7/8	RK-PRV-18
20	21 7/8	RK-PRV-20
22	23 7/8	RK-PRV-22
24	25 7/8	RK-PRV-24

RK-22MH  
Brass Parts  
Repair Kit (Metal Handles) Includes  
1 ea: Item 1a, 7a,  
2 ea: Items 2, 3a, 4a, 5, 6, 9, 10, 11



# Freezeless Commercial Wall Hydrants Lite Duty Commercial



## Hot & Cold Wall Faucet



Model C22

Model B22

- Chrome plate standard
- Model 50HA Double Check Backflow Preventer
- Clear, Round Handles - Standard (Tee Key optional)
- C22 Exposed Head Model 4" - 24" Wall Thickness
- B22 Rectangular Box Model 6" - 24" Wall Thickness
- (6) Inlet Options (See page 2 for details)
- 3/4" male hose thread nozzle
- Stainless steel seat - eliminates wire draw
- EPDM Packing
- Full circle operating threads on valve body and retainer
- No lead solder on all solder joints
- Standard "O" size beveled seat washer
- Adjustable packing nut
- Chrome plated red brass head casting
- 5/16" solid brass valve stem
- Check valve on valve stem
- MAX PRESSURE; 125 p.s.i.
- MAX TEMPERATURE; 120° F

## Mild Climate Area Wall Faucets

Choose a close connection Mild Climate wall faucet for areas where freezing conditions are not likely to occur.





- Exposed chrome plate brass head models are available with single check vacuum breaker or double check backflow preventer
- 3 security box models are available for the Model 24 or 26
- Select chrome plated brass, anodized aluminum or modular box and stainless steel door and fascia
- See page 2 for model specifications
- Not intended for potable water applications.



B24/B26

MB24/MB26

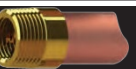
Dia. X Min. Length In Heated Area

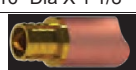
<b>C</b>		COMBINATION Copper Sweat Fitting 1/2" K, L or M Inside 3/4" M Only Outside
	15/16" Dia X 15/16"	
<b>CP</b>		COMBINATION 1/2" Male Pipe Thread 1/2" Female Sweat
	15/16" Dia X 1 1/4"	
<b>CP3</b>		COMBINATION 3/4" Male Pipe Thread 3/4" Female Sweat
	1 1/16" Dia X 1 3/8"	
<b>P</b>		COMBINATION 1/2" Female Pipe Thread 3/4" Male Pipe Thread
	1 1/16" Dia X 1 3/8"	
<b>PX</b>		1/2" PEX Tube Fitting
	15/16" Dia X 1 1/8"	
<b>PX3</b>		3/4" PEX Tube Fitting
	15/16" Dia X 1 1/8"	

## Integral Water Supply Stop MB221-MB224-MB226



- Designed to eliminate the need for entering a building in order to shut off water supply for servicing the hydrant in mild climate areas.
- A convenient integral water supply stop, with screwdriver slot, is located at the faucet head.
- The MB220 series includes the hydrant, composite box and lockable stainless steel door and fascia.
- See page 2 for model specifications

## \*\*PRV Pressure Relief Valve

U.S. Patent #6,805,154 B1

### Standard on Models C22 & B22

The patented, resetting PRV prevents the faucet tube from bursting in freezing conditions even if a hose is unintentionally left on.

The PRV protects up to 125 psi of backpressure and therefore does not require an add-on vacuum breaker.

**Piston activates at approx. 350 psi**

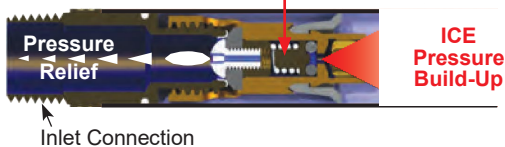

Inlet Connection

## SL-65 Stem Lock

Fits Models 65 & 67 Series Products.



Replace the standard packing nut with the furnished brass locking nut and snap on the lock. 2 keys are included.

A Tee key is included for operating the faucet when lock is removed.



# Freezeless Commercial Wall Hydrants Information



## NOTICE

- All hydrants are intended For Irrigation and Outdoor Watering.
- All hydrants are not recommended for continuous use.
- All specifications are subject to change without notice.

Visit our website for Patent Information, Individual Spec. Sheets,  
Installation and Troubleshooting Instructions  
[www.woodfordmfg.com](http://www.woodfordmfg.com) or call 1-800-621-6032

## Limited 5 Year Warranty

*All commercial hydrants shown in this brochure are sold with a limited warranty for five years against defects in material and workmanship. We will replace or issue credit (at our option) for defective goods that are returned for inspection and found to be defective within five years of purchase from Woodford.*

### SHIPPING WEIGHTS

Wall Thickness (inches)*	4	6	8	10	12	14	16	18	20	22	24
Model 65 & 67 (Lbs. Each)**	4.4	4.8	5.2	5.6	6	6.4	6.8	7.2	7.6	8	8.4

\*Add 3/8" for all box hydrants

\*\*Add 7.0 Lbs for (B) brass box models

\*\*Add 2.5 Lbs for (MB) modular box models

\*\*Add 2.5 Lbs for all (AL) aluminum box models

Wall Thickness (inches)*	4	6	8	10	12	14	16	18	20	22	24
HC65 & HC67 (Lbs. Each)**	11.5	12.2	12.9	13.7	14.3	15.1	15.8	16.5	17.3	18.1	18.9

\*Add 3/8" for all box hydrants

\*\*Add 11.7 Lbs for (B) brass box models

Wall Thickness (inches)*	4	6	8	10	12	14	16	18	20	22	24
C22 (Lbs. Each)**	3.1	3.3	3.5	3.8	3.9	4.2	4.6	4.8	5	5.2	5.4

Add 14.7 Lbs. for B22 brass box models

**Cross-Over Models**  
Also listed on separate  
Mild Climate products brochure



MB24-MB26 Series



Woodford Manufacturing Company  
2121 Waynoka Road  
Colorado Springs, CO 80915 USA  
800-621-6032  
800-765-4115 (Fax)  
sales@woodfordmfg.com  
www.woodfordmfg.com

© Woodford Mfg. Co. 2013  
Printed in the U.S.A.

**SECTION 120270  
LAB FAUCETS**

**PART 1 – GENERAL**

Please view the following link for lab faucet specifications:

<http://www.airdelights.com/BL-5700-08>

**SECTION 120280**  
**EYE WASH**

PART 1 – GENERAL

Please view the following link for eye wash specifications:

<http://www.gesafety.com/downloads/G1101.pdf>

### PRODUCT SPECIFICATIONS

Halsey Taylor HydroBoost® Bottle Filling Station & Single ADA Cooler, Non-Filtered 8 GPH Stainless Steel. Chilling Capacity of 8.0 GPH (gallons per hour) of 50° F drinking water, based on 80° F inlet water and 90° F ambient, per ASHRAE 18 testing. Features shall include Mechanically-Activated, Sanitary Sensor Activated, Green Counter™, Laminar Flow, Antimicrobial, Real Drain. Furnished with Double Bubblers™. Electronic Bottle Filler Sensor With Mechanical Front And Side Bubbler Pushbar activation. Product shall be Wall Mount (On-Wall), for Indoor applications, serving 1 station(s). Unit shall be certified to UL 399 and CAN/CSA C22.2 No. 120. Unit shall be lead-free design which is certified to NSF/ANSI 61 & 372 (lead free) and meets Federal and State low-lead requirements.



<b>Special Features:</b>	Mechanically-Activated, Sanitary Sensor Activated, Green Counter™, Laminar Flow, Antimicrobial, Real Drain
<b>Finish:</b>	Stainless Steel
<b>Power:</b>	115V/60Hz
<b>Bubbler Style:</b>	Double Bubbler™
<b>Activation by:</b>	Electronic Bottle Filler Sensor With Mechanical Front And Side Bubbler Pushbar
<b>Mounting Type:</b>	Wall Mount (On-Wall)
<b>Chilling Option*:</b>	8.0 GPH
<b>Full Load Amps</b>	6
<b>Rated Watts:</b>	370
<b>Dimensions (L x W x H):</b>	17-7/8" x 18-1/2" x 39-3/4"
<b>Approx. Shipping Weight:</b>	89 lbs.
<b>Installation Location:</b>	Indoor
<b>No. of Stations Served:</b>	1
*Based on 80° F inlet water & 90° F ambient air temp for 50° F chilled drinking water.	

- Mechanically-Activated bubbler continues to supply water in event of service disruptions.
- Touchless, sensor-activation, designed for easy use.
- Green Counter: Informs user of number of 20 oz. plastic water bottles saved from waste.
- Laminar flow provides clean fill with minimal splash.
- Silver Ion Antimicrobial protection on key plastic components to inhibit the growth of mold and mildew.
- Real Drain System eliminates standing water.
- Exclusive Double Bubbler which projects two separate streams that converge to form a fuller, more satisfying drink.

#### COOLING SYSTEM

- Compressor: Hermetically-sealed, reciprocating type, single phase. Sealed-in lifetime lubrication.

PART: \_\_\_\_\_ QTY: \_\_\_\_\_

PROJECT: \_\_\_\_\_

CONTACT: \_\_\_\_\_

DATE: \_\_\_\_\_

NOTES: \_\_\_\_\_

APPROVAL: \_\_\_\_\_

*In keeping with our policy of continuing product improvement, Halsey Taylor reserves the right to change product specifications without notice. Please visit [Halseytaylor.com](http://Halseytaylor.com) for the most current version of Halsey Taylor product specification sheets. This specification describes a Halsey Taylor product with design, quality, and functional benefits to the user. When making a comparison of other producers' offerings, be certain these features are not overlooked.*

#### AMERICAN PRIDE. A LIFETIME TRADITION.

Like your family, the Elkay family has values and traditions that endure. For almost a century, Elkay has been a family-owned and operated company, providing thousands of jobs that support our families and communities.



**Included with Product:** Water Cooler (8240081683-HTHB),  
Bottle Filler (HTHB-HAC-NF)

#### PRODUCT COMPLIANCE

ADA & ICC A117.1

Buy American Act

CAN/CSA C22.2 No. 120

GreenSpec®

NSF/ANSI 61 & 372 (lead free)

UL 399



Complies with ADA & ICC A117.1 accessibility requirements when installed according to the requirements outlined in these standards. Installation may require additional components and/or construction features to be fully compliant. Consult the local Authority Having Jurisdiction if necessary.

[Installation Instructions \(PDF\)](#)

**5 Year Limited Warranty** on the refrigeration system of the unit. Electrical components and water system are warranted for 12 months from date of installation. **Warranty pertains to drinking water applications only. Non-drinking water applications are not covered under warranty.**

[Warranty \(PDF\)](#)

#### OPTIONAL ACCESSORIES

HWF3000 - WaterSentry Plus Filter Kit (Bottle Fillers)
MLP100 - Accessory - In Wall Carrier (Single)
98324C - Accessory - Cane Apron for HAC, HVR, EMABF & VRC Models (Stainless)

- Condenser: Fan cooled, copper tube with aluminum fins. Fan motor is permanently lubricated.
- Cooling Unit: Combination tube-tank type. Continuous copper tubing with is fully insulated with EPS foam that meets UL requirements for self-extinguishing material.
- Refrigerant Control: Refrigerant R-134a is controlled by accurately calibrated capillary tube.
- Temperature Control: Easily accessible enclosed adjustable thermostat is factory preset. Requires no adjustment other than for altitude requirements.

*In keeping with our policy of continuing product improvement, Halsey Taylor reserves the right to change product specifications without notice. Please visit [Halseytaylor.com](http://Halseytaylor.com) for the most current version of Halsey Taylor product specification sheets. This specification describes a Halsey Taylor product with design, quality, and functional benefits to the user. When making a comparison of other producers' offerings, be certain these features are not overlooked.*

**IMPORTANT!**  
**INSTALLER PLEASE NOTE :**

This water cooler has been designed and built to provide water to the user which has not been altered by materials in the cooler waterways. The grounding of electrical equipment such as telephone, computer, etc. to water lines is a common procedure. The grounding may be in the building but may also occur away from the building. This grounding can cause electrical feedback into a water cooler creating an electrolysis which creates a metallic taste or causes an increase in the metal content of the water. This condition is avoidable by installing the cooler using the proper materials as shown below.

**NOTICE**

This water cooler must be connected to the water supply using a dielectric coupling. The cooler is furnished with a non-metallic strainer which meets this requirement. The drain trap which is provided by the installer should also be plastic to completely isolate the cooler from the building plumbing system. Bottle filler unit on bracket attached to wall by 6 holes (as shown). Water and electrical will connect through pre-punched hole in basin.

**OPERATION OF QUICK CONNECT FITTINGS**

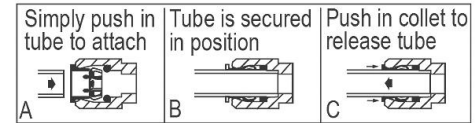

Pushing tube in before pulling it out helps to release tube

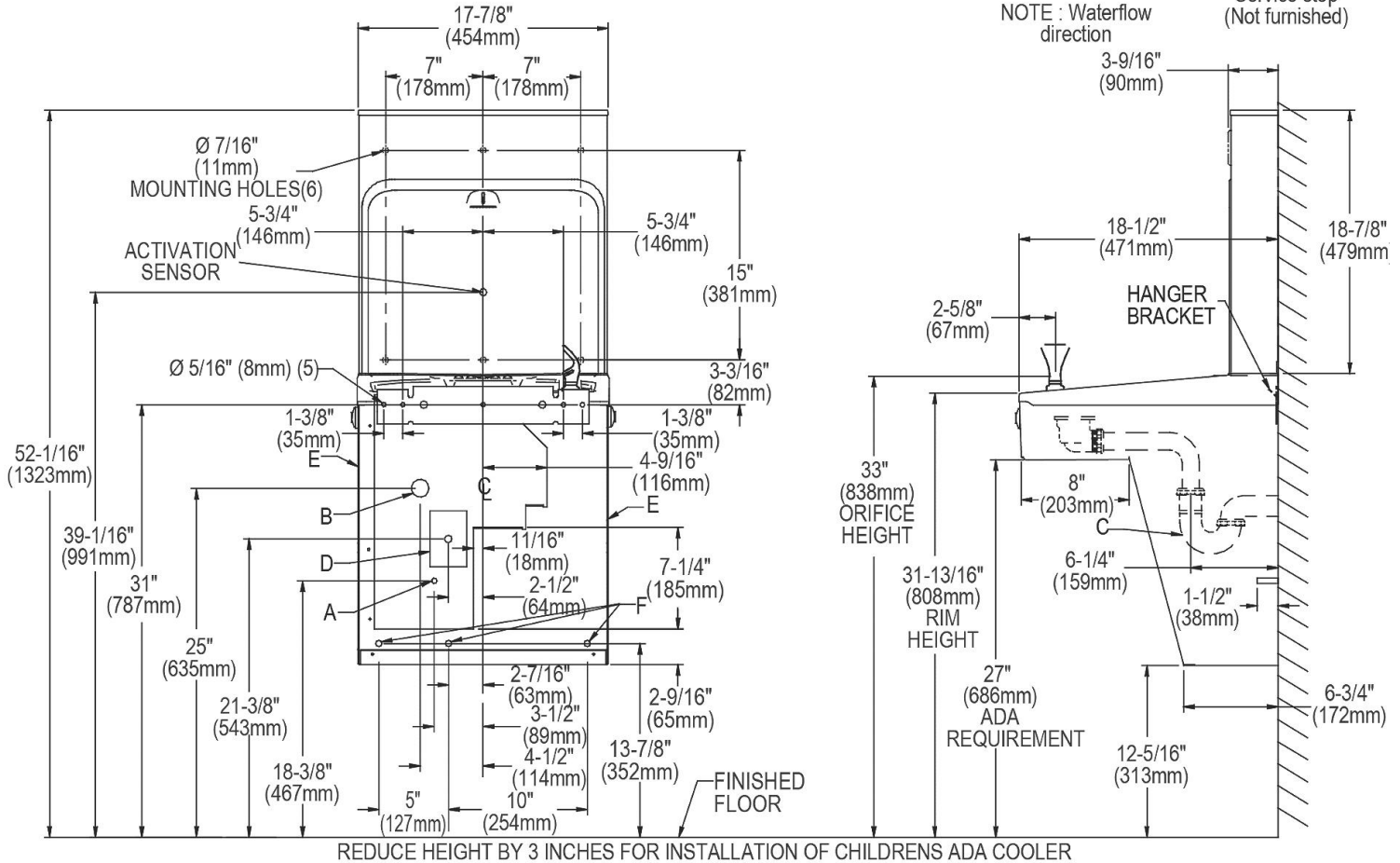
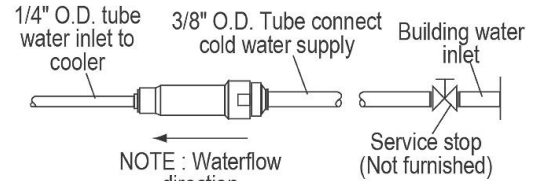

**LEGEND:**

- A = Recommended Water Supply location. Shut-off Valve (not furnished) to accept 3/8" O.D. unplated copper tube. Up to 3" (76mm) maximum out from wall.
- B = Recommended Waste Outlet location. To accommodate 1-1/4" nominal drain. Drain stub 2" (51mm) out from wall.
- C = 1-1/4" Trap (not furnished).
- D = Electrical Supply (3) Wire Recessed Box Duplex Outlet.
- E = Insure proper ventilation by maintaining 6" (152mm) minimum clearance from cabinet louvers to wall.
- F = 7/16" (11mm) Bolt Holes for fastening to wall.

NOTE: New Installations Must Use Ground Fault Circuit Interrupter (GFCI). It is highly recommended that the circuit be dedicated and the load protection be sized for 20 amps.

In keeping with our policy of continuing product improvement, Halsey Taylor reserves the right to change product specifications without notice. Please visit [Halseytaylor.com](http://Halseytaylor.com) for the most current version of Halsey Taylor product specification sheets. This specification describes a Halsey Taylor product with design, quality, and functional benefits to the user. When making a comparison of other producers' offerings, be certain these features are not overlooked.

## SECTION 140010

### CHEMICAL WATER TREATMENT

#### PART 1 - GENERAL

##### 1.1 SECTION INCLUDES

- A. Cleaning of closed loop piping systems
- B. Chemical feeder equipment
- C. Chemical treatment
- D. Filter/feeder

##### 1.2 REFERENCES

- A. NFPA 70 - National electrical code.

##### 1.3 SUBMITTALS

- A. Submit in accordance with provisions of section 230010.
- B. Shop drawings: Indicate system schematic, equipment locations, and controls schematics, electrical characteristics and connection requirements.
- C. Product data: Provide chemical treatment materials, chemicals, and equipment including electrical characteristics and connection requirements.

##### 1.4 REGULATORY REQUIREMENTS

- A. Conform to applicable code for addition of non-potable chemicals to building mechanical systems, and for to public sewage systems.
- B. Products requiring electrical connection: Listed and classified by UL as suitable for the purpose specified and indicated.

##### 1.5 MAINTENANCE SERVICE

- A. Furnish service and maintenance of treatment systems for one year from date of substantial completion.
- B. Provide quarterly technical service visits to perform field inspections and make water analysis on site. Detail findings in writing on proper practices, chemical treating requirements, and corrective actions needed. Submit two copies of field service report after each visit.

##### 1.6 PROCEDURE

- A. If this system is to be tied into an existing system than some form of lock-out valve should be utilized until the new system is proper commissioned before being allowed to be tied into the existing system. This will prevent containments from entering the existing system.

#### PART 2 - PRODUCTS

##### 2.1 MANUFACTURER

- A. Guardian CSC, Rick Bahr, (717) 848-2540- no substitutions



## 2.2 EQUIPMENT

- A. Five gallon filter/feeder with legs, model Vector FA-1000AL VF-1000HT250
- B. One case of twelve filter cartridges shall be provided: 3 ten micron, 3 five micron, and 6 one micron filters.

## 2.3 SYSTEM PREPARATION

- A. Water flush applies to the following systems:
  - 1. Closed Loop Water: Dump and refilled the closed loop system to remove existing raw contaminants and suspended solids. This procedure should be done twice.
- C. Refill the system with water and allow for 10 percent by volume of pre-cleaner Formula 6960 for the removal of scale, glycol oils and other extraneous materials. Add the required amount of cleaner and circulate for 24 hour.
- E. Flush the system after the required circulation period as quickly as possible, this will prevent settling of foulants. Run circulating pumps and flush with clean water until the discharge water is clear and the pH is within 0.5 of the incoming makeup water, and the conductivity of the loop water is within 25 micro ohms of the make-up water conductivity. Once the system water is clear, remove, clean and replace all strainers.
- F. Immediately add Formula 6204 to obtain a residual of 1000-15.300 ppm. Allow time for the inhibitor to circulate and retest to ensure that this level of inhibitor has been achieved within the system.
- H. Service on a quarterly basis making necessary adjustments to maintain the residual with the recommended operational control ranges of 600 to 1200 ppm. as Nitrite.

## PART 3 - EXECUTION

### 3.1 INSTALLATION

- A. Install in accordance with manufacturer's instructions.
- B. Provide one filter/feeder on each system. Filter feeder shall be plumbed across the common headers for the discharge and return lines.

### 3.2 WATER TREATMENT PROGRAM

- A. The Water Treatment Company shall provide:
  - 1. Installation and system start-up procedure recommendations
  - 2. Pre-operation system cleanout procedure supervision
  - 3. Training of operating personnel on proper feeding and control techniques
  - 4. Quarterly field service and consultation meetings
  - 5. Any necessary log sheets and record forms
  - 6. Any required laboratory and technical assistance
- B. All services shall be provided by a qualified, full-time representative of the Water Treatment Company.

END OF SECTION 140010